

KA3021D

4-Channel Motor Driver

Features

- 3-channel Balanced TransformerLess(BTL) driver
- 1-channel forward-reverse control DC motor driver
- Built-in thermal shutdown circuit
- Built-in mute circuit
- Operating supply voltage: 4.5V ~ 13.2V
- Corresponds to 3.3V or 5V DSP

Description

The KA3021D is a monolithic IC, suitable for a 1-ch (Forward.reverse) control DC motor driver and a 3-ch motor driver which drives the focus actuator, tracking actuator, and sled motor of a CD-media system.



Typical Applications

- Compact disk ROM (CD-ROM)
- Compact disk RW (CD-RW)
- Digital video disk ROM (DVD-ROM)
- Digital video disk RAM (DVD-RAM)
- Digital video disk Player (DVDP)
- Other compact disk media

Ordering Information

Device	Package	Operating Temp.
KA3021D	28-SSOPH-375	-35°C ~ +85°C
KA3021DTF	28-SSOPH-375	-35°C ~ +85°C

Pin Assignments

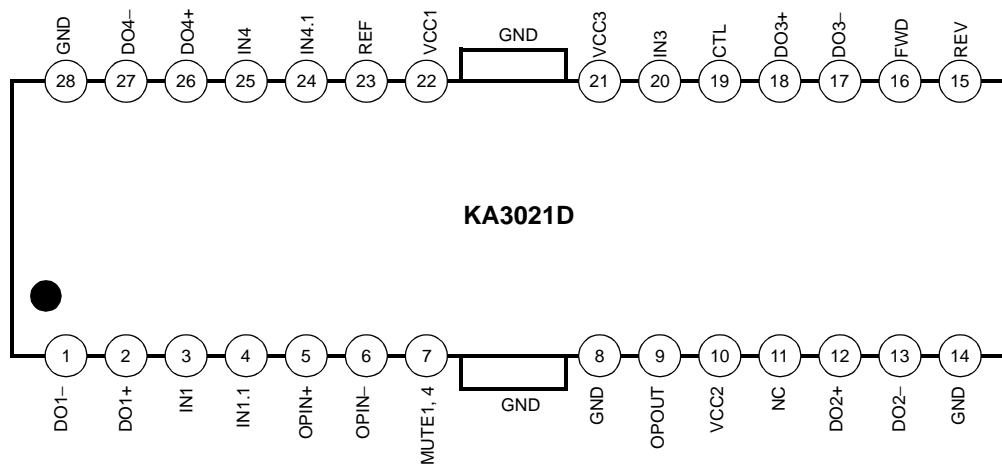

Pin Definitions

Pin Number	Pin Name	I/O	Pin Function Description
1	DO1-	O	Drive1 output (-)
2	DO1+	O	Drive1 output (+)
3	IN1	I	Drive1 input
4	IN1.1	I	Drive1 input gain adjust
5	OPIN+	I	Op-amp input (+)
6	OPIN-	I	Op-amp input (-)
7	MUTE1, 4	I	CH1, 4 mute
8	GND	-	Ground
9	OPOUT	O	Op-amp output
10	VCC2	I	Power supply for CH2 and signal
11	NC	-	No connection
12	DO2+	O	Drive2 output (+)
13	DO2-	O	Drive2 output (-)
14	GND	-	Ground
15	REV	I	CH2 reverse
16	FWD	I	CH2 forward
17	DO3-	O	Drive3 output (-)
18	DO3+	O	Drive3 output (+)
19	CTL	I	CH2 motor speed control
20	IN3	I	Ch3 input
21	VCC3	I	Power supply for CH3
22	VCC1	I	Power supply for CH1,4
23	REF	I	Bias voltage input
24	IN4.1	I	Drive4 input gain adjust
25	IN4	I	Drive4 input
26	DO4+	O	Drive4 output (+)
27	DO4-	O	Drive4 output (-)
28	GND	-	Ground

Internal Block Diagram

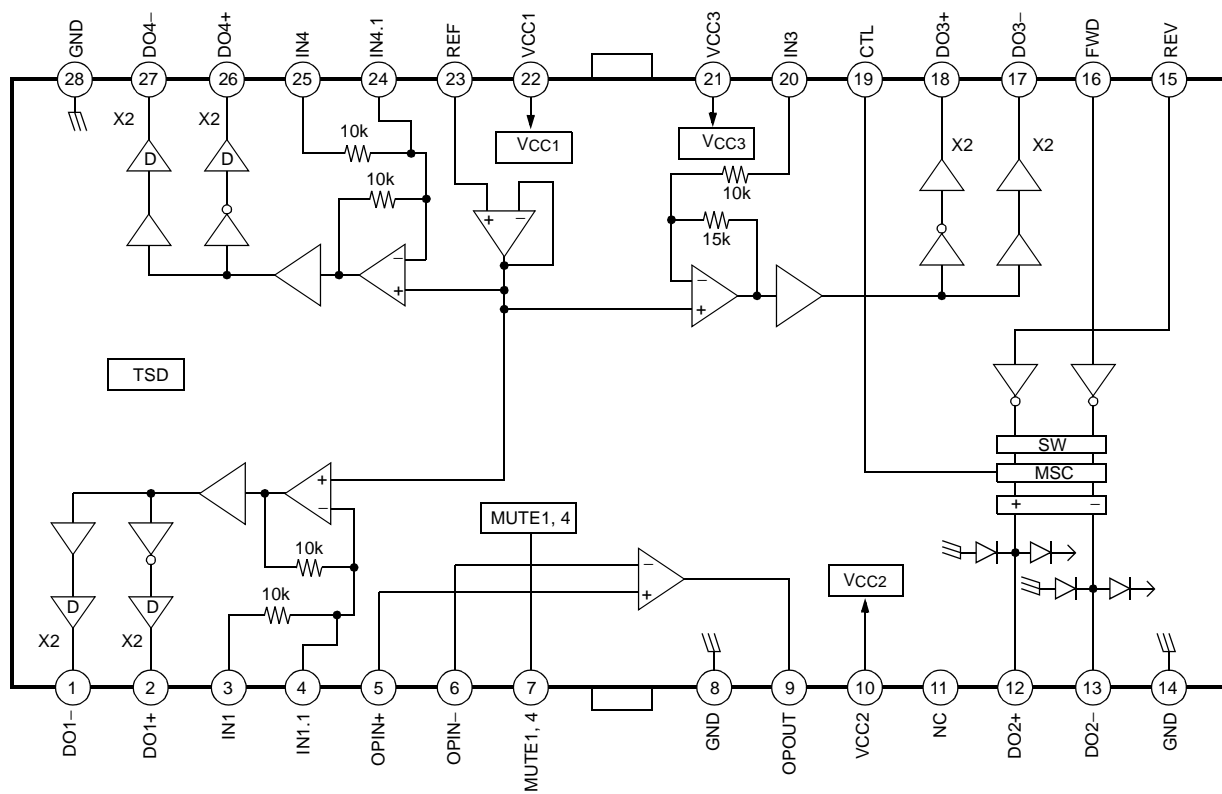

Equivalent Circuits

Mute input	Power output
Signal reference input	loading control input
Loading logic input	

Absolute Maximum Ratings (Ta = 25°C)

Parameter	Symbol	Value	Unit
Maximum supply voltage	V _{CCmax}	18	V
Power dissipation	P _D	1.7 ^{note}	W
Operating temperature range	T _{OPR}	-35 ~ +85	°C
Storage temperature range	T _{STG}	-55 ~ +150	°C

NOTE:

1. When mounted on a 50mm × 50mm × 1mm PCB (Phenolic resin material).
2. Power dissipation reduces 13.6mW / °C for using above Ta = 25°C
3. Do not exceed P_D and SOA (Safe operating area).

Power Dissipation Curve

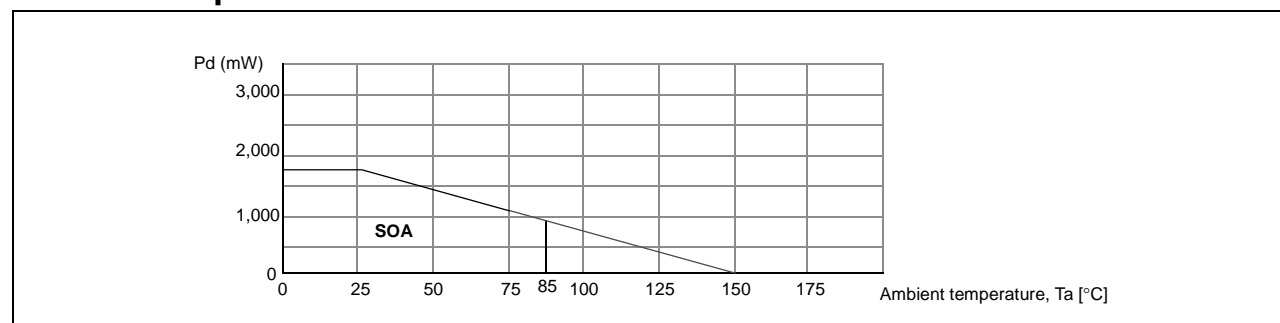

Recommended Operating Conditions (Ta = 25°C)

Parameter	Symbol	Min	Typ	Max	Unit
Supply voltage	V _{CC}	4.5	-	13.2	V

Electrical Characteristics

(Unless otherwise specified, $T_a=25^{\circ}\text{C}$, $V_{CC1}=V_{CC3}=5\text{V}$, $V_{CC2}=12\text{V}$)

Parameter	Symbol	Conditions	Min.	Typ.	Max.	Units
Quiescent current	I_{CC}	$V_{IN}=0\text{V}$	-	6	15	mA
Mute on current	I_{MUTE}	Mute pin=GND	-	4.5	8	mA
Mute on voltage	V_{Mon}	-	2.0	-	-	V
Mute off voltage	V_{Moff}	-	-	-	0.5	V
DRIVE CIRCUIT						
Output offset voltage	V_{OO}	$V_{IN}=2.5\text{V}$	-40	-	+40	mV
Maximum output voltage1 (High level)	V_{OM1}	$V_{CC}=8\text{V}$, $R_L=8\Omega$ (CH1,3,4)	5	6.0	-	V
Maximum output voltage2 (Low level)	V_{OM2}	$V_{CC}=8\text{V}$, $R_L=8\Omega$ (CH1,3,4)	-	-6.0	-5	V
Closed loop voltage gain1	G_{VC1}	$f=1\text{kHz}$, $V_{IN}=0.1\text{V}_{RMS}$ (CH1,4)	9.5	11.5	13.5	dB
Closed loop voltage gain2	G_{VC2}	$f=1\text{kHz}$, $V_{IN}=0.1\text{V}_{RMS}$ (CH3)	13.0	15.0	17.5	dB
Ripple rejection ratio	RR	$V_{IN}=0.1\text{V}_{RMS}$, $f=120\text{Hz}$	-	60	-	dB
Slew rate	SR	$V_O=2\text{V}_{p-p}$, $f=120\text{kHz}$	-	0.8	-	V / μs
TRAY DRIVE CIRCUIT ($V_{CC2}=V_{CC3}=8\text{V}$, $R_L=45\Omega$)						
Input high level voltage	V_{IH}	-	2	-	-	V
Input low level voltage	V_{IL}	-	-	-	0.5	V
Output voltage1	V_{O1}	$V_{CC}=8\text{V}$, $V_{CTL}=6.5\text{V}$	5.2	6	6.8	V
Output voltage2	V_{O2}	$V_{CC}=13\text{V}$, $V_{CTL}=4.5\text{V}$	7.5	8.5	9.5	V
Output load regulation	ΔV_{RL}	-	-	300	700	mV
Output offset voltage1	V_{OO1}	$V_{IN}=5\text{V}$	-40	-	+40	mV
Output offset voltage2	V_{OO2}	$V_{IN}=5\text{V}$	-40	-	+40	mV
GENERAL OF AMP CIRCUIT						
Input offset voltage	V_{OFOP}	-	-20	-	+20	mV
Input bias current	I_{BOP}	-	-	-	300	nA
High level output voltage	V_{OHOP}	$V_{CC}=5\text{V}$, $R_L=1\text{k}\Omega$	3	4	-	V
Low level output voltage	V_{OLOP}	$V_{CC}=5\text{V}$, $R_L=1\text{k}\Omega$	0.7	1	1.3	V
Output sink current	I_{SINK}	$V_{CC}=5\text{V}$, $R_L=50\Omega$	10	20	-	mA
Output source current	I_{SOURCE}	$V_{CC}=5\text{V}$, $R_L=50\Omega$	10	20	-	mA
Open loop voltage gain	G_{VO}	$V_{IN}=-75\text{dB}$, $f=1\text{kHz}$	-	75	-	dB
Ripple rejection ratio	RR_{OP}	$V_{IN}=-20\text{dB}$, $f=120\text{Hz}$	-	65	-	dB
Slew rate	SR_{OP}	$f=120\text{kHz}$, $2V_{p-p}$	-	1	-	V / μs
Common mode rejection ratio	CMRR	$V_{IN}=-20\text{dB}$, $f=1\text{kHz}$	-	80	-	dB
Common mode input range	V_{ICM}	$V_{CC}=8\text{V}$	-0.3	-	6.8	V

Application Information

1. REFERENCE INPUT & ALL MUTE FUNCTION

Pin 23 (REF) is a reference input pin.

- Reference input
The applied voltage at the reference input pin must be between 1.4V and 6.5V, when $V_{CC}=8.5V$.
- Mute input
The following input conditions must be satisfied for the normal mute function.

All mute on voltage	Below 1V	Mute function operation
All mute off voltage	Above 1.4V	Normal operation

2. PROTECTION FUNCTION

Thermal shutdown (TSD)

- If the chip temperature rises above 175°C, the thermal shutdown (TSD) circuit is activated and the output circuit is in the mute state, that is off state. The thermal shutdown(TSD) circuit has a temperature hysteresis of 25°C

3. FOCUS, TRACKING ACTUATOR, SLED MOTOR DRIVE PART

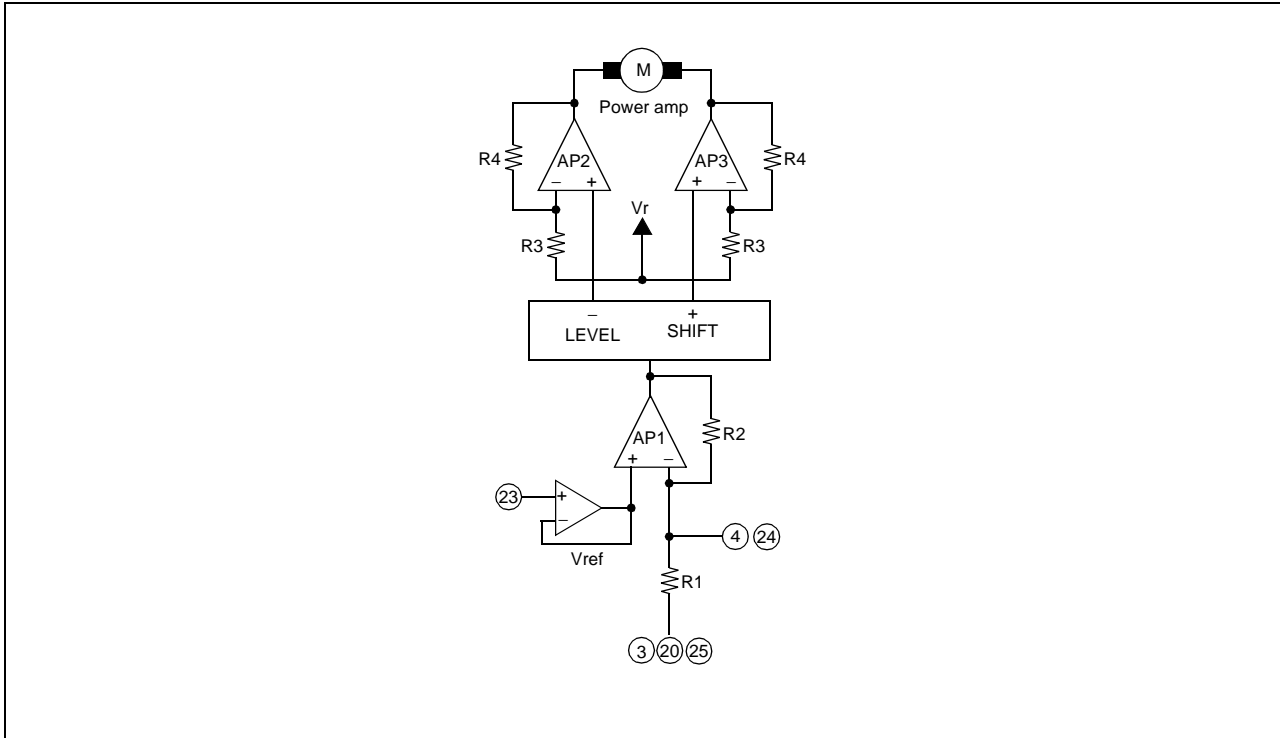

- The reference voltage REF is given externally through pin 23.
- The input signal, pin 3, 20, 25 is amplified by $R2 / R1$ times and then fed to the level shift circuit.
- The level shift circuit produces the differential output voltages and drives the two output power amplifiers. Since the differential gain of the output amplifiers is equal to $2 \times (1 + R4 / R3)$, input signal is amplified by $(R2 / R1) \times 2 \times (1 + R4 / R3)$.
- If the total gain is insufficient, the external resistors can be used through pin 4, 24 to increase the gain.
- The bias voltage (V_{ref}) is about a half of the supply voltage (V_M).

4. TRAY MOTOR DRIVE PART

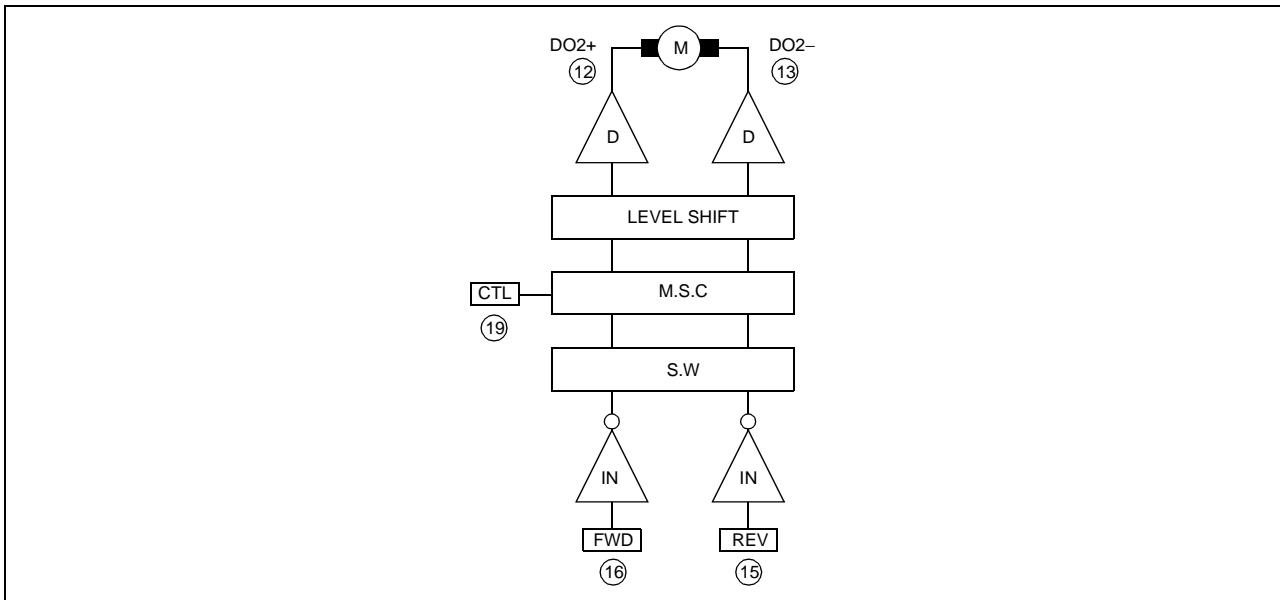

- Rotational direction control

The forward and reverse rotational direction is controlled by FWD (pin 16) and REV (pin 15) inputs.

Conditions are as follows.

Input		Output		
FWD	REV	DO2+	DO2-	State
H	H	Vr	Vr	Brake
H	L	H	L	Forward
L	H	L	H	Reverse
L	L	Vr	Vr	Brake

- Motor speed control

- The motor speed is proportional to the differential voltage between the pin12 (DO2+) and the pin13 (DO2-).
- By applying the voltage to the pin19 of CTL, the motor speed can be controlled and it is linearly proportional to the applied control voltage.
- Motor torque is maximum when pin 19 is open.

Typical Application Circuits

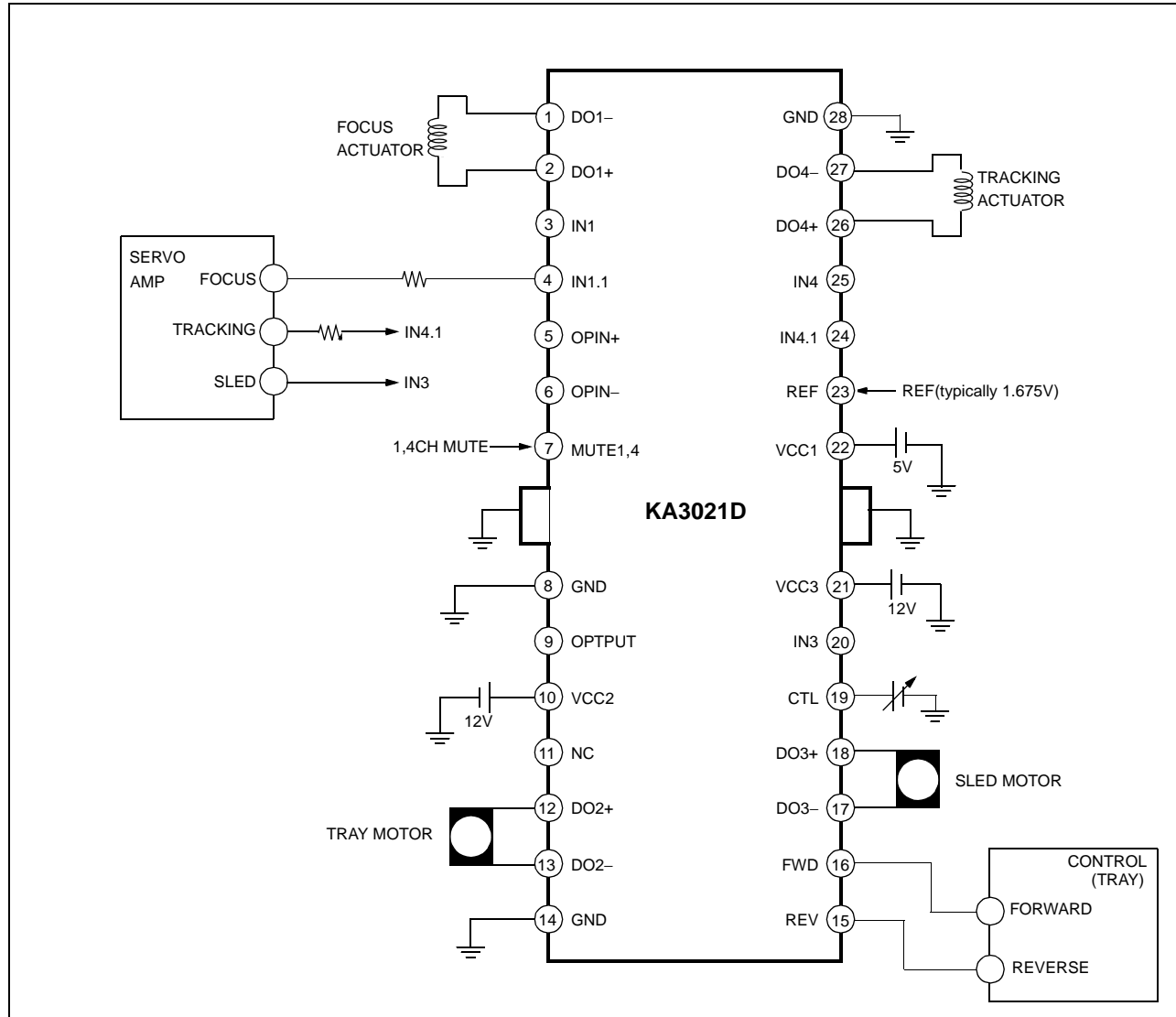

DISCLAIMER

FAIRCHILD SEMICONDUCTOR RESERVES THE RIGHT TO MAKE CHANGES WITHOUT FURTHER NOTICE TO ANY PRODUCTS HEREIN TO IMPROVE RELIABILITY, FUNCTION OR DESIGN. FAIRCHILD DOES NOT ASSUME ANY LIABILITY ARISING OUT OF THE APPLICATION OR USE OF ANY PRODUCT OR CIRCUIT DESCRIBED HEREIN; NEITHER DOES IT CONVEY ANY LICENSE UNDER ITS PATENT RIGHTS, NOR THE RIGHTS OF OTHERS.

LIFE SUPPORT POLICY

FAIRCHILD'S PRODUCTS ARE NOT AUTHORIZED FOR USE AS CRITICAL COMPONENTS IN LIFE SUPPORT DEVICES OR SYSTEMS WITHOUT THE EXPRESS WRITTEN APPROVAL OF THE PRESIDENT OF FAIRCHILD SEMICONDUCTOR INTERNATIONAL. As used herein:

1. Life support devices or systems are devices or systems which, (a) are intended for surgical implant into the body, or (b) support or sustain life, and (c) whose failure to perform when properly used in accordance with instructions for use provided in the labeling, can be reasonably expected to result in a significant injury of the user.
2. A critical component in any component of a life support device or system whose failure to perform can be reasonably expected to cause the failure of the life support device or system, or to affect its safety or effectiveness.