

FAN8700

Camera Motor Drive and Control IC

Features

- Built-in DC Motor Driver
: For Film Winding & Zooming
- Voltage Controlled Stepping Motor Driver
- Built-in AE Meter Driver
- Built-in IRED Driver For Auto-Focus
- Low Drop out Regulator(5V/3V)
- Built-in step-up DC/DC Converter Controller

Description

The FAN8700 is a monolithic integrated circuit, and suitable for the motor driver (AE, AF, zoom and reel motor driver) and the controller (IRED driver, supply , step-up converter control, etc.) in camera systems.

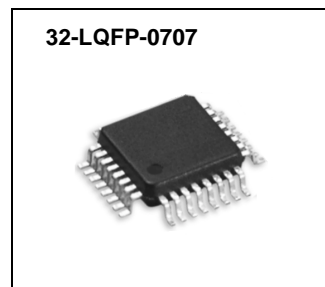

Typical Applications

- Camera system

Ordering Information

Device	Package	Operating Temp.
FAN8700	32-LQFP-0707	-20°C ~ +60°C

Pin Assignments

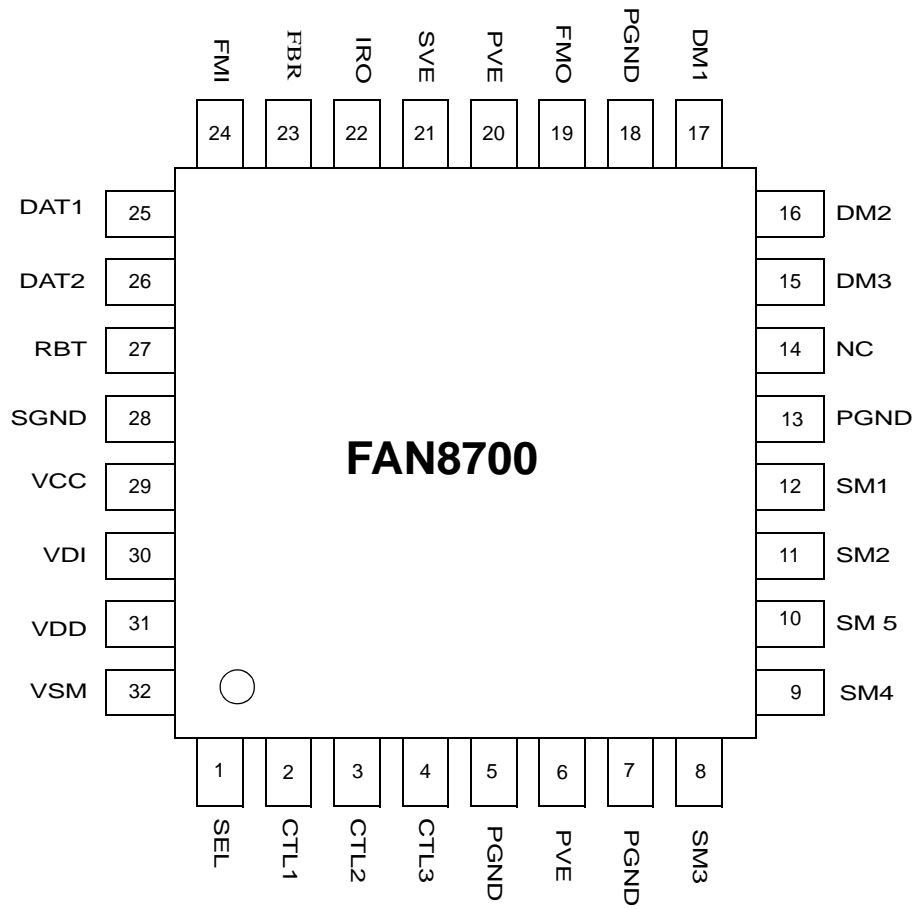

Pin Definitions

Pin Number	Pin Name	Pin Function Description
1	SEL	IC Enable Input
2	CTL ₁	Operating Mode Control Input1
3	CTL ₂	Operating Mode Control Input2
4	CTL ₃	Operating Mode Control Input3
5	PGND	Power Ground
6	PVE	Power VE
7	PGND	Power Ground
8	SM ₃	Stepping Motor Output3
9	SM ₄	Stepping Motor Output4 /AE Meter Output
10	SM ₅	Stepping Motor Output5 /AE Meter Output
11	SM ₂	Stepping Motor Output2
12	SM ₁	Stepping Motor Output1
13	PGND	Power Ground
14	NC	No Connection
15	DM ₃	DC Motor Output 3
16	DM ₂	DC Motor Output 2
17	DM ₁	DC Motor Output 1
18	PGND	Power Ground
19	FMO	Step-up Converter Switching Output
20	PVE	Power VE
21	SVE	Signal VE
22	IRO	IRED drive output
23	FBR	IRED Drive Current Setting Input
24	FMI	Step-up converter switching Clock input
25	DAT ₁	Each Mode Output Control Input1
26	DAT ₂	Each Mode Output Control Input2
27	RBT	VE Voltage Divided Output
28	SGND	Signal Ground
29	VCC	Low Drop-out Regulator Output
30	VDI	Setp-up Output Voltage Feedback Input
31	VDD	Low Drop-out Regulator Output
32	VSM	Stepping Motor Output Voltage Control Input

Internal Block Diagram

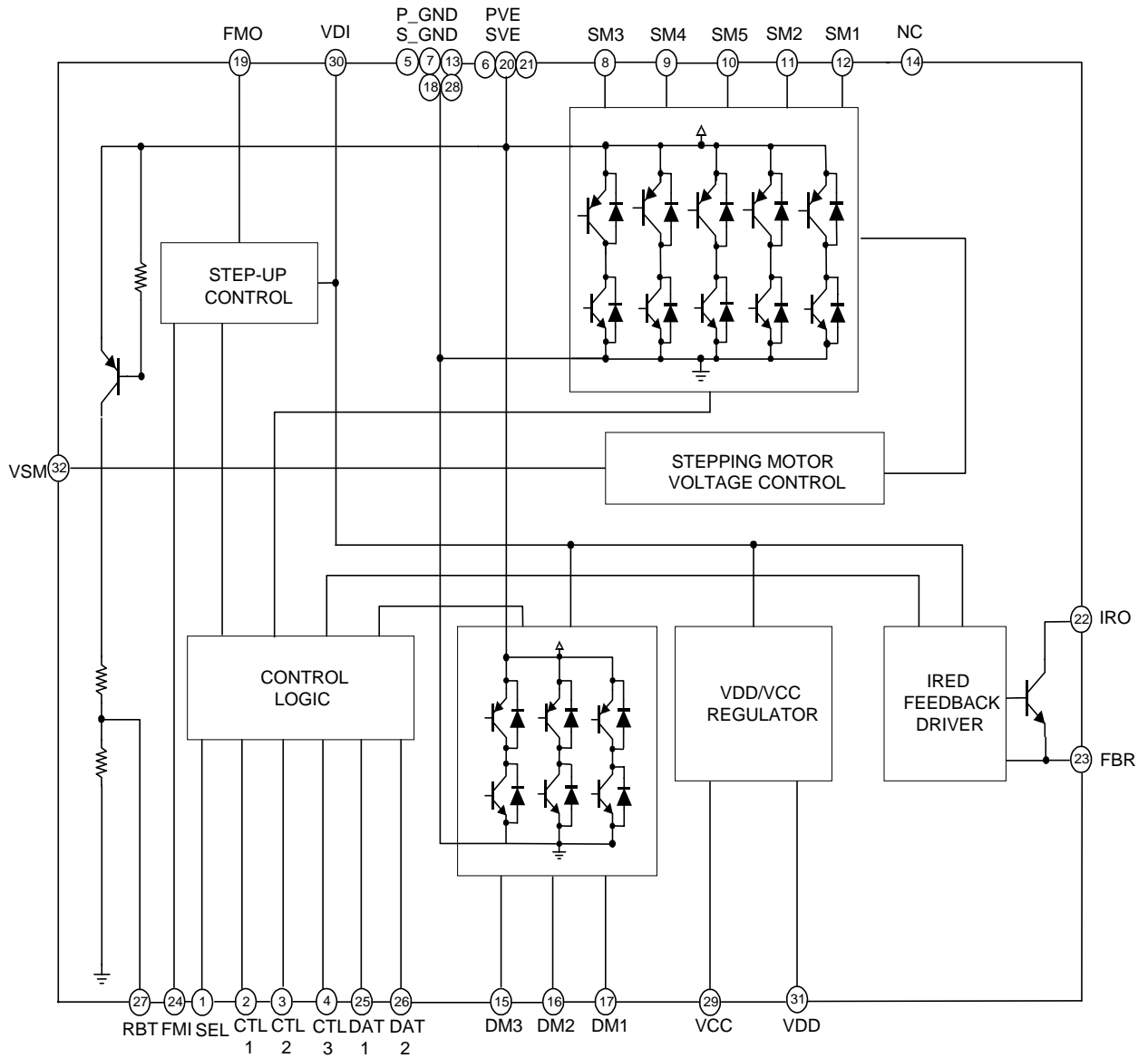

Equivalent Circuits

Description	Pin No.	Internal Circuit	
1.5-Channel DC Motor Drive Block			
SEL	1		
CTL1~3	2~4		
DAT1~2	25,26		
DM1	17		
DM2	16		
DM3	15		
PVE	6,20		
P_GND	5,7,13,18		
Step-up Control Block			
SEL	1		
CTL1~3	2~4		
DAT1~2	25,26		
SM1	12		
SM2	11		
SM3	8		
SM4	9		
SM5	10		
P_GND	5,7,13,18		
IRED Drive Block			
SEL	1		
CTL1~3	2~4		
DAT1~2	25,26		
IRO	22		
FBR	23		

Equivalent Circuits (Continued)

Description	Pin No.	Internal Circuit
Step-up Control Block		
SEL	1	
FMI	24	
VDI	30	
FMO	19	
P_GND	5, 7, 13, 18	
Regulator Block		
SEL	1	
VCC	29	
VDD	31	
P_GND	5, 7, 13, 18	
RBT Block		
SEL	1	
RBT	27	
P_GND	5, 7, 13, 18	

Absolute Maximum Ratings (Ta=25°C)

Parameter	Symbol	Value	Unit	Remark
Supply voltage	VE	4.5	V	-
VCC output current	IVCC	50	mA	-
VDD output current	IVDD	80	mA	-
Stepping motor output current	ISM1,2,3,4,5	500	mA	-
DC motor output current	IDM	2000	mA	500ms
IRED output current	IRED	2000	mA	(3000mA/10mS)
Output terminal voltage	VOUT	5.5	V	500us
Input terminal voltage	VIN	5.5	V	-
Power dissipation	PD	1.9	W	-
Thermal resistance	Rja	65	°C/W	-
Operating temperature range	TOPR	-20 ~ +60	°C	-
Storage temperature range	TSTG	-55 ~ +125	°C	-

Power Dissipation Curve

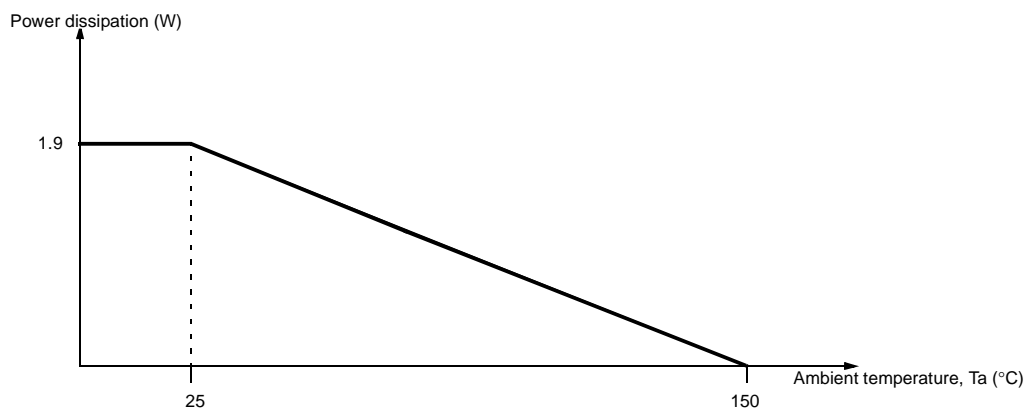

Note:

1. PCB Information (Ref. EIA/JSED51-3 and EIA/JSED51-7)
2. Board Layer : 1 Layer
3. Board Thickness : 1.6mm
4. Board Dimension : 76.2 X 114.3 mm

Recommended Operating Conditions (Ta = 25°C)

Parameter	Symbol	Min.	Typ.	Max.	Unit
Operating supply voltage	VE	2.0	-	4.0	V

Electrical Characteristics

(Ta = -20°C ~ 60°C, VE = 2V)

Block	Characteristics	Symbol	Condition	Min.	Typ.	Max.	Unit
Total	Leakage Current	ISTB	VE = 4.0V, VSEL = 0V	-	-	1.0	mA
	Input Threshold Voltage	VIT	-	0.75	1.1	1.5	V
	Input High Current	I _{IH}	V _{IH} = 3V	-	-	150	mA
Step-up & DC-DC CONVERTER	Minimum Operating Voltage	VOPR1	-	-	-	1.0	V
	Step-up Output Voltage 1	VVDI1	I _{LOAD} =100mA	5.3	5.5	5.7	V
	Step-up Output Voltage 2	VVDI2	I _{LOAD} =100mA	8.3	8.6	8.9	
	FMO Output Voltage 1	VSAT1/1	I _{LOAD} =700mA	-	-	0.3	V
	FMO Output Voltage 2	VSAT1/2	I _{LOAD} =1000mA	-	-	0.4	
	FMI Step-up Clock Range	f	-	39	156	313	KHz
Regulator	VDD Output Voltage	VDD	I _{VDD} =60mA	2.85	3.0	3.15	V
	VDD Drop-out Voltage	VSAT2/1	I _{VDD} =60mA, VDD=2V	-	-	0.3	
	VCC Output Voltage	VCC	I _{VCC} =40mA	4.8	5.00	5.2	V
	VCC Drop-out Voltage	VSAT2/2	I _{VCC} =40mA, VCC=3V	-	-	0.3	V
RBT	Minimum Operating Voltage	VOPR3	-	-	-	1.5	V
	Stand-by Output Voltage	VSTB	VE=4V, VSEL=0V	-	-	0.1	V
	Output Voltage	VRBT	-	0.47	0.5	0.53	× VE
	Output Voltage Temperature Coefficient	VT	-	-	-	2.0	mV/°C
DC Motor	Minimum Operating Voltage	VOPR4	-	-	-	1.0	V
	Output Saturation Voltage	VSAT4	VE=1.6V, I _{DM} =400mA	-	-	0.45	V
Step motor Driver	Minimum Operating Voltage	VOPR5	-	-	-	1.6	V
	Output Saturation Voltage	VSAT5	VE=2.6V, I _{SM} =500mA	-	-	0.7	V
	Output Voltage Relative Difference	DV	VE=2.6V V _{SM} =1.0V, R _L =10W SM1-2, SM3-4	-0.1	0	0.1	V
	Output Voltage 1 (Output Pin to Ground)	VO1	VE=2.6V, R _L =10W, V _{SM} =1.0V SM1, SM2, SM3, SM4	1.9	2.0	2.1	V
	Output Voltage 2 (Output Pin to Ground)	VO2	VE=2.6V, R _L =5W, V _{SM} =1.0V, SM4, SM5	1.85	1.95	2.05	V
Ired	Minimum Operating Voltage	VOPR6	-	-	-	1.5	V
	Output Saturation Voltage	VSAT6	I _{IRED} =1000mA	-	-	1.0	V
	Output Current	I _{IRED}	R _{FBR} =0.3W	0.9	1.0	1.1	A

Control Code Table

Mode	Sel	Ctl1	Ctl2	Ctl3	Dat1	Dat2	Output Port				Remark	
-	-	L	L	L	-	-	-	-	-	-	-	-
-	-	-	-	-	-	-	SM1	SM2	SM3	SM4		
Stepping Motor Drive	H	H	L	H	L	L	L	H	L	H		
					L	H	L	H	H	L		
					H	L	H	L	L	H		
					H	H	H	L	H	L		
-	-	-	-	-	-	-	SM4	SM5	-	-		
Ae Meter Drive	H	H	L	L	L	L	OFF	OFF	-	-		
					L	H	H	L	-	-		
					H	L	L	H	-	-		
					H	H	L	L	-	-		
Ired	H	H	H	H	L	L	-	-	-	-	5.5V Step-up	
					L	H	-	-	-	-	8.6V Step-up	
					H	L	-	-	-	-	Ired On Step-up Off	
					H	H	-	-	-	-	5.5V Step-up	
-	-	-	-	-	-	-	CTL	DM1	DM2	DM3	-	
Dcmotor1 Control	H	L	L	H	L	L	-	OFF	OFF	OFF	OFF	OFF
					L	H	-	H	L	OFF	CW	
					H	L	-	L	H	OFF	CCW	
					H	H	-	L	L	OFF	Brake	
Dcmotor2 Control	H	L	H	L	L	L	-	OFF	OFF	OFF	OFF	
					L	H	-	OFF	H	L	CW	
					H	L	-	OFF	L	H	CCW	
					H	H	-	OFF	L	L	Brake	

Test Circuits

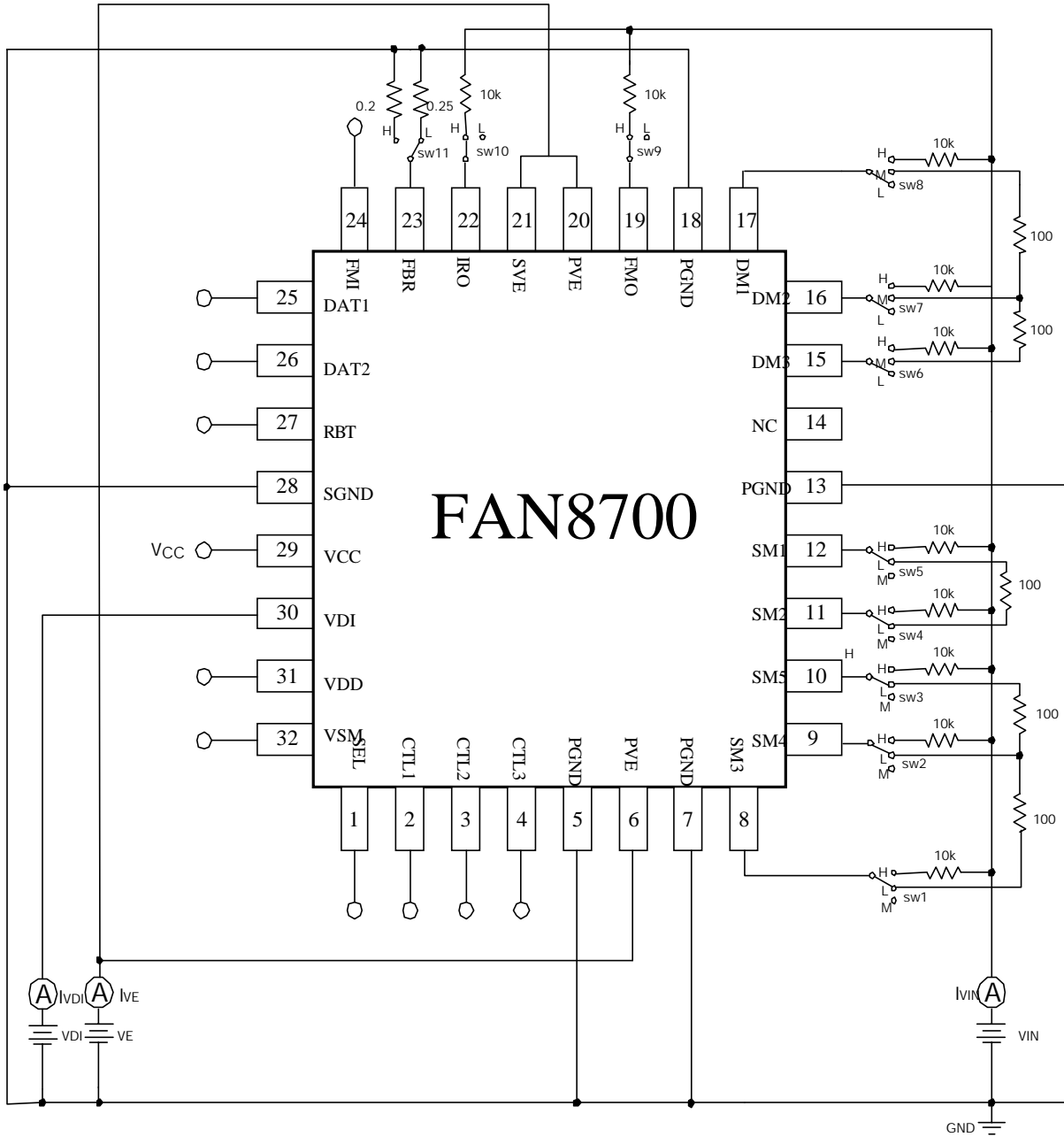

Typical Application Circuits 1

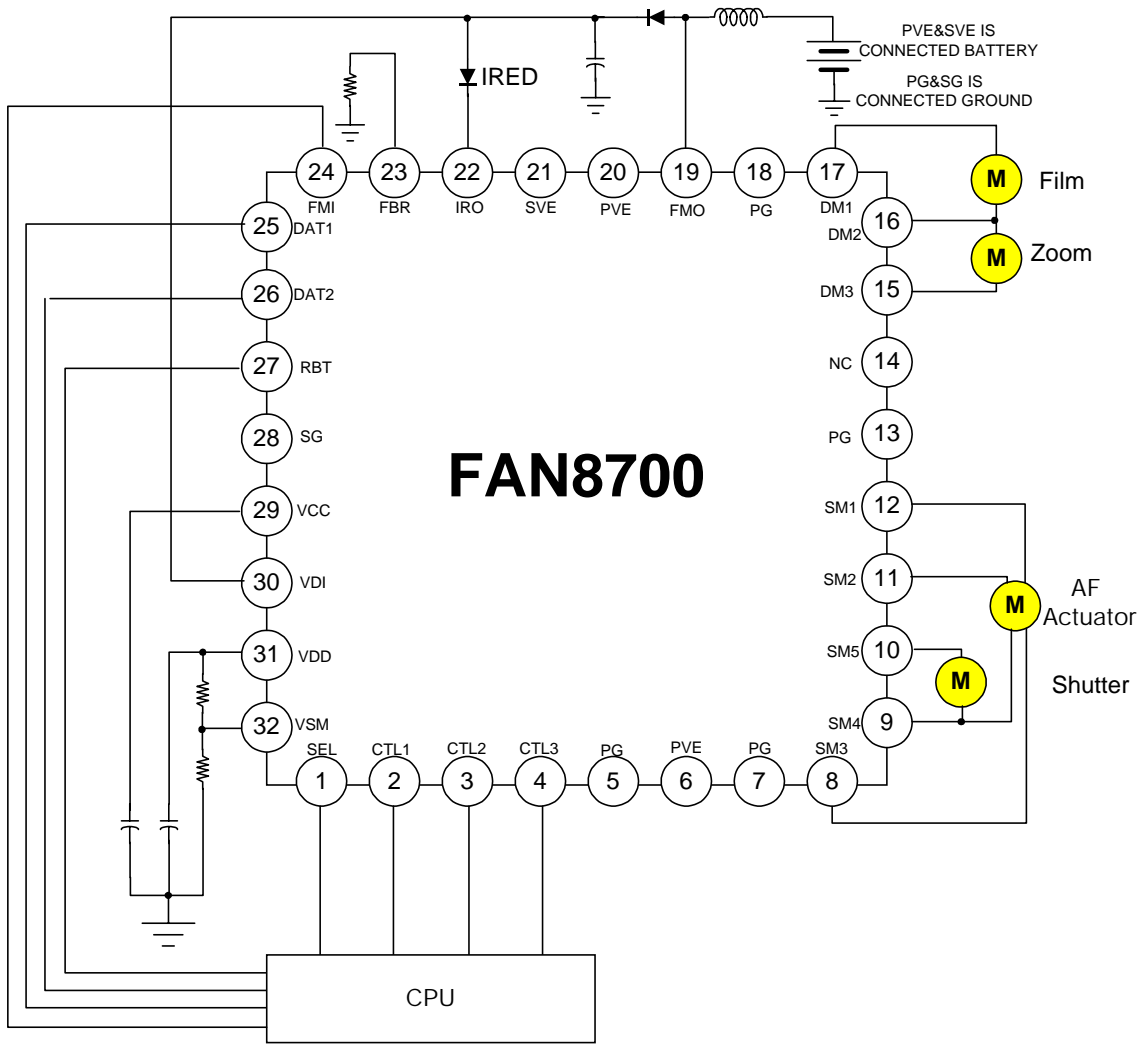

Typical Application Circuits 2

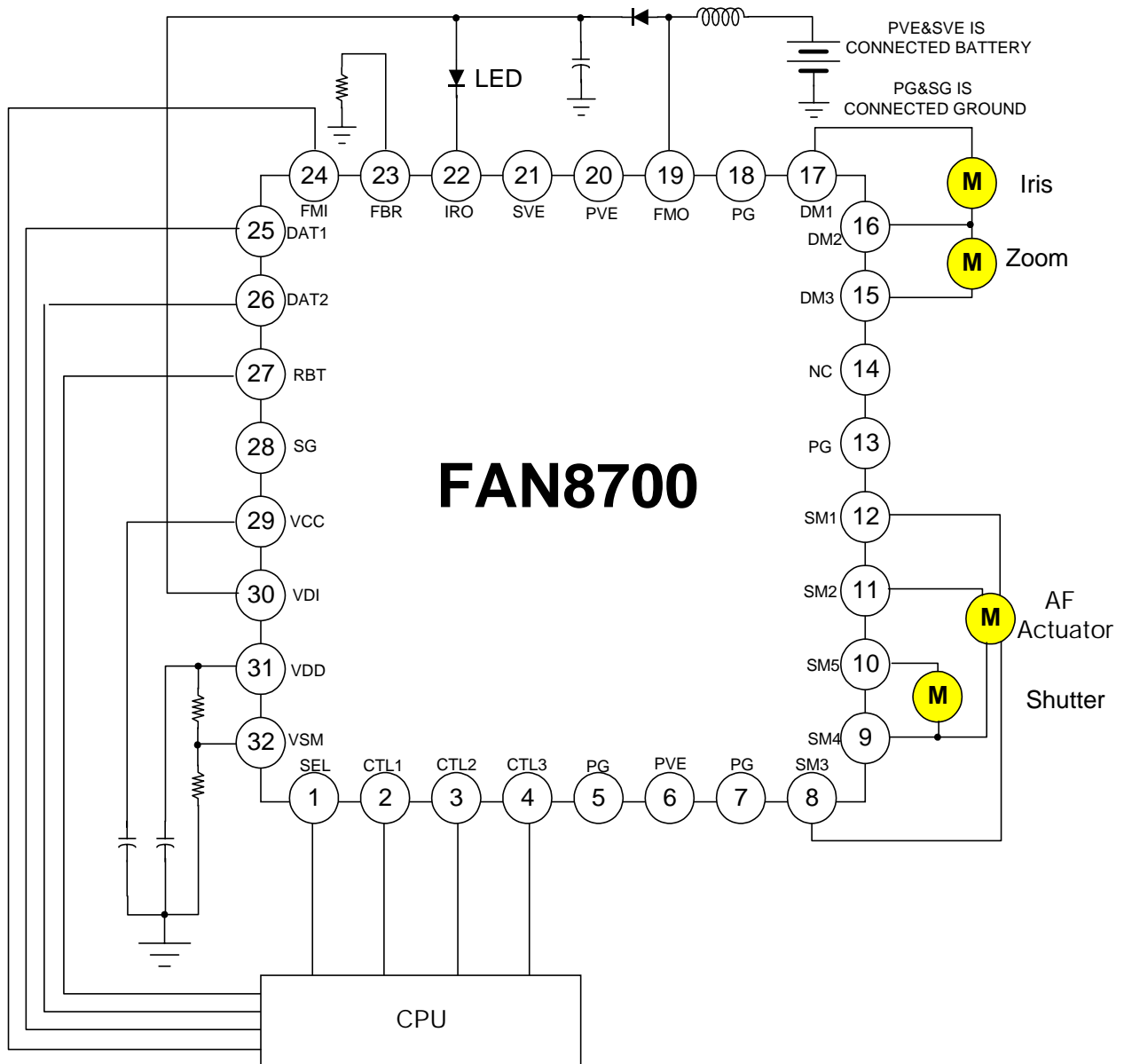

DISCLAIMER

FAIRCHILD SEMICONDUCTOR RESERVES THE RIGHT TO MAKE CHANGES WITHOUT FURTHER NOTICE TO ANY PRODUCTS HEREIN TO IMPROVE RELIABILITY, FUNCTION OR DESIGN. FAIRCHILD DOES NOT ASSUME ANY LIABILITY ARISING OUT OF THE APPLICATION OR USE OF ANY PRODUCT OR CIRCUIT DESCRIBED HEREIN; NEITHER DOES IT CONVEY ANY LICENSE UNDER ITS PATENT RIGHTS, NOR THE RIGHTS OF OTHERS.

LIFE SUPPORT POLICY

FAIRCHILD'S PRODUCTS ARE NOT AUTHORIZED FOR USE AS CRITICAL COMPONENTS IN LIFE SUPPORT DEVICES OR SYSTEMS WITHOUT THE EXPRESS WRITTEN APPROVAL OF THE PRESIDENT OF FAIRCHILD SEMICONDUCTOR CORPORATION. As used herein:

1. Life support devices or systems are devices or systems which, (a) are intended for surgical implant into the body, or (b) support or sustain life, and (c) whose failure to perform when properly used in accordance with instructions for use provided in the labeling, can be reasonably expected to result in a significant injury of the user.
2. A critical component in any component of a life support device or system whose failure to perform can be reasonably expected to cause the failure of the life support device or system, or to affect its safety or effectiveness.