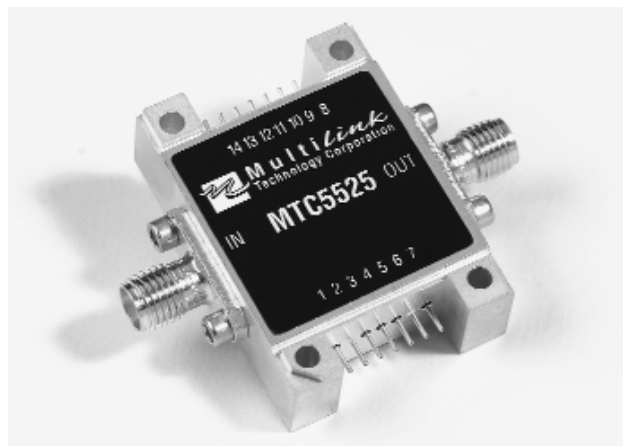

Applications

- Driver for LiNbO₃ modulator in high bit rate SONET/SDH transmission systems

Features:

- High sensitivity input limiter
- 7.25 Voltage amplitude output
- 2 Volt output amplitude control range
- Operates up to 11.0 Gb/s
- Low jitter
- Small form factor

Description

The MTC5525 is a precision GaAs module for driving LiNbO₃ modulators. It provides an AC coupled single-ended input and output, amplitude control and crossing point control. The input stage of the MTC5525 provides a limiting amplifier function to ensure high quality output signal characteristics, even with less than optimal input signals. Key specifications include the MTC5525's low output jitter, high voltage drive capability, high input sensitivity, wide output amplitude control range, small form factor and it's ability to drive at up to 11.0 Gb/s. In addition, the MTC5525's amplitude control feature is specially designed to provide consistent output signal shape over the range of control.

The MTC5525 uses field-replaceable SMA connectors that can be specified as male or female. The module is hermetically sealed and can operate over a case temperature range of -5°C to 70°C and consumes 6W of power.

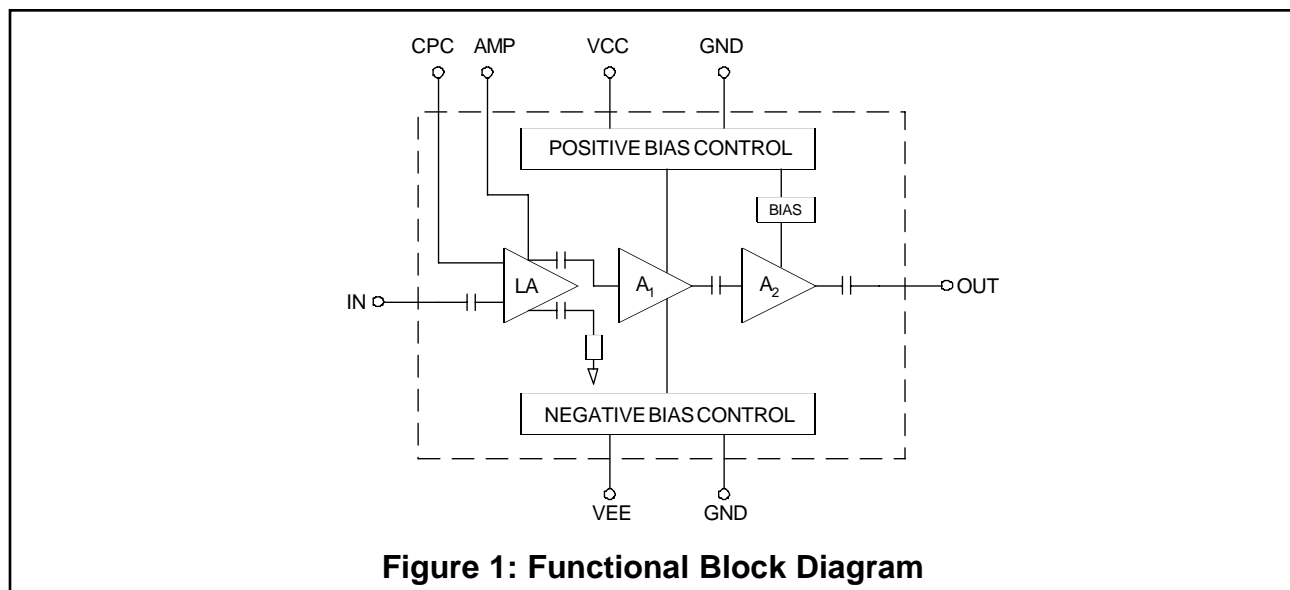
Figure 1: Functional Block Diagram

Absolute Maximum Ratings

Caution: Exceeding the absolute maximum ratings may cause damage to this product and/or lead to reduced reliability. Functional performance is specified over the recommended operating conditions for power supply and temperature only. Electrical characteristics at, or beyond, the absolute maximum ratings are not assured or implied.

Parameter	Min	Max	Units
Positive Voltage Bias		+11	V
Negative Voltage Bias	-6		V
Output Amplitude Control Voltage	-6	+6	V
Crossing Point Control	$-2 * V_{in\ pp}$	$+2 * V_{in\ pp}$	V
Output DC Offset Control Voltage	-5	+5	V
Input Signal Voltage (pp)		1.2	V
Operating Case Temperature	-10	+80	°C
Storage Temperature	-45	+125	°C
DC Voltage Applied to RF Output Pin	-5	+5	V

Recommended Operating Conditions and Power Supply Requirements

Positive Supply Voltage (V_{CC}).....	+9.5V (+/- 5%)
Positive Drain Current (I_{CC}).....	480 mA
Negative Supply Voltage (V_{EE}).....	-5.2 (+/-5%)
Negative Drain Current (I_{EE}).....	275 mA
Operating Temperature Range (case).....	-5°C to +70°C

Electrical Characteristics
 $V_{CC} = +9.5V$ (+/- 5%), $V_{EE} = -5.2V$ (+/- 5%), $T_C = -5^{\circ}C$ to $70^{\circ}C$

 Typical values are $V_{CC} = +9.5V$, $V_{EE} = -5.2V$, $T_C = 25^{\circ}C$

Description	Parameter	Symbol	Min	Typ	Max	Unit	Condition	Notes
Input Data Rate		Data Rate	9		11.0	Gb/s	NRZ	
Low -3dB Bandwidth		BW_{Lo-3dB}		30	50	kHz		
Input Match	50 MHz - 10 GHz	S_{11}		-15	-10	dB		
Output Match:	50 MHz - 2 GHz	S_{22}		-12	-8	dB		
	2.1 GHz - 10 GHz	S_{22}		-12	-9	dB		
Input Voltage Range (pp)		V_{in}	0.4		1.0	V_{PP}		
Output Amplitude Control		V_{ctrl}	-5.0		5.0	V		
Output Voltage Amplitude		$V_{amp-min}$			5.25	V_{amp}	amp = -5V	1, 2
Output Voltage Amplitude		$V_{amp-max}$	7.25			V_{amp}	amp = +5V	1, 2
Output Voltage Ripple		V_{RIPPLE}		+/-10	+/-20	%		
10 MHz Pulse Response:	Over/undershoot	P_R		10	15	%		
	Droop	P_R		10	15	%		
Rise/Fall Time	20% - 80%	t_r / t_f		30	38	ps		
Crossing Point Control		CPC	40		60	%		3

Notes:

1. Upon request, the factory can adjust the output voltage range to selected higher or lower settings (e.g. 4.5 - 6.5 V_{amp}).
2. V_{amp} is the difference between the mean high and mean low signal values (not to be confused with V_{pp} which is the absolute high and low signal values).
3. Can be left unconnected for normal operation. If left unconnected crossing point will be 50% (+/- 5%).

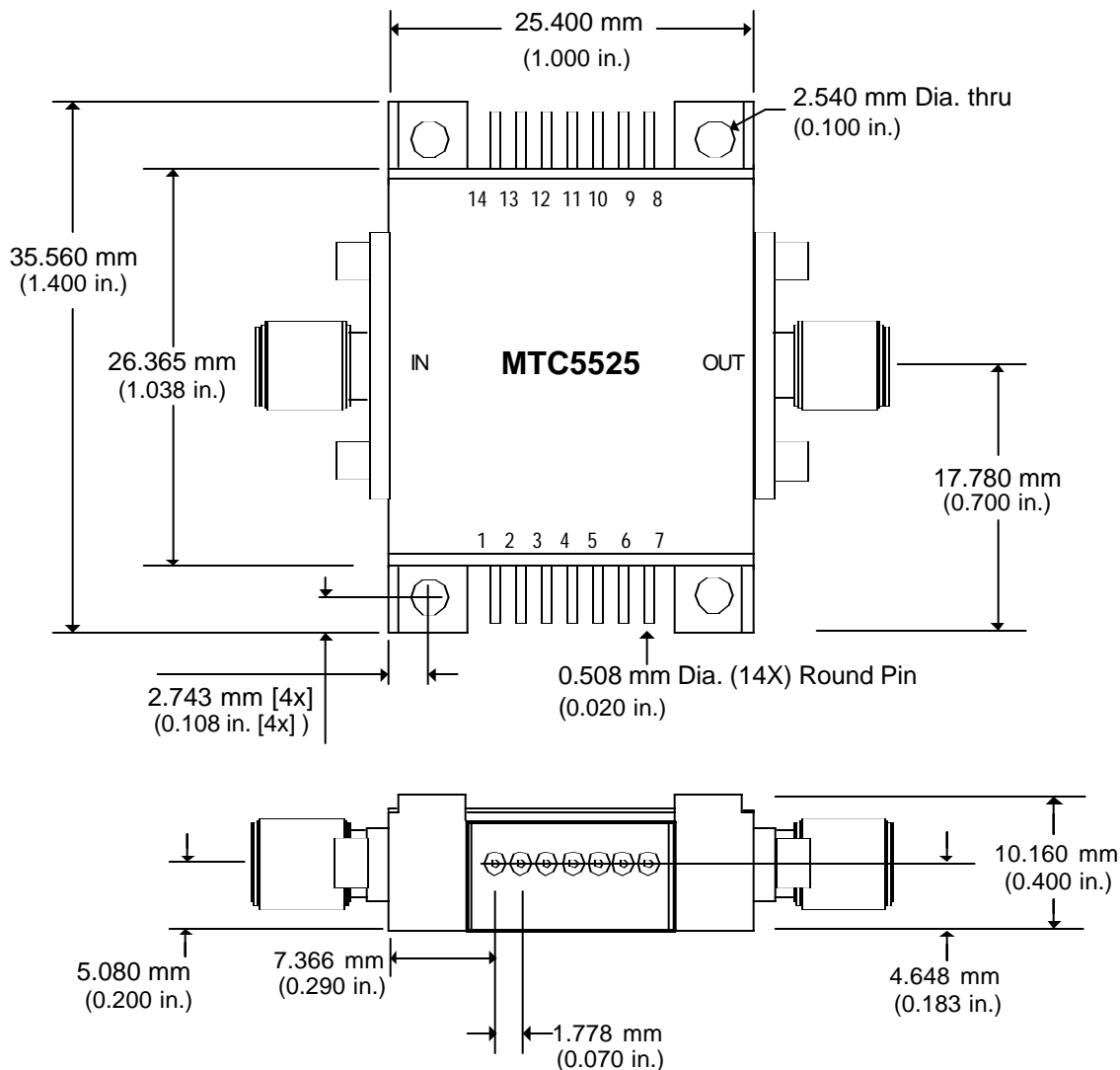

Input / Output ports 50 Ohm, AC coupled.
All tolerances +/-0.254 mm (0.01 in.).
Recommended mounting screw is #2-56.

Figure 2: Package Dimensions

(Drawing not to scale)

Pin Assignments

Pin	Symbol	Parameter
1	V _{EE}	Negative Voltage Bias
2	GND	Ground
3	N.C.	No Connect
4	N.C.	No Connect
5	N.C.	No Connect
6	GND	Ground
7	N.C.	No Connect
8	N.C.	No Connect
9	GND	Ground
10	V _{CC}	Positive Voltage Bias
11	AMP	Output Amplitude Control
12	N.C.	No Connect
13	GND	Ground
14	CPC	Crossing Point Control
IN	IN	RF Input Port
OUT	OUT	RF Output Port

Typical Output Response

+V = +9.5V, -V = -5.2V, T_C = 25°C

Input Voltage 400mV_{pp}, 10 Gb/s, 2³¹-1 PRBS

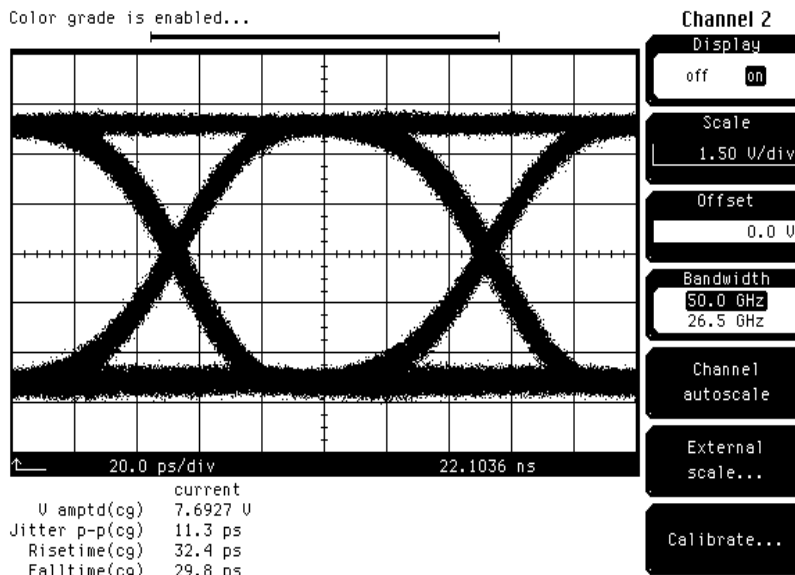

Input Voltage 1000mV_{pp}, 10 Gb/s, 2³¹-1 PRBS

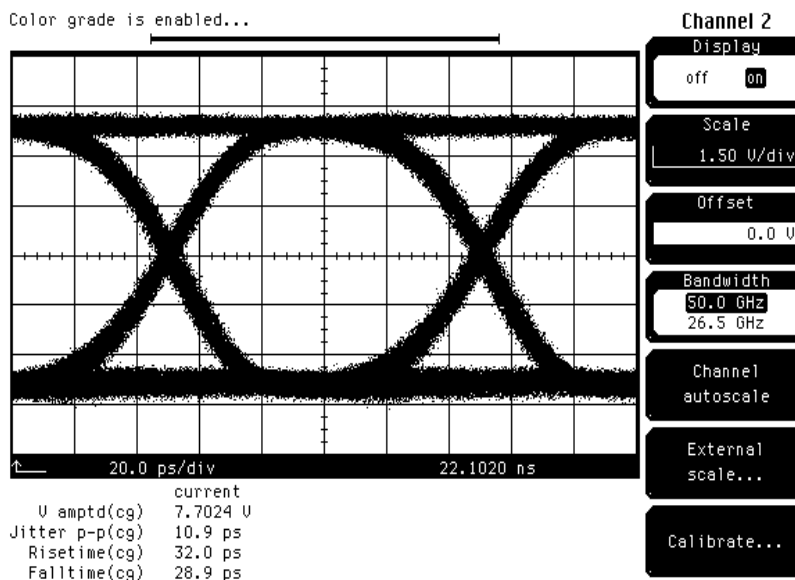

Figure 3: Output Eye Diagrams

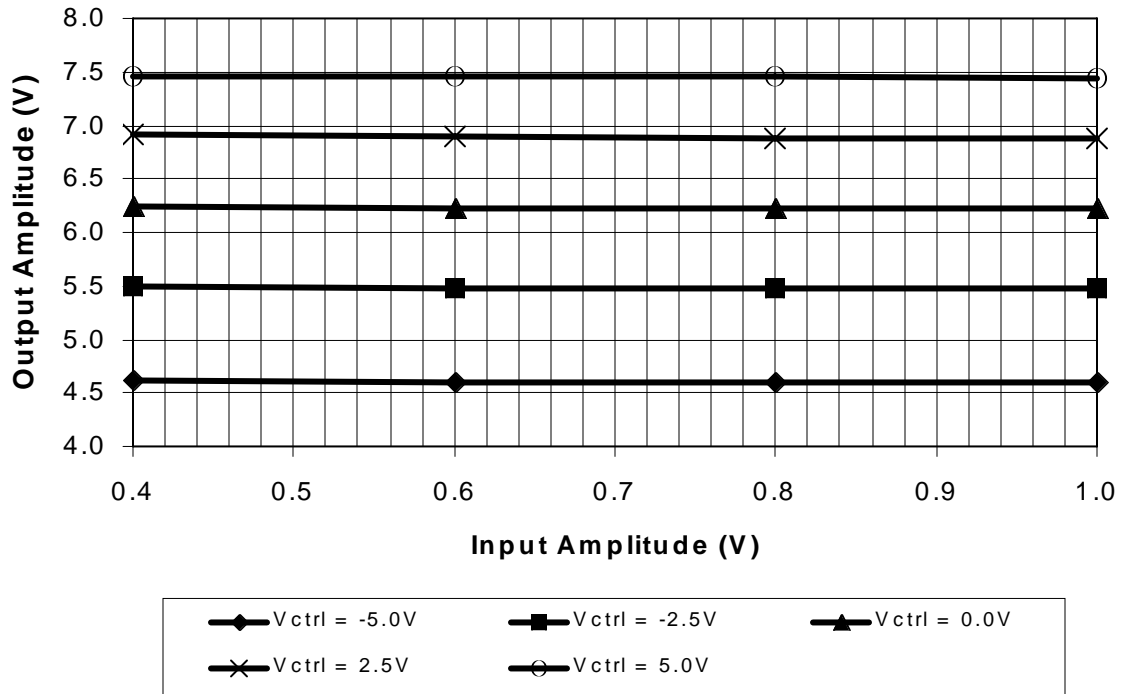

Figure 4: Input versus Output Amplitude

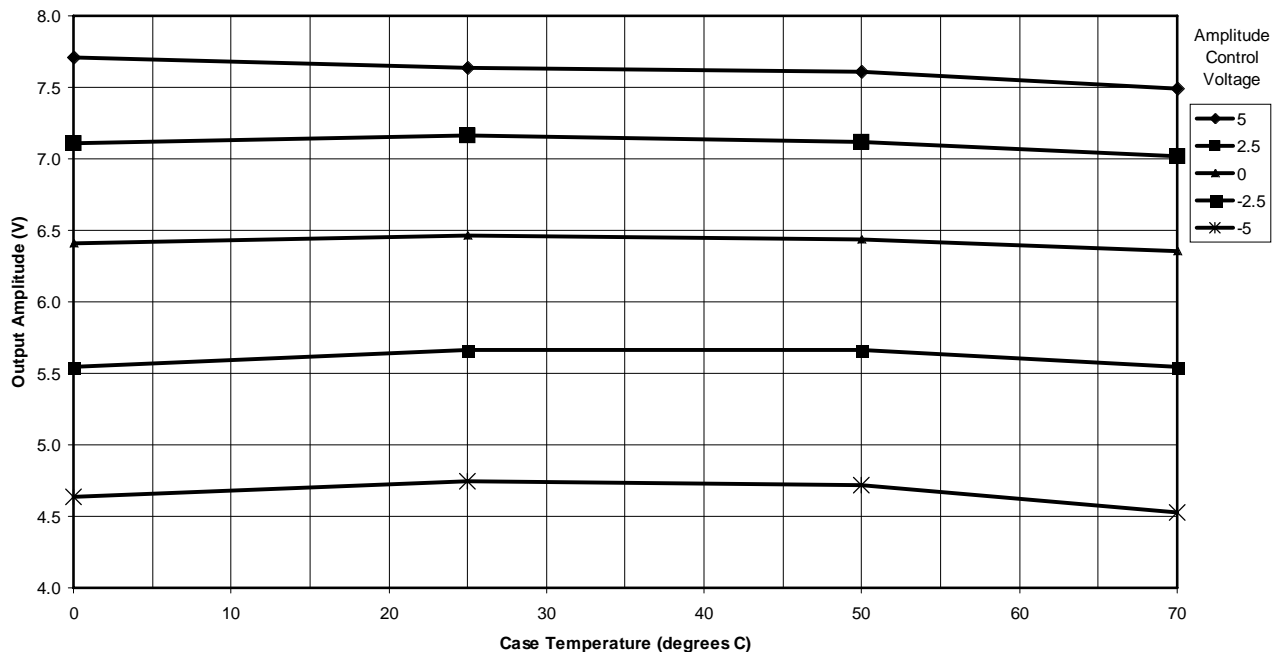

Figure 5: Output Amplitude versus Temperature

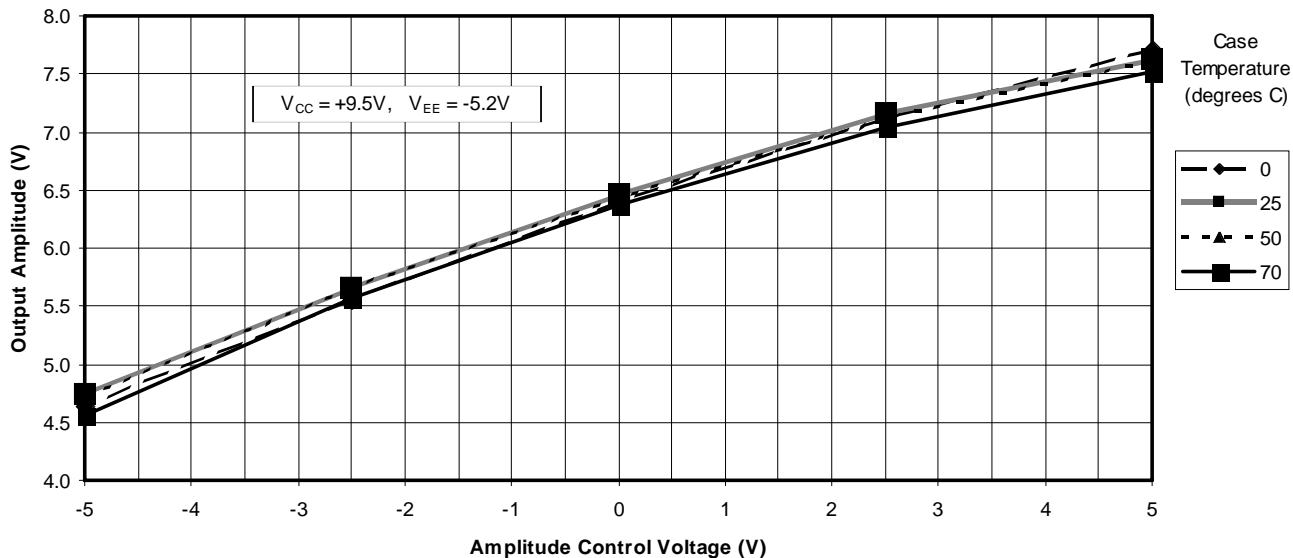

Figure 6: Amplitude Transfer Curve

Limiting Modulator Driver

**MTC5525
Preliminary Data Sheet**

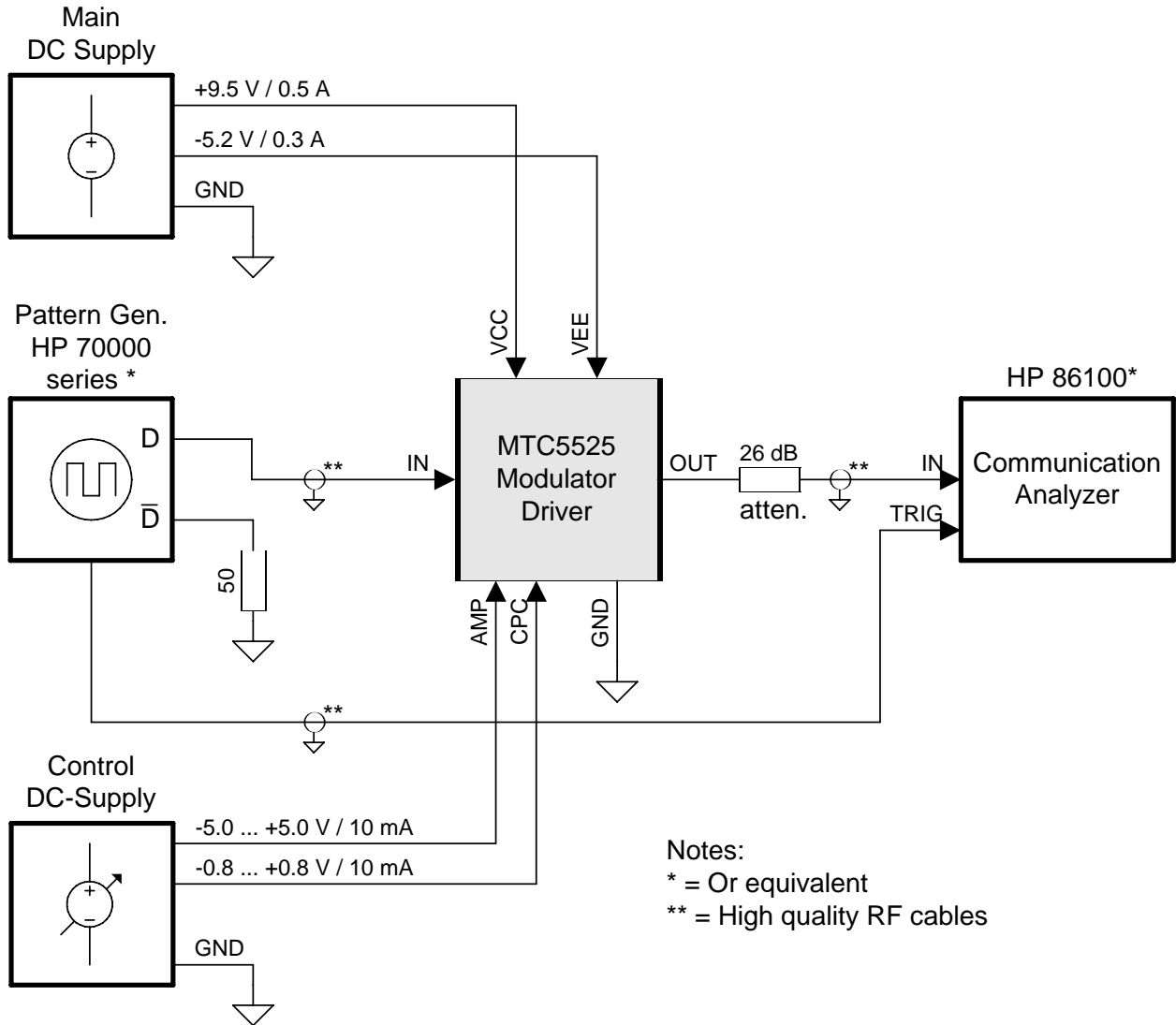

Figure 7: Test Setup Block Diagram

Ordering Information

Part #:
MTC5525

Description:
Limiting Modulator Driver

**For additional ordering information, please contact
in the U.S. or Asia/Pacific:**

in Europe, the Middle East, or Africa:

Multilink Technology Corporation
300 Atrium Drive, 2nd Floor
Somerset, NJ 08873
Phone: Toll-free in the U.S.A. at
888-884-5811 or call
732-537-3700
Fax: (732) 805-9177
E-mail: sales@mltc.com

Multilink Technology GmbH
Bessemerstr. 80
44793 Bochum, Germany
Phone: +49 (234) 91 173 12
Fax: +49 (234) 91 173 18
E-mail: sales@multilink.de

Visit Us on the Internet at <<http://www.mltc.com>>