

# MC100EP016A

## 3.3 V ECL 8-Bit Synchronous Binary Up Counter

The MC100EP016A is a high-speed synchronous, presettable, cascadeable 8-bit binary counter. Architecture and operation are the same as the ECLinPS™ family MC100E016 with higher operating speed.

The counter features internal feedback to  $\overline{TC}$  gated by the TCLD (Terminal Count Load) pin. When TCLD is LOW (or left open, in which case it is pulled LOW by the internal pulldowns), the  $\overline{TC}$  feedback is disabled, and counting proceeds continuously, with  $\overline{TC}$  going LOW to indicate an all-one state. When TCLD is HIGH, the TC feedback causes the counter to automatically reload upon TC = LOW, thus functioning as a programmable counter. The Qn outputs do not need to be terminated for the count function to operate properly. To minimize noise and power, unused Q outputs should be left unterminated.

COUT and  $\overline{COUT}$  provide differential outputs from a single, non-cascaded counter or divider application. COUT and  $\overline{COUT}$  should not be used in cascade configuration. Only  $\overline{TC}$  should be used for a counter or divider cascade chain output.

A differential clock input has also been added to improve performance.

The 100 Series contains temperature compensation.

- 550 ps Typical Propagation Delay
- Operation Frequency > 1.3 GHz is 30% Faster than MC100EP016
- PECL Mode Operating Range:  $V_{CC} = 3.0\text{ V}$  to  $3.6\text{ V}$  with  $V_{EE} = 0\text{ V}$
- NECL Mode Operating Range:  $V_{CC} = 0\text{ V}$  with  $V_{EE} = -3.0\text{ V}$  to  $-3.6\text{ V}$
- Open Input Default State
- Safety Clamp on Clock Inputs
- Internal  $\overline{TC}$  Feedback (Gated)
- Addition of COUT and  $\overline{COUT}$
- 8-Bit
- Differential Clock Input
- $V_{BB}$  Output
- Fully Synchronous Counting and  $\overline{TC}$  Generation
- Asynchronous Master Reset



ON Semiconductor®

<http://onsemi.com>

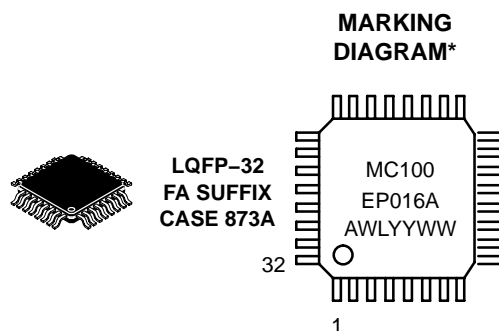

A = Assembly Location  
WL = Wafer Lot  
YY = Year  
WW = Work Week

\*For additional information, see Application Note AND8002/D

### ORDERING INFORMATION

| Device          | Package | Shipping†        |
|-----------------|---------|------------------|
| MC100EP016AFA   | LQFP-32 | 250 Units/Tray   |
| MC100EP016AFAR2 | LQFP-32 | 2000/Tape & Reel |

†For information on tape and reel specifications, including part orientation and tape sizes, please refer to our Tape and Reel Packaging Specifications Brochure, BRD8011/D.

# MC100EP016A

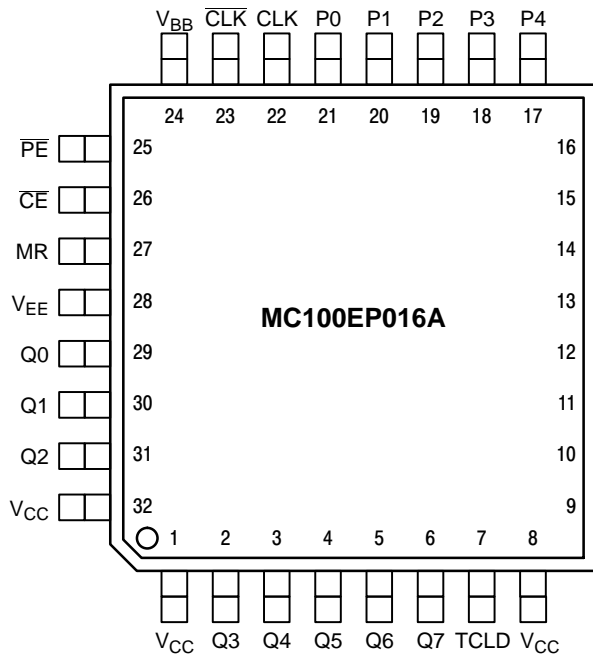

## PIN DESCRIPTION

| PIN                      | FUNCTION                               |
|--------------------------|--|
| P0–P7*                   | ECL Parallel Data (Preset) Inputs      |
| Q0–Q7                    | ECL Data Outputs                       |
| $\overline{CE}^*$        | ECL Count Enable Control Input         |
| $\overline{PE}^*$        | ECL Parallel Load Enable Control Input |
| MR*                      | ECL Master Reset                       |
| CLK*, $\overline{CLK}^*$ | ECL Differential Clock                 |
| $\overline{TC}$          | ECL Terminal Count Output              |
| TCLD*                    | ECL TC–Load Control Input              |
| COUT, COUT               | ECL Differential Output                |
| VCC                      | Positive Supply                        |
| VEE                      | Negative Supply                        |
| VBB                      | Reference Voltage Output               |

\* Pins will default LOW when left open.

Warning: All VCC and VEE pins must be externally connected to Power Supply to guarantee proper operation.

Figure 1. 32-Lead LQFP Pinout (Top View)

## FUNCTION TABLES

| $\overline{CE}$ | $\overline{PE}$ | TCLD | MR | CLK | FUNCTION                                      |
|-----------------|-----------------|------|----|-----|---|
| X               | L               | X    | L  | Z   | Load Parallel (Pn to Qn)                      |
| L               | H               | L    | L  | Z   | Continuous Count                              |
| L               | H               | H    | L  | Z   | Count; Load Parallel on $\overline{TC}$ = LOW |
| H               | H               | X    | L  | Z   | Hold  |
| X               | X               | X    | L  | ZZ  | Masters Respond, Slaves Hold                  |
| X               | X               | X    | H  | X   | Reset (Qn := LOW, $\overline{TC}$ := HIGH)    |

ZZ = Clock Pulse (High-to-Low)

Z = Clock Pulse (Low-to-High)

## FUNCTION TABLE

| Function               | $\overline{PE}$ | $\overline{CE}$ | MR | TCLD | CLK | P7–P4 | P3 | P2 | P1 | P0 | Q7–Q4 | Q3 | Q2 | Q1 | Q0 | $\overline{TC}$ | COUT | COUT |
|------------------------|-----------------|-----------------|----|------|-----|-------|----|----|----|----|-------|----|----|----|----|-----------------|------|------|
| Load Count             | L               | X               | L  | X    | Z   | H     | H  | H  | L  | L  | H     | H  | H  | L  | L  | H               | H    | L    |
|                        | H               | L               | L  | L    | Z   | X     | X  | X  | X  | X  | H     | H  | H  | L  | L  | H               | H    | L    |
|                        | H               | L               | L  | L    | Z   | X     | X  | X  | X  | X  | H     | H  | H  | H  | H  | L               | H    | L    |
|                        | H               | L               | L  | L    | Z   | X     | X  | X  | X  | X  | L     | L  | L  | L  | L  | H               | H    | L    |
| Load Hold              | L               | X               | L  | X    | Z   | H     | H  | H  | L  | L  | H     | H  | H  | L  | L  | H               | H    | L    |
|                        | H               | H               | L  | X    | Z   | X     | X  | X  | X  | X  | H     | H  | H  | L  | L  | H               | H    | L    |
|                        | H               | H               | L  | X    | Z   | X     | X  | X  | X  | X  | H     | H  | H  | L  | L  | H               | H    | L    |
| Load on Terminal Count | H               | L               | L  | H    | Z   | H     | L  | H  | H  | L  | H     | H  | H  | L  | H  | H               | H    | L    |
|                        | H               | L               | L  | H    | Z   | H     | L  | H  | H  | L  | H     | H  | H  | H  | L  | H               | H    | L    |
|                        | H               | L               | L  | H    | Z   | H     | L  | H  | H  | L  | H     | L  | H  | H  | L  | H               | H    | L    |
|                        | H               | L               | L  | H    | Z   | H     | L  | H  | H  | L  | H     | L  | H  | H  | H  | H               | H    | L    |
|                        | H               | L               | L  | H    | Z   | H     | L  | H  | H  | L  | H     | H  | L  | L  | L  | H               | H    | L    |
| Reset                  | X               | X               | H  | X    | X   | X     | X  | X  | X  | X  | L     | L  | L  | L  | L  | H               | H    | L    |

# MC100EP016A

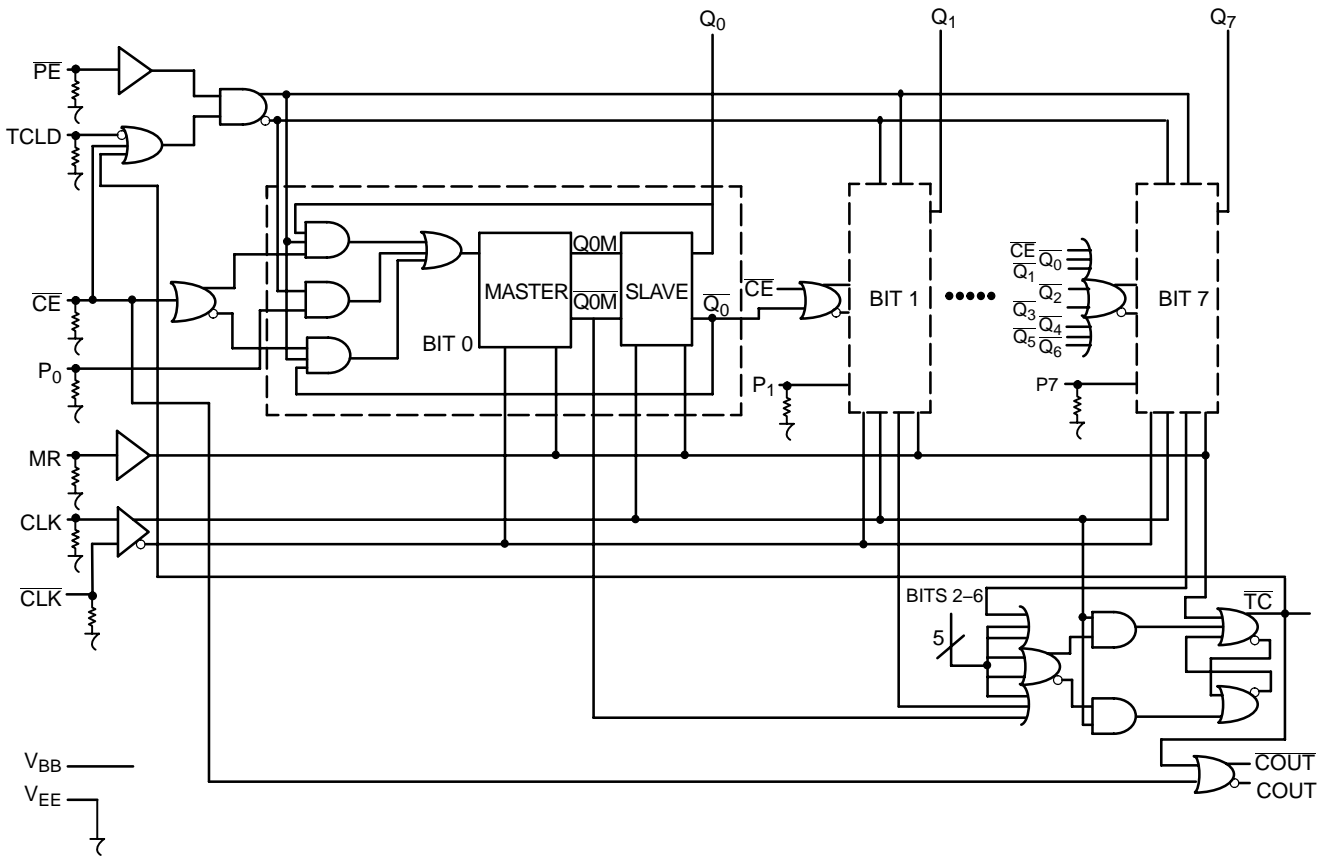

Note that this diagram is provided for understanding of logic operation only. It should not be used for propagation delays as many gate functions are achieved internally without incurring a full gate delay.

**Figure 2. 8-BIT Binary Counter Logic Diagram**

## ATTRIBUTES

| Characteristics  |                        | Value                |
|--|------------------------|----------------------|
| Internal Input Pulldown Resistor                       |                        | 75 kΩ                |
| Internal Input Pullup Resistor                         |                        | N/A                  |
| ESD Protection   | Human Body Model       | > 2 kV               |
|  | Machine Model          | > 100 V              |
|  | Charged Device Model   | > 2 kV               |
| Moisture Sensitivity (Note 1)                          |                        | Level 2              |
| Flammability Rating                                    | Oxygen Index: 28 to 34 | UL 94 V-0 @ 0.125 in |
| Transistor Count                                       |                        | 1226 Devices         |
| Meets or exceeds JEDEC Spec EIA/JESD78 IC Latchup Test |                        |                      |

1. For additional information, see Application Note AND8003/D.

# MC100EP016A

## MAXIMUM RATINGS

| Symbol        | Parameter                                | Condition 1           | Condition 2       | Rating      | Units |
|---------------|--|-----------------------|-------------------|-------------|-------|
| $V_{CC}$      | PECL Mode Power Supply                   | $V_{EE} = 0\text{ V}$ |                   | 6           | V     |
| $V_{EE}$      | NECL Mode Power Supply                   | $V_{CC} = 0\text{ V}$ |                   | -6          | V     |
| $V_I$         | PECL Mode Input Voltage                  | $V_{EE} = 0\text{ V}$ | $V_I \leq V_{CC}$ | 6           | V     |
|               | NECL Mode Input Voltage                  | $V_{CC} = 0\text{ V}$ | $V_I \geq V_{EE}$ | -6          | V     |
| $I_{out}$     | Output Current                           | Continuous<br>Surge   |                   | 50          | mA    |
|               |  |                       |                   | 100         | mA    |
| $I_{BB}$      | $V_{BB}$ Sink/Source                     |                       |                   | $\pm 0.5$   | mA    |
| TA            | Operating Temperature Range              |                       |                   | -40 to +70  | °C    |
| $T_{stg}$     | Storage Temperature Range                |                       |                   | -65 to +150 | °C    |
| $\theta_{JA}$ | Thermal Resistance (Junction to Ambient) | 0 LFPM                | 32 LQFP           | 74          | °C/W  |
|               |  | 500 LFPM              | 32 LQFP           | 61          | °C/W  |
| $\theta_{JC}$ | Thermal Resistance (Junction to Case)    | std bd                | 32 LQFP           | 12 to 17    | °C/W  |
| $T_{sol}$     | Wave Solder                              | <2 to 3 sec @ 248°C   |                   | 265         | °C    |

Maximum ratings are those values beyond which device damage can occur. Maximum ratings applied to the device are individual stress limit values (not normal operating conditions) and are not valid simultaneously. If these limits are exceeded, device functional operation is not implied, damage may occur and reliability may be affected.

# MC100EP016A

## 100EP DC CHARACTERISTICS, PECL $V_{CC} = 3.3\text{ V}$ , $V_{EE} = 0\text{ V}$ (Note 2)

| Symbol      | Characteristic   | -40°C |      |      | 25°C |      |      | 70°C |      |      | Unit          |
|-------------|--|-------|------|------|------|------|------|------|------|------|---------------|
|             |  | Min   | Typ  | Max  | Min  | Typ  | Max  | Min  | Typ  | Max  |               |
| $I_{EE}$    | Power Supply Current   | 130   | 170  | 210  | 130  | 177  | 210  | 130  | 180  | 210  | mA            |
| $V_{OH}$    | Output HIGH Voltage (Note 3)                                 | 2155  | 2280 | 2405 | 2155 | 2280 | 2405 | 2155 | 2280 | 2405 | mV            |
| $V_{OL}$    | Output LOW Voltage (Note 3)                                  | 1355  | 1480 | 1605 | 1355 | 1480 | 1605 | 1355 | 1480 | 1605 | mV            |
| $V_{IH}$    | Input HIGH Voltage (Single Ended)                            | 2075  |      | 2420 | 2075 |      | 2420 | 2075 |      | 2420 | mV            |
| $V_{IL}$    | Input LOW Voltage (Single Ended)                             | 1355  |      | 1675 | 1355 |      | 1675 | 1355 |      | 1675 | mV            |
| $V_{BB}$    | Output Voltage Reference                                     | 1775  | 1875 | 1975 | 1775 | 1875 | 1975 | 1775 | 1875 | 1975 | mV            |
| $V_{IHCMR}$ | Input HIGH Voltage Common Mode Range (Differential) (Note 4) | 2.0   |      | 3.3  | 2.0  |      | 3.3  | 2.0  |      | 3.3  | V             |
| $I_{IH}$    | Input HIGH Current   |       |      | 150  |      |      | 150  |      |      | 150  | $\mu\text{A}$ |
| $I_{IL}$    | Input LOW Current  | 0.5   |      |      | 0.5  |      |      | 0.5  |      |      | $\mu\text{A}$ |

NOTE: EP circuits are designed to meet the DC specifications shown in the above table after thermal equilibrium has been established. The circuit is in a test socket or mounted on a printed circuit board and transverse airflow greater than 500 lfm is maintained.

2. Input and output parameters vary 1:1 with  $V_{CC}$ .  $V_{EE}$  can vary +0.3 V to -0.3 V.

3. All loading with 50 ohms to  $V_{CC}$ -2.0 volts.

4.  $V_{IHCMR}$  min varies 1:1 with  $V_{EE}$ .  $V_{IHCMR}$  max varies 1:1 with  $V_{CC}$ . The  $V_{IHCMR}$  range is referenced to the most positive side of the differential input signal.

## 100EP DC CHARACTERISTICS, NECL $V_{CC} = 0\text{ V}$ , $V_{EE} = -3.6\text{ V}$ to $-3.0\text{ V}$ (Note 5)

| Symbol      | Characteristic   | -40°C        |       |       | 25°C         |       |       | 70°C         |       |       | Unit          |
|-------------|--|--------------|-------|-------|--------------|-------|-------|--------------|-------|-------|---------------|
|             |  | Min          | Typ   | Max   | Min          | Typ   | Max   | Min          | Typ   | Max   |               |
| $I_{EE}$    | Power Supply Current   | 130          | 170   | 210   | 130          | 177   | 210   | 130          | 180   | 210   | mA            |
| $V_{OH}$    | Output HIGH Voltage (Note 6)                                 | -1145        | -1020 | -895  | -1145        | -1020 | -895  | -1145        | -1020 | -895  | mV            |
| $V_{OL}$    | Output LOW Voltage (Note 6)                                  | -1945        | -1820 | -1695 | -1945        | -1820 | -1695 | -1945        | -1820 | -1695 | mV            |
| $V_{IH}$    | Input HIGH Voltage (Single Ended)                            | -1225        |       | -880  | -1225        |       | -880  | -1225        |       | -880  | mV            |
| $V_{IL}$    | Input LOW Voltage (Single Ended)                             | -1945        |       | -1625 | -1945        |       | -1625 | -1945        |       | -1625 | mV            |
| $V_{BB}$    | Output Voltage Reference                                     | -1525        | -1425 | -1325 | -1525        | -1425 | -1325 | -1525        | -1425 | -1325 | mV            |
| $V_{IHCMR}$ | Input HIGH Voltage Common Mode Range (Differential) (Note 7) | $V_{EE}+2.0$ |       | 0.0   | $V_{EE}+2.0$ |       | 0.0   | $V_{EE}+2.0$ |       | 0.0   | V             |
| $I_{IH}$    | Input HIGH Current   |              |       | 150   |              |       | 150   |              |       | 150   | $\mu\text{A}$ |
| $I_{IL}$    | Input LOW Current  | 0.5          |       |       | 0.5          |       |       | 0.5          |       |       | $\mu\text{A}$ |

NOTE: EP circuits are designed to meet the DC specifications shown in the above table after thermal equilibrium has been established. The circuit is in a test socket or mounted on a printed circuit board and transverse airflow greater than 500 lfm is maintained.

5. Input and output parameters vary 1:1 with  $V_{CC}$ .

6. All loading with 50 ohms to  $V_{CC}$ -2.0 volts.

7.  $V_{IHCMR}$  min varies 1:1 with  $V_{EE}$ .  $V_{IHCMR}$  max varies 1:1 with  $V_{CC}$ . The  $V_{IHCMR}$  range is referenced to the most positive side of the differential input signal.

# MC100EP016A

**AC CHARACTERISTICS**  $V_{EE} = -3.0\text{ V to }-3.6\text{ V}$ ;  $V_{CC} = 0\text{ V or }V_{CC} = 3.0\text{ V to }3.6\text{ V}$ ;  $V_{EE} = 0\text{ V}$  (Note 8)

| Symbol                               | Characteristic   | -40°C                                  |   |  | 25°C                                   |   |  | 70°C                                   |   |   | Unit |
|--------------------------------------|--|--|---|--|--|---|--|--|---|---|------|
|                                      |  | Min                                    | Typ                                       | Max                                    | Min                                    | Typ                                       | Max                                    | Min                                    | Typ                                       | Max                                     |      |
| f <sub>COUNT</sub>                   | Maximum Frequency<br>Count & Division Modes<br>Q, $\overline{TC}$ , COUT/ $\overline{COUT}$  | 1.3                                    | 1.5                                       |  | 1.2                                    | 1.4                                       |  | 1.2                                    | 1.3                                       |   | GHz  |
| t <sub>PLH</sub><br>t <sub>PHL</sub> | Propagation Delay<br>CLK to Q<br>MR to Q<br>CLK to $\overline{TC}$<br>MR to $\overline{TC}$<br>CLK to COUT/ $\overline{COUT}$<br>MR to COUT/ $\overline{COUT}$ | 350<br>400<br>350<br>400<br>475<br>450 | 511<br>550<br>511<br>555<br>705<br>720    | 650<br>700<br>650<br>700<br>850<br>850 | 400<br>400<br>400<br>400<br>500<br>500 | 550<br>570<br>550<br>570<br>745<br>760    | 700<br>750<br>700<br>750<br>900<br>900 | 480<br>450<br>480<br>520<br>550<br>570 | 610<br>630<br>610<br>635<br>825<br>830    | 780<br>820<br>780<br>820<br>1000<br>950 | ps   |
| t <sub>S</sub>                       | Setup Time<br>P0<br>P1 to P4<br>P5 to P7<br>$\overline{CE}$<br>$\overline{PE}$<br>TCLD   | 400<br>300<br>250<br>500<br>500<br>550 | 240<br>140<br>80<br>320<br>315<br>355     |  | 400<br>300<br>250<br>500<br>500<br>550 | 240<br>135<br>65<br>330<br>320<br>365     |  | 400<br>300<br>250<br>500<br>500<br>550 | 245<br>125<br>55<br>340<br>325<br>380     |   | ps   |
| t <sub>H</sub>                       | Hold Time<br>P0<br>P1 to P4<br>P5 to P7<br>$\overline{CE}$<br>$\overline{PE}$<br>TCLD  | 100<br>50<br>150<br>600<br>625<br>525  | -145<br>-160<br>-105<br>380<br>465<br>320 |  | 100<br>50<br>150<br>600<br>625<br>525  | -155<br>-170<br>-110<br>410<br>500<br>325 |  | 100<br>50<br>150<br>600<br>625<br>525  | -170<br>-180<br>-115<br>450<br>535<br>340 |   | ps   |
| t <sub>JITTER</sub>                  | Clock Random Jitter<br>(RMS, 1000 Waveforms)   |  | 2.6                                       | 8.5                                    |  | 2.5                                       | 8.0                                    |  | 2.5                                       | 8.0                                     | ps   |
| t <sub>RR</sub>                      | Reset Recovery Time  | 400                                    | 195                                       |  | 400                                    | 205                                       |  | 400                                    | 220                                       |   | ps   |
| t <sub>PW</sub>                      | Minimum Pulse Width CLK<br>Minimum Pulse Width MR  | 550<br>550                             | 365<br>380                                |  | 550<br>550                             | 365<br>380                                |  | 550<br>550                             | 370<br>380                                |   | ps   |
| t <sub>r</sub> , t <sub>f</sub>      | Output Rise/Fall Times<br>20% – 80%  | 90                                     | 180                                       | 320                                    | 100                                    | 190                                       | 320                                    | 125                                    | 215                                       | 450                                     | ps   |

8. Measured using a 750 mV source, 50% duty cycle clock source. All loading with 50 ohms to  $V_{CC} - 2.0\text{ V}$ .

Applications Information

Cascading Multiple EP016A Devices

For applications which call for larger than 8-bit counters multiple EP016As can be tied together to achieve very wide bit width counters. The active low terminal count ( $\overline{TC}$ ) output and count enable input ( $\overline{CE}$ ) greatly facilitate the cascading of EP016A devices. Two EP016As can be cascaded without the need for external gating, however for counters wider than 16 bits external OR gates are necessary for cascade implementations.

Figure 3 below pictorially illustrates the cascading of 4 EP016As to build a 32-bit high frequency counter. Note the EP01 gates used to OR the terminal count outputs of the lower order EP016As to control the counting operation of the higher order bits. When the terminal count of the preceding device (or devices) goes low (the counter reaches an all 1s state) the more significant EP016A is set in its count mode and will count one binary digit upon the next positive clock transition. In addition, the preceding devices will also count one bit thus sending their terminal count outputs back

to a high state disabling the count operation of the more significant counters and placing them back into hold modes. Therefore, for an EP016A in the chain to count, all of the lower order terminal count outputs must be in the low state. The bit width of the counter can be increased or decreased by simply adding or subtracting EP016A devices from Figure 3 and maintaining the logic pattern illustrated in the same figure.

The maximum frequency of operation for a cascaded counter chain is set by the propagation delay of the  $\overline{TC}$  output, the necessary setup time of the  $\overline{CE}$  input, and the propagation delay through the OR gate controlling it (for 16-bit counters the limitation is only the  $\overline{TC}$  propagation delay and the  $\overline{CE}$  setup time). Figure 3 shows EP01 gates used to control the count enable inputs, however, if the frequency of operation is slow enough, a LVECL OR gate can be used. Using the worst case guarantees for these parameters.

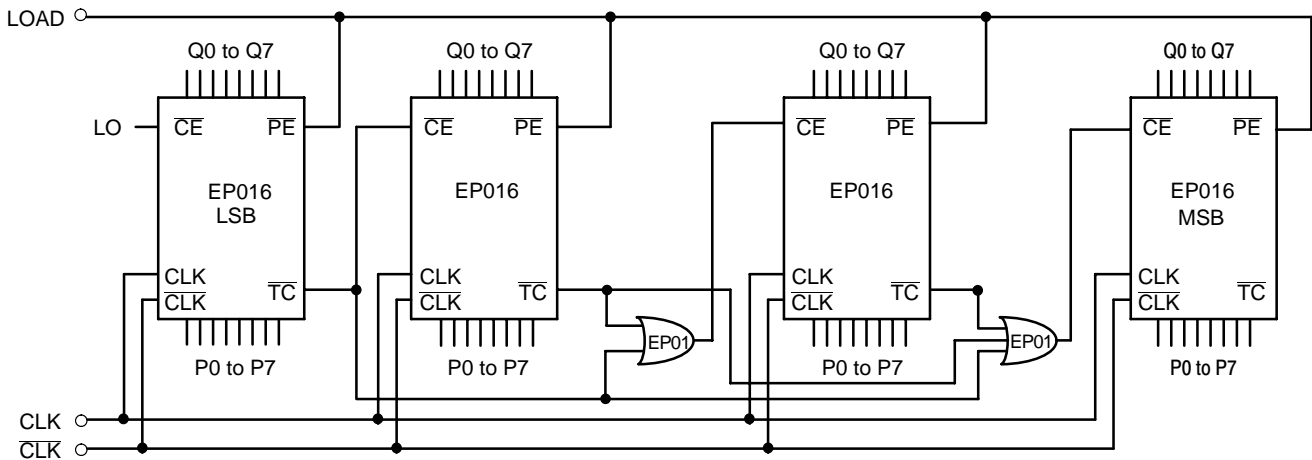

Figure 3. 32-Bit Cascaded EP016A Counter

Note that this assumes the trace delay between the  $\overline{TC}$  outputs and the  $\overline{CE}$  inputs are negligible. If this is not the case estimates of these delays need to be added to the calculations.

Programmable Divider

The EP016A has been designed with a control pin which makes it ideal for use as an 8-bit programmable divider. The

TCLD pin (load on terminal count) when asserted reloads the data present at the parallel input pin (Pn's) upon reaching terminal count (an all 1s state on the outputs). Because this feedback is built internal to the chip, the programmable division operation will run at very nearly the same frequency as the maximum counting frequency of the device. Figure 4 below illustrates the input conditions necessary for utilizing the EP016A as a programmable divider set up to divide by 113.

Applications Information (continued)

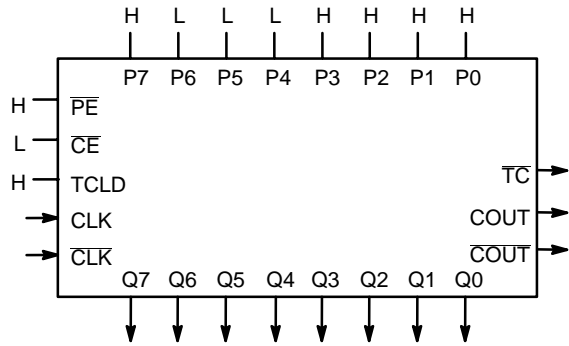

Figure 4. Mod 2 to 256 Programmable Divider

To determine what value to load into the device to accomplish the desired division, the designer simply subtracts the binary equivalent of the desired divide ratio from the binary value for 256. As an example for a divide ratio of 113:

$$Pn's = 256 - 113 = 8F_{16} = 1000\ 1111$$

where:

$$P0 = \text{LSB and } P7 = \text{MSB}$$

Forcing this input condition as per the setup in Figure 4 will result in the waveforms of Figure 5. Note that the  $\overline{TC}$  output is used as the divide output and the pulse duration is equal to a full clock period. For even divide ratios, twice the desired divide ratio can be loaded into the EP016A and the  $\overline{TC}$  output can feed the clock input of a toggle flip flop to create a signal divided as desired with a 50% duty cycle.

Table 1. Preset Values for Various Divide Ratios

| Divide Ratio | Preset Data Inputs |    |    |    |    |    |    |    |
|--------------|--------------------|----|----|----|----|----|----|----|
|              | P7                 | P6 | P5 | P4 | P3 | P2 | P1 | P0 |
| 2            | H                  | H  | H  | H  | H  | H  | H  | L  |
| 3            | H                  | H  | H  | H  | H  | H  | L  | H  |
| 4            | H                  | H  | H  | H  | H  | H  | L  | L  |
| 5            | H                  | H  | H  | H  | H  | L  | H  | H  |
| •            | •                  | •  | •  | •  | •  | •  | •  | •  |
| •            | •                  | •  | •  | •  | •  | •  | •  | •  |
| 112          | H                  | L  | L  | H  | L  | L  | L  | L  |
| 113          | H                  | L  | L  | L  | H  | H  | H  | H  |
| 114          | H                  | L  | L  | L  | H  | H  | H  | L  |
| •            | •                  | •  | •  | •  | •  | •  | •  | •  |
| •            | •                  | •  | •  | •  | •  | •  | •  | •  |
| 254          | L                  | L  | L  | L  | L  | L  | H  | L  |
| 255          | L                  | L  | L  | L  | L  | L  | L  | H  |
| 256          | L                  | L  | L  | L  | L  | L  | L  | L  |

A single EP016A can be used to divide by any ratio from 2 to 256 inclusive. If divide ratios of greater than 256 are needed multiple EP016As can be cascaded in a manner similar to that already discussed. When EP016As are cascaded to build larger dividers the TCLD pin will no longer provide a means for loading on terminal count. Because one does not want to reload the counters until all of the devices in the chain have reached terminal count, external gating of the  $\overline{TC}$  pins must be used for multiple EP016A divider chains.

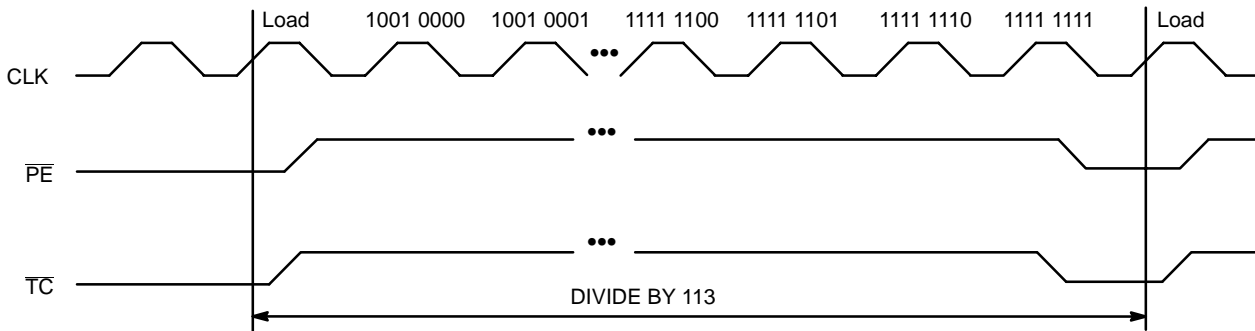

Figure 5. Divide by 113 EP016A Programmable Divider Waveforms



Applications Information (continued)

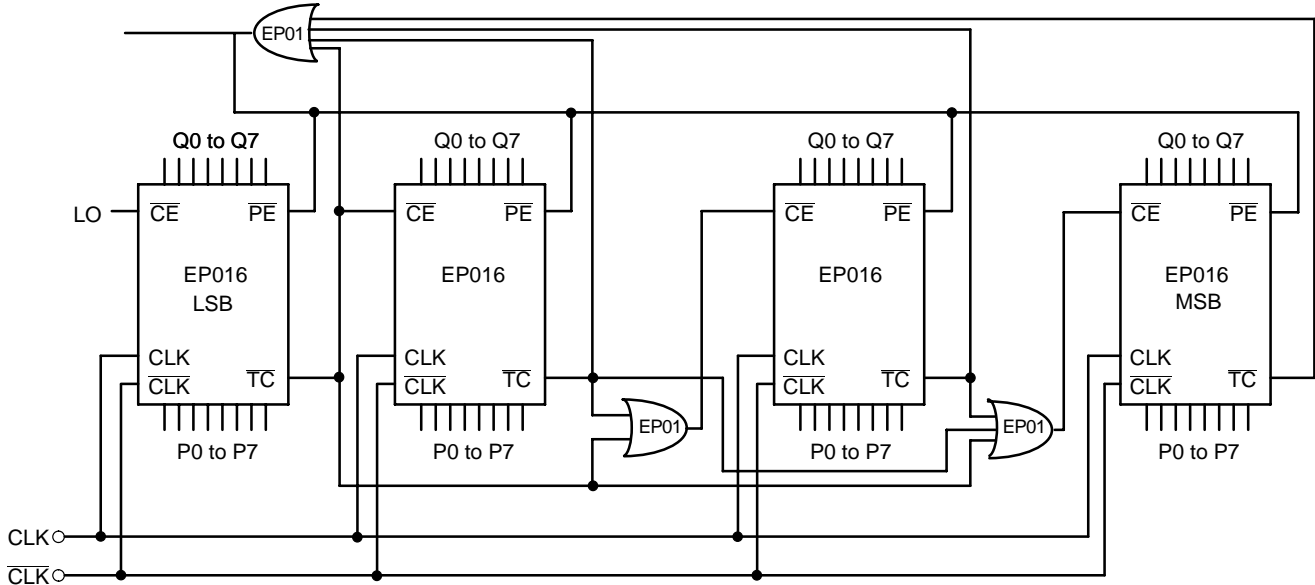

Figure 6. 32-Bit Cascaded EP016A Programmable Divider

Figure 6 shows a typical block diagram of a 32-bit divider chain. Once again to maximize the frequency of operation EP01 OR gates were used. For lower frequency applications a slower OR gate could replace the EP01. Note that for a 16-bit divider the OR function feeding the  $\overline{PE}$  (program enable) input CANNOT be replaced by a wire OR tie as the  $\overline{TC}$  output of the least significant EP016A must also feed the  $\overline{CE}$  input of the most significant EP016A. If the two  $\overline{TC}$  outputs were OR tied the cascaded count operation would not operate properly. Because in the cascaded form the  $\overline{PE}$  feedback is external and requires external gating, the maximum frequency of operation will be significantly less than the same operation in a single device.

**Maximizing EP016A Count Frequency**

The EP016A device produces 9 fast transitioning single ended outputs, thus  $V_{CC}$  noise can become significant in situations where all of the outputs switch simultaneously in the same direction. This  $V_{CC}$  noise can negatively impact the maximum frequency of operation of the device. Since the device does not need to have the Q outputs terminated to count properly, it is recommended that if the outputs are not going to be used in the rest of the system they should be left unterminated. In addition, if only a subset of the Q outputs are used in the system only those outputs should be terminated. Not terminating the unused outputs will not only cut down the  $V_{CC}$  noise generated but will also save in total system power dissipation. Following these guidelines will allow designers to either be more aggressive in their designs or provide them with an extra margin to the published data book specifications.

## MC100EP016A

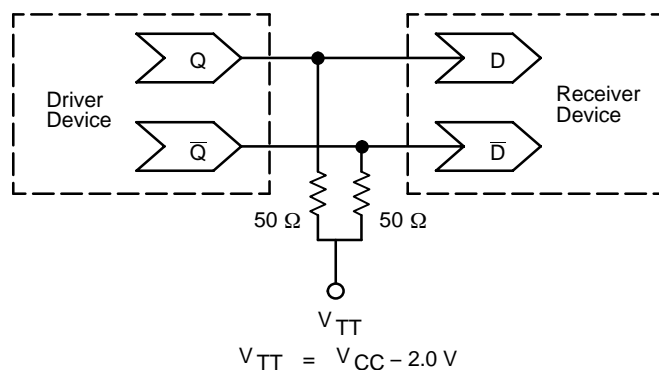

**Figure 7. Typical Termination for Output Driver and Device Evaluation  
(See Application Note AND8020 – Termination of ECL Logic Devices.)**

### Resource Reference of Application Notes

- AN1404** – ECLinPS Circuit Performance at Non-Standard  $V_{IH}$  Levels
- AN1405** – ECL Clock Distribution Techniques
- AN1406** – Designing with PECL (ECL at +5.0 V)
- AN1504** – Metastability and the ECLinPS Family
- AN1568** – Interfacing Between LVDS and ECL
- AN1650** – Using Wire-OR Ties in ECLinPS Designs
- AN1672** – The ECL Translator Guide
- AND8001** – Odd Number Counters Design
- AND8002** – Marking and Date Codes
- AND8009** – ECLinPS Plus Spice I/O Model Kit
- AND8020** – Termination of ECL Logic Devices

For an updated list of Application Notes, please see our website at <http://onsemi.com>.

# MC100EP016A

## PACKAGE DIMENSIONS

LQFP  
FA SUFFIX  
32-LEAD PLASTIC PACKAGE  
CASE 873A-02  
ISSUE B

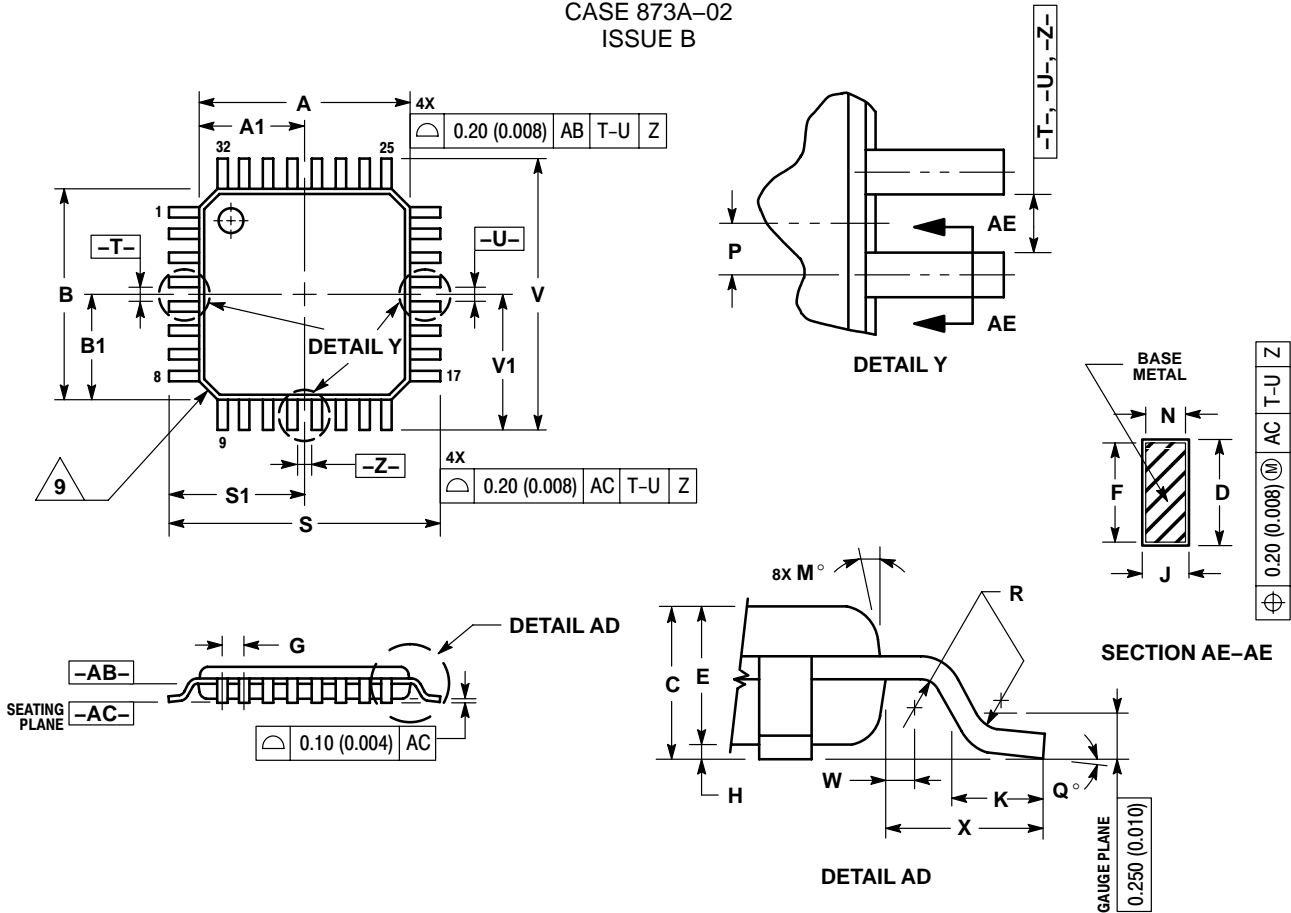

### NOTES:

- DIMENSIONING AND TOLERANCING PER ANSI Y14.5M, 1982.
- CONTROLLING DIMENSION: MILLIMETER.
- DATUM PLANE -AB- IS LOCATED AT BOTTOM OF LEAD AND IS COINCIDENT WITH THE LEAD WHERE THE LEAD EXITS THE PLASTIC BODY AT THE BOTTOM OF THE PARTING LINE.
- DATUMS -T-, -U-, AND -Z- TO BE DETERMINED AT DATUM PLANE -AB-.
- DIMENSIONS S AND V TO BE DETERMINED AT SEATING PLANE -AC-.
- DIMENSIONS A AND B DO NOT INCLUDE MOLD PROTRUSION. ALLOWABLE PROTRUSION IS 0.250 (0.010) PER SIDE. DIMENSIONS A AND B DO INCLUDE MOLD MISMATCH AND ARE DETERMINED AT DATUM PLANE -AB-.
- DIMENSION D DOES NOT INCLUDE DAMBAR PROTRUSION. DAMBAR PROTRUSION SHALL NOT CAUSE THE D DIMENSION TO EXCEED 0.520 (0.020).
- MINIMUM SOLDER PLATE THICKNESS SHALL BE 0.0076 (0.0003).
- EXACT SHAPE OF EACH CORNER MAY VARY FROM DEPICTION.

| DIM | MILLIMETERS |       | INCHES |       |
|-----|-------------|-------|--------|-------|
|     | MIN         | MAX   | MIN    | MAX   |
| A   | 7.000       | BSC   | 0.276  | BSC   |
| A1  | 3.500       | BSC   | 0.138  | BSC   |
| B   | 7.000       | BSC   | 0.276  | BSC   |
| B1  | 3.500       | BSC   | 0.138  | BSC   |
| C   | 1.400       | 1.600 | 0.055  | 0.063 |
| D   | 0.300       | 0.450 | 0.012  | 0.018 |
| E   | 1.350       | 1.450 | 0.053  | 0.057 |
| F   | 0.300       | 0.400 | 0.012  | 0.016 |
| G   | 0.800       | BSC   | 0.031  | BSC   |
| H   | 0.050       | 0.150 | 0.002  | 0.006 |
| J   | 0.090       | 0.200 | 0.004  | 0.008 |
| K   | 0.500       | 0.700 | 0.020  | 0.028 |
| M   | 12°         | REF   | 12°    | REF   |
| N   | 0.090       | 0.160 | 0.004  | 0.006 |
| P   | 0.400       | BSC   | 0.016  | BSC   |
| Q   | 1°          | 5°    | 1°     | 5°    |
| R   | 0.150       | 0.250 | 0.006  | 0.010 |
| S   | 9.000       | BSC   | 0.354  | BSC   |
| S1  | 4.500       | BSC   | 0.177  | BSC   |
| V   | 9.000       | BSC   | 0.354  | BSC   |
| V1  | 4.500       | BSC   | 0.177  | BSC   |
| W   | 0.200       | REF   | 0.008  | REF   |
| X   | 1.000       | REF   | 0.039  | REF   |

# MC100EP016A

ECLinPS is a trademark of Semiconductor Components Industries, LLC.

**ON Semiconductor** and  are registered trademarks of Semiconductor Components Industries, LLC (SCILLC). SCILLC reserves the right to make changes without further notice to any products herein. SCILLC makes no warranty, representation or guarantee regarding the suitability of its products for any particular purpose, nor does SCILLC assume any liability arising out of the application or use of any product or circuit, and specifically disclaims any and all liability, including without limitation special, consequential or incidental damages. "Typical" parameters which may be provided in SCILLC data sheets and/or specifications can and do vary in different applications and actual performance may vary over time. All operating parameters, including "Typicals" must be validated for each customer application by customer's technical experts. SCILLC does not convey any license under its patent rights nor the rights of others. SCILLC products are not designed, intended, or authorized for use as components in systems intended for surgical implant into the body, or other applications intended to support or sustain life, or for any other application in which the failure of the SCILLC product could create a situation where personal injury or death may occur. Should Buyer purchase or use SCILLC products for any such unintended or unauthorized application, Buyer shall indemnify and hold SCILLC and its officers, employees, subsidiaries, affiliates, and distributors harmless against all claims, costs, damages, and expenses, and reasonable attorney fees arising out of, directly or indirectly, any claim of personal injury or death associated with such unintended or unauthorized use, even if such claim alleges that SCILLC was negligent regarding the design or manufacture of the part. SCILLC is an Equal Opportunity/Affirmative Action Employer. This literature is subject to all applicable copyright laws and is not for resale in any manner.

## PUBLICATION ORDERING INFORMATION

### LITERATURE FULFILLMENT:

Literature Distribution Center for ON Semiconductor  
P.O. Box 5163, Denver, Colorado 80217 USA

**Phone:** 303-675-2175 or 800-344-3860 Toll Free USA/Canada

**Fax:** 303-675-2176 or 800-344-3867 Toll Free USA/Canada

**Email:** [orderlit@onsemi.com](mailto:orderlit@onsemi.com)

**N. American Technical Support:** 800-282-9855 Toll Free  
USA/Canada

**Japan:** ON Semiconductor, Japan Customer Focus Center  
2-9-1 Kamimeguro, Meguro-ku, Tokyo, Japan 153-0051  
**Phone:** 81-3-5773-3850

**ON Semiconductor Website:** <http://onsemi.com>

**Order Literature:** <http://www.onsemi.com/litorder>

For additional information, please contact your  
local Sales Representative.

**MC100EP016A/D**