

HD29029

Dual CCD Drivers

The HD29029 is optimum for CCD drive and has two drivers in a package. The input circuit is operated at TTL level. The outputs are capable of source or sink currents of 0.5 A.

Features

- High-speed operation 7 ns typ in transition times (t_{TLH} , t_{THL}) at $C_L = 200$ pF
- No external components needed because direct drive is available at TTL level inputs
- Output swing voltage : 12 V
Sink / Source currents : 0.5 A (for each)
- Output cross voltage : 50 % typ.

Pin Arrangement

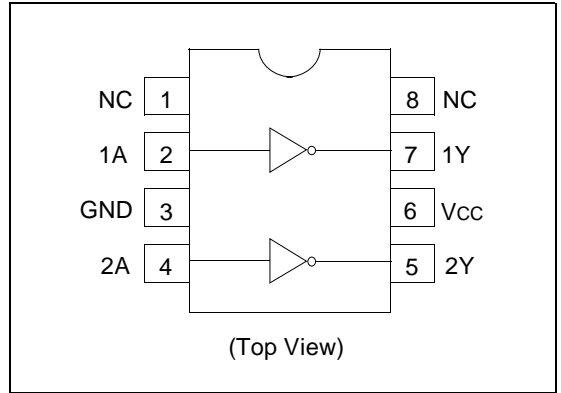

Function Table

Input A	Output Y
H	L
L	H

H : High level

L : Low level

Absolute Maximum Ratings

Item	Symbol	Ratings	Unit
Supply Voltage	V _{CC} *1	15	V
Input Voltage	V _{IN}	7	V
Output Current	I _o (peak)	±0.5	A
Operating Temperature	T _a	-20 to +75	°C
Storage Temperature	T _{stg}	-65 to +150	°C
Junction Temperature	T _j	150	°C
Power Dissipation per Package	P _T *2	DP-8	1
		FP-8	0.735

- Notes:
1. The voltage value is defined with respect to ground terminal unless otherwise noted.
 2. The total power dissipation is at T_a = 25°C. When driving large capacity with high frequency radiation is needed. There fore, delating with 8mW/°C (DP-8) or 5.9 mW/°C(FP-8) must be done as shown below.
 3. The absolute maximum ratings are values which must not individually be exceeded, and furthermore, no two of which may be realized at same time.

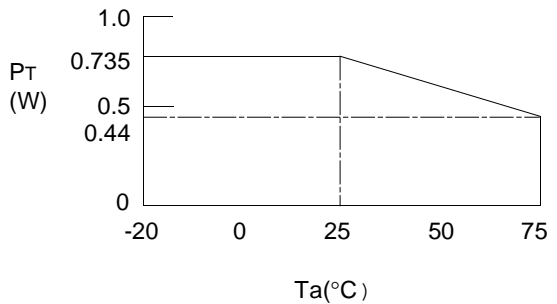
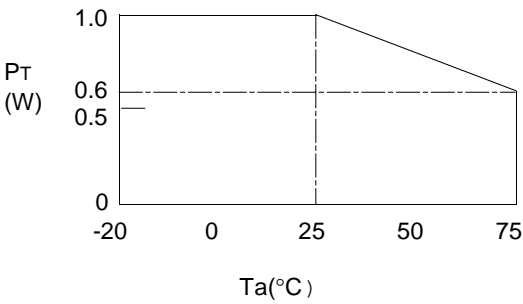

Recommended Operating Conditions

Item	Symbol	Min	Typ	Max	Unit
Supply Voltage	V _{CC}	8.0	9.0	13.0	V
Operating Temperature	T _a	-20	25	75	°C

Electrical Characteristics (V_{CC} = 8 to 13 V, T_a = -20 to 75 °C)

Item	Symbol	Min	Typ	Max	Unit	Conditions
Input Voltage	V _{IH}	2.0	—	—	V	
	V _{IL}	—	—	0.6	V	
Output Voltage	V _{OH}	V _{CC} -1	—	—	V	V _{IL} = 0.6 V, I _{OH} = -1 mA
	V _{OL}	—	—	0.5	V	V _{IH} = 2.0 V, I _{OL} = 1 mA
Input Current	I _{IH}	—	—	20	μA	V _I = 2.7 V
	I _{IL}	—	—	-100	μA	V _I = 0.4 V
Supply Current	I _{CCH}	—	—	10	mA	
	I _{CCL}	—	—	25	mA	
Input Current	I _I	—	—	100	μA	V _I = 7 V
Input Clamp Voltage	V _{IK}	—	—	-1.5	V	I _{IIN} = -18 mA

Switching Characteristics (C_L = 200 pF, T_a = 25 °C)

Item	Symbol	Min	Typ	Max	Unit	Conditions
Propagation Delay Time	t _{PHL}	—	4.0	15.0	ns	V _{CC} = 9 V
		—	4.0	13.0	ns	V _{CC} = 12 V
	t _{PLH}	—	6.0	15.0	ns	V _{CC} = 9 V
		—	6.0	13.0	ns	V _{CC} = 12 V
Transition Time	t _{THL}	—	8.0	14.0	ns	V _{CC} = 9 V
		—	7.0	12.0	ns	V _{CC} = 12 V
	t _{TLH}	—	8.0	14.0	ns	V _{CC} = 9 V
		—	7.0	12.0	ns	V _{CC} = 12 V

Switching Time Test Method

Test circuit

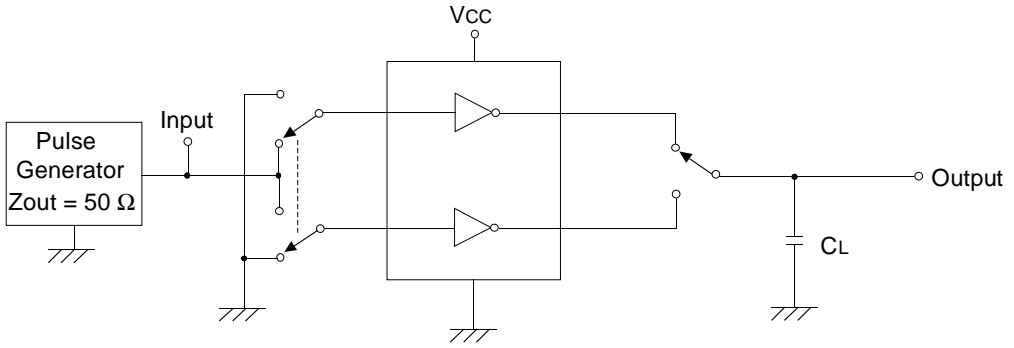

Note: 1. C_L includes probe and jig capacitance.

Waveforms

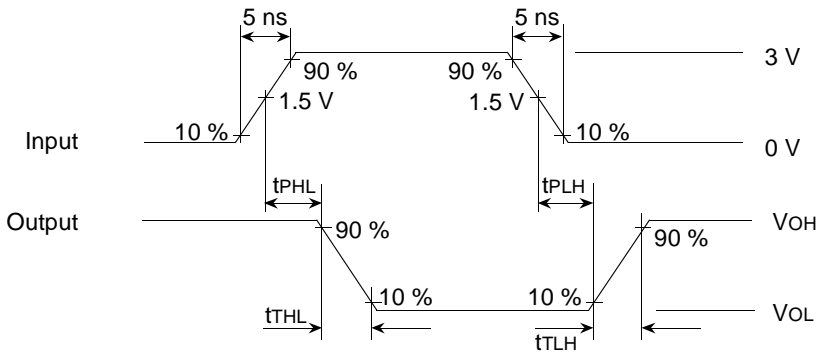

Note: 1. Input Waveforms : $f = 1 \text{ MHz}$, duty cycle 50 %

Output Characteristics (CL = 200 pF, Ta = 25°C)

Item	Symbol	Min	Typ	Max	Unit	Conditions
Output Cross Voltage	Vx	20	50	80	%	Vcc = 9 V
		20	50	80	%	Vcc = 12 V

Test circuit

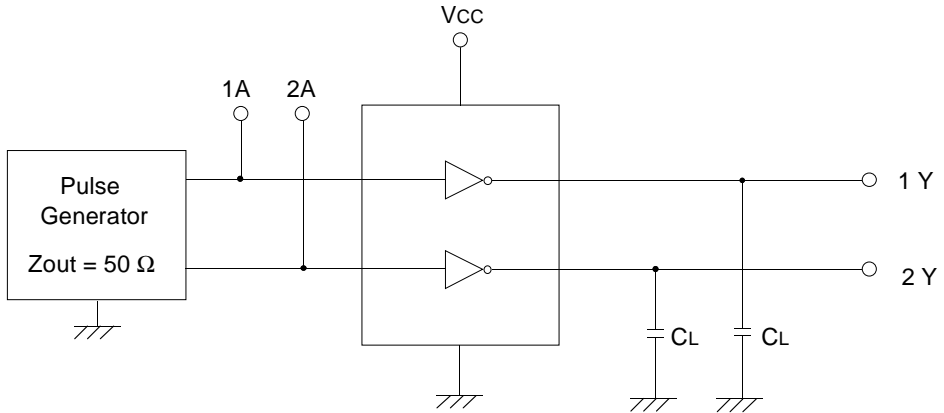

Note: 1. CL includes probe and jig capacitance.

Waveforms

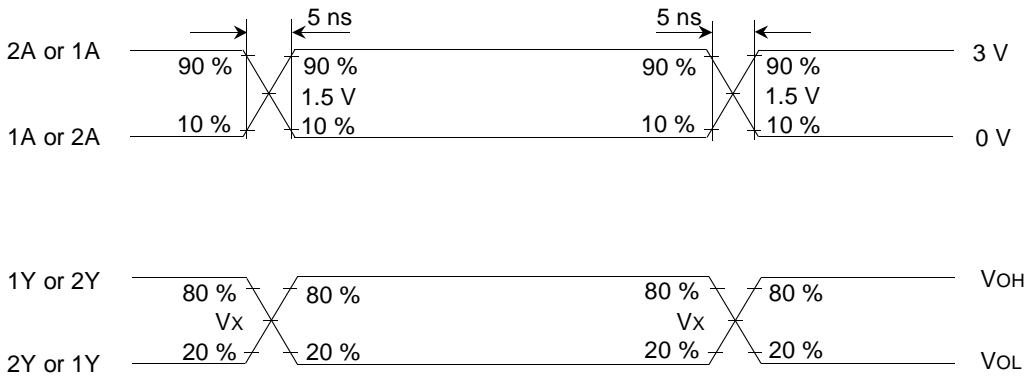

Note: 1. Input Waveforms : f = 1 MHz, duty cycle 50 %