



## **Aluminum electrolytic capacitors**

For automotive applications,  
single-ended, 105 °C / 3000 h

**Series/Type:**      **B41853**  
**Date:**              July 2005

# Single-ended Aluminum electrolytic capacitors



## Introduction

Aluminum electrolytic capacitors from EPCOS are constantly being enhanced to specifications meeting the typical requirements in the automotive industry. This section presents the latest innovations within the single-ended product line. All existing series have been improved and new series introduced. In addition, special lead configurations have been added to provide a broad range of lead options. The Protection Against Polarity Reversal (PAPR) concept has been extended with J leads and bent 90° leads. Blister packaging is now introduced as standard for all PAPR

configurations. This results in better quality and convenience for the customer.

The new B41853 series was developed to achieve excellent performance in airbag applications, covering a wide range of capacitance values up to 6800  $\mu\text{F}$ .

The high-reliability series B41868 for high temperatures up to 150 °C and the new B41896 series with long useful life for temperatures up to 125 °C take full advantage of higher ripple current capability in compact can sizes, ensuring exceptional performance in powertrain applications and control units installed in the vicinity of the engine.

The B41888 series has also been upgraded and provides very long useful life and high ripple current capability at 105 °C.

The B43866 series combines high temperature resistance up to 125 °C, at high operating voltages up to 350 V, and is a potential solution for new applications such as piezo injector technology.

EPCOS quality is certified by the international standards ISO 9001 and ISO/TS 16949. In addition, the introduction of new mechanical and technical features makes EPCOS single-ended aluminum electrolytic capacitors one of the best and most competitive products worldwide.

Standard type



J lead



Crimped lead



Bent 90° lead



Different lead configurations available. For more details see pages 63–66.



# Data sheet

## B41853

Specifications and characteristics in brief		
Rated voltage $V_R$	25 ... 50 VDC	
Surge voltage $V_{surge}$	$1.15 \cdot V_R$	
Rated capacitance $C_R$	470 ... 6800 $\mu$ F	
Capacitance tolerance	+20% $\cong$ M	
Useful life 105 °C; $V_R$ ; $I_{-R}$	3 000 h	Requirements: $\Delta C/C \leq \pm 35\%$ of initial measured value $\tan \delta \leq 3$ times initial specified value $I_{leak} \leq$ initial specified value
Voltage endurance test 105 °C; $V_R$	3 000 h	Post test requirements: $\Delta C/C \leq \pm 25\%$ of initial measured value $\tan \delta \leq 2$ times initial specified value $I_{leak} \leq$ initial specified value
Vibration resistance	To IEC 60068-2-6, test Fc: displacement amplitude 0.75 mm, frequency range 10 ... 2000 Hz, acceleration max. 20 g, duration 3 x 2 h (body clipping)	
IEC climatic category	To IEC 60068-1: 55/105/56 (- 55 °C/+105 °C/56 days damp heat test)	
Sectional specification	AEC-Q200, IEC 60384-4, DIN 45910 part 12	

### Features

- Designed to specifications typical of airbag applications
- Very low ESR
- Wide capacitance range up to 6800  $\mu$ F
- High ripple current capability
- Compact design
- Shelf life of the capacitor up to 15 years at storage temperatures up to 40 °C. To ensure solderability, the capacitors should be built into the application within one year of delivery. After a total of two years' storage, the operating voltage must be applied for one hour to ensure the specified leakage current.

Dimensional drawing, standard type	Dimensions and weights, standard type				
	$d \times l$ (mm)	$d_{max} \times l_{max}$ (mm)	a (mm)	$\varnothing b$ (mm)	Approx. weight (g)
	10 x 20	10.5 x 22	5.0	$0.60 \pm 0.05$	2.6
	12.5 x 20	13.0 x 22	5.0	$0.60 \pm 0.05$	3.6
	16 x 20	16.5 x 22	7.5	$0.80 \pm 0.05$	5.5
	18 x 20	18.5 x 22	7.5	$0.80 \pm 0.1$	8.0
	18 x 25	18.5 x 27	7.5	$0.80 \pm 0.1$	9.5
	18 x 31.5	18.5 x 32.5	7.5	$0.80 \pm 0.1$	11
	18 x 35	18.5 x 37	7.5	$0.80 \pm 0.1$	13
	18 x 40	18.5 x 42	7.5	$0.80 \pm 0.1$	16
	20 x 25	20.5 x 27	10.0	$0.80 \pm 0.1$	12

# Data sheet

## B41853



### Case dimensions and ordering codes

$V_R$ VDC	$C_R$ 120 Hz 20 °C μF	Case dimensions d x l mm	$\tan \delta_{\max}$ 120 Hz 20 °C	$ESR_{\max}$ 120 Hz 20 °C Ω	$I_{\sim R}$ 100 kHz 105 °C mA	$I_{\text{leak, max}}$ 5 min. 20 °C μA	Ordering code
25	1000	10 x 20	0.16	0.21	1200	250	B41853W5108M***
	2200	16 x 20	0.18	0.11	2000	550	B41853W5228M***
	2700	18 x 20	0.18	0.09	2500	675	B41853W5278M***
	3300	18 x 25	0.20	0.08	3400	825	B41853W5338M***
	4700	18 x 31.5	0.22	0.06	3600	1175	B41853W5478M***
	5600	18 x 35	0.24	0.05	4100	1400	B41853W5568M***
	6800	18 x 40	0.26	0.04	5100	1700	B41853W5688M***
35	470	10 x 20	0.14	0.39	1100	165	B41853W7477M***
	1000	12.5 x 20	0.14	0.18	1600	350	B41853W7108M***
	2200	18 x 20	0.16	0.09	2800	770	B41853W7228M***
	3300	18 x 31.5	0.18	0.07	3200	1150	B41853W7338M***
	4700	18 x 35	0.20	0.05	3700	1640	B41853W7478M***
	5600	18 x 40	0.22	0.04	4200	1900	B41853W7568M***
50	470	12.5 x 20	0.12	0.33	1170	250	B41853W6477M***
	680	16 x 20	0.12	0.23	1350	355	B41853W6687M***
	1000	18 x 20	0.12	0.16	1850	515	B41853W6108M***
	2200	20 x 25	0.12	0.08	2950	1115	B41853W6228M***

- \*\*\* = "000" for standard leads, bulk  
 "001" for kinked leads, bulk (for  $\varnothing \geq 10$  mm)  
 "002" for cut leads, bulk (for  $\varnothing \geq 10$  mm)  
 "003" for crimped leads, blister (for  $\varnothing \geq 16$  mm)  
 "004" for J leads, blister (from  $\varnothing 10 \times 12.5$  mm to  $18 \times 35$  mm)  
 "008" for taped leads, Ammo pack, lead spacing F = 5.0 mm (from  $\varnothing 6.3 \times 11$  mm to  $12.5 \times 25$  mm)  
 "009" for taped leads, Ammo pack, lead spacing F = 7.5 mm (from  $\varnothing 16 \times 20$  mm to  $18 \times 31.5$  mm)  
 "012" for bent 90° leads, blister (for  $\varnothing 16$  mm and 18 mm)

For more details refer to page 63 "Overview of packing units".

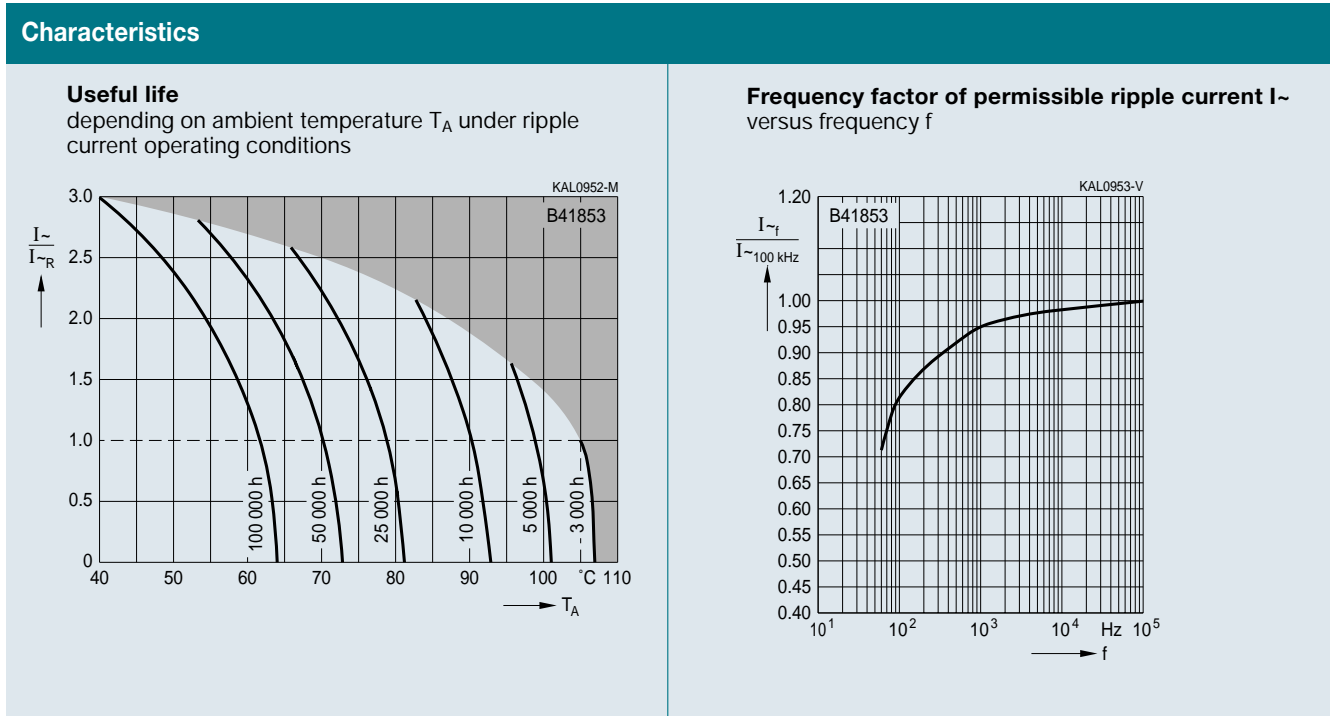

# Single-ended Aluminum electrolytic capacitors



## Overview of packing units

Case dimensions d x l (mm)	Standard, bulk (pcs.)	Taped, Ammo pack (pcs.)	Kinked leads, bulk (pcs.)	Cut leads, bulk (pcs.)	PAPR		
					Crimped leads, blister (pcs.)	J leads, blister (pcs.)	Bent 90° leads, blister (pcs.)
6.3 x 11	2500	2000	–	–	–	–	–
8 x 11.5	1000	1000	–	–	–	–	–
10 x 12.5	1000	750	–	1000	–	675	–
10 x 16	1000	500	–	1000	–	675	–
10 x 20	500	500	500	500	–	450	–
12.5 x 20	350	500	500	500	–	300	–
12.5 x 25	250	500	500	500	–	225	–
16 x 20	250	300	200	200	200	200	120
16 x 25	250	300	200	200	200	200	120
16 x 31.5	200	300	250	250	150	150	120
18 x 20	175	250	175	175	200	200	120
18 x 25	150	250	150	150	200	200	120
18 x 31.5	100	250	100	100	150	150	120
18 x 35	100	–	100	100	150	150	72
18 x 40	125	–	100	100	120	–	72
20 x 20	125	–	125	125	200	–	–
20 x 25	125	–	125	125	200	–	–
20 x 40	100	–	200	200	120	–	–
The last three digits of the complete ordering code state the lead configuration.	<b>000</b>	<b>008</b> (F = 5.0 mm, Ø 6.3 ... 12.5 mm) <b>009</b> (F = 7.5 mm, Ø 16 ... 18 mm)	<b>001</b>	<b>002</b>	<b>003</b>	<b>004</b>	<b>012</b>

Ordering code example: B41888W6227M**003** = crimped leads, blister

## Lead configurations

Standard leads	Dimensions (mm)			
	d x l	d <sub>max</sub> x l <sub>max</sub>	a	∅ b
	6.3 x 11	6.8 x 12	2.5	0.50 ± 0.05
	8 x 11.5	8.5 x 13	3.5	0.60 ± 0.05
	10 x 12.5	10.5 x 13.5	5.0	0.60 ± 0.05
	10 x 16	10.5 x 17	5.0	0.60 ± 0.05
	10 x 20	10.5 x 22	5.0	0.60 ± 0.05
	12.5 x 20	13.0 x 22	5.0	0.60 ± 0.05
	12.5 x 25	13.0 x 27	5.0	0.60 ± 0.05
	16 x 20	16.5 x 22	7.5	0.80 ± 0.05
	16 x 25	16.5 x 27	7.5	0.80 ± 0.05
	16 x 31.5	16.5 x 33.5	7.5	0.80 ± 0.05
	18 x 20	18.5 x 22	7.5	0.80 ± 0.1
	18 x 25	18.5 x 27	7.5	0.80 ± 0.1
	18 x 31.5	18.5 x 32.5	7.5	0.80 ± 0.1
	18 x 35	18.5 x 37	7.5	0.80 ± 0.1
	18 x 40	18.5 x 42	7.5	0.80 ± 0.1
	20 x 20	20.5 x 22	10.0	0.80 ± 0.1
	20 x 25	20.5 x 27	10.0	0.80 ± 0.1
	20 x 40	20.5 x 42	10.0	0.80 ± 0.1

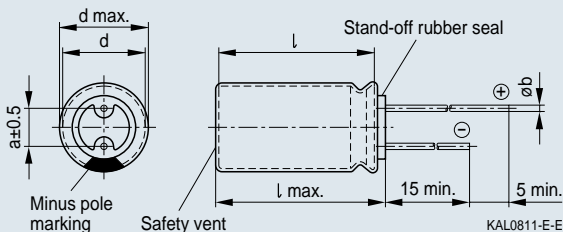



## Lead configurations

### Taped in Ammo pack, lead spacing $F = 5.0$ mm

$\varnothing d = 6.3 \dots 8$  mm

$\varnothing d = 10 \dots 12.5$  mm

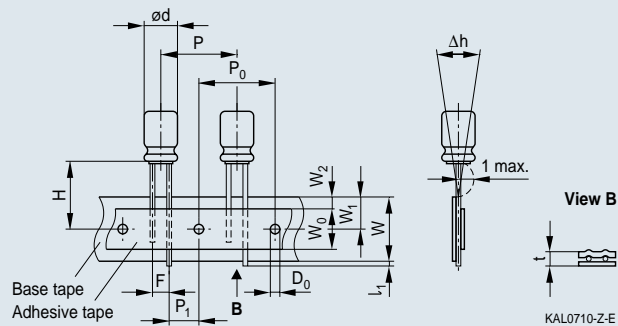
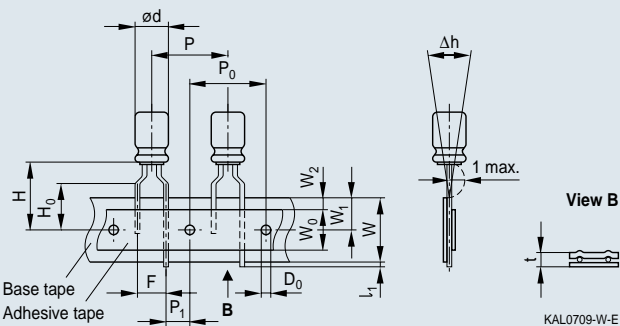

#### Dimensions (mm)

$\varnothing d$	F	H	H <sub>0</sub>	W	W <sub>0</sub>	W <sub>1</sub>	W <sub>2</sub>	P	P <sub>0</sub>	P <sub>1</sub>	l <sub>1</sub>	t	$\Delta h$	D <sub>0</sub>
6.3	5.0	18.5	16.0	18.0	5.5	9.0	1.5	12.7	12.7	3.85	1.0	0.7	0	4.0
8	5.0	20.0	16.0	18.0	12.5	9.0	1.5	12.7	12.7	3.85	1.0	0.7	0	4.0
10	5.0	19.0	-	18.0	12.5	9.0	1.5	12.7	12.7	3.85	1.0	0.7	0	4.0
12.5	5.0	19.0	-	18.0	12.5	9.0	1.5	15.0	15.0	5.0	1.0	0.7	0	4.0
Tolerance	+0.8 / -0.2	±0.75	±0.5	±0.5	min.	±0.5	max.	±1.0	±0.2	±0.5	max.	±0.2	±1.0	±0.2

### Taped in Ammo pack, lead spacing $F = 7.5$ mm

$\varnothing d = 16 \dots 18$  mm

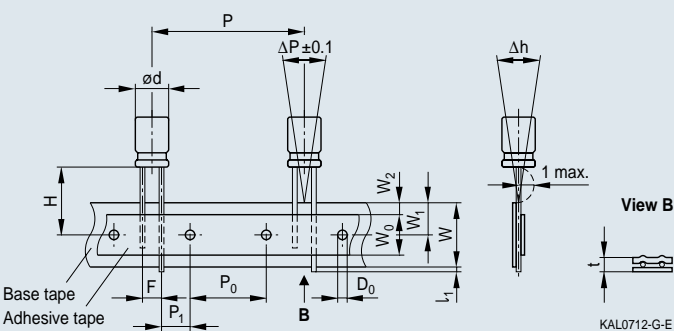

#### Dimensions (mm)

$\varnothing d$	F	H	W	W <sub>0</sub>	W <sub>1</sub>	W <sub>2</sub>	P	P <sub>0</sub>	P <sub>1</sub>	l <sub>1</sub>	t	$\Delta P$	$\Delta h$	D <sub>0</sub>
16	7.5	18.5	18.0	12.5	9.0	1.5	30.0	15.0	3.75	1.0	0.7	0	0	4.0
18 <sup>*)</sup>	7.5	18.5	18.0	12.5	9.0	1.5	30.0	15.0	3.75	1.0	0.7	0	0	4.0
Tolerance	±0.8	-0.5/+0.75	±0.5	min.	±0.5	max.	±1.0	±0.2	±0.5	max.	±0.2	±1.0	±1.0	±0.2

<sup>\*)</sup> Available only for case dimensions 18 x 20, 18 x 25 and 18 x 31.5 mm

# Lead configurations

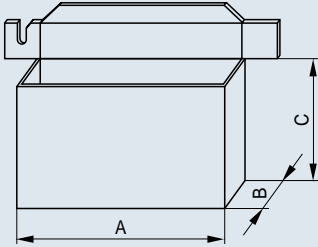

Ammo pack	Dimensions (mm)			
	$d \times l$	$A_{max}$	$B_{max}$	$C_{max}$
 <p>KAL0713-P</p>	6.3 x 11	345	55	290
	8 x 11.5	345	55	240
	10 x 12.5	345	55	280
	10 x 16	345	60	200
	10 x 20	345	60	200
	12.5 x 20	345	65	280
	12.5 x 25	345	65	280
	16 x 20	315	65	275
	16 x 25	315	65	275
	16 x 31.5	315	65	275
	18 x 20	315	65	275
	18 x 25	315	65	275
	18 x 31.5	315	65	275

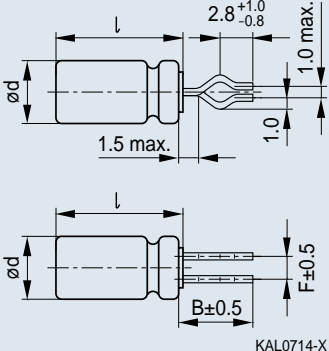
Kinked leads	Dimensions (mm)		
	$d \times l$	F	B
 <p>KAL0714-X</p>	10 x 20	5.0	4.5
	12.5 x 20	5.0	4.5
	12.5 x 25	5.0	4.5
	16 x 20	7.5	4.5
	16 x 25	7.5	4.5
	16 x 31.5	7.5	4.5
	18 x 20	7.5	4.5
	18 x 25	7.5	4.5
	18 x 31.5	7.5	4.5
	18 x 35	7.5	4.5
	18 x 40	7.5	4.5
	20 x 20	10.0	4.5
	20 x 25	10.0	4.5
	20 x 40	10.0	4.5

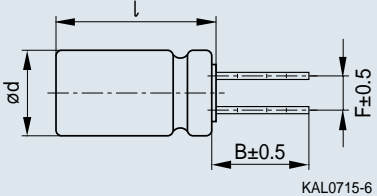
Cut leads	Dimensions (mm)		
	$d \times l$	F	B
 <p>KAL0715-6</p>	10 x 12.5	5.0	4.5
	10 x 16	5.0	4.5
	10 x 20	5.0	4.5
	12.5 x 20	5.0	4.5
	12.5 x 25	5.0	4.5
	16 x 20	7.5	4.5
	16 x 25	7.5	4.5
	16 x 31.5	7.5	4.5
	18 x 20	7.5	4.5
	18 x 25	7.5	4.5
	18 x 31.5	7.5	4.5
	18 x 35	7.5	4.5
	18 x 40	7.5	4.5
	20 x 20	10.0	4.5
20 x 25	10.0	4.5	
20 x 40	10.0	4.5	



## Lead configurations

### PAPR leads ( Protection Against Polarity Reversal )

These lead configurations ensure correct placement of the capacitors on the PCB with regard to polarity. PAPR leads are available for diameters from 10 mm up to 20 mm. There are three configurations available:

- Crimped leads
- J leads
- Bent 90° leads

Crimped leads	Dimensions (mm)						
	<b>d x l</b>	<b>B</b>	<b>C</b>	<b>D</b>	<b>E</b>	<b>a</b>	<b>b</b>
	16 x 20	1.5	3.0	1.3	0.3	7.5	0.8 ± 0.05
	16 x 25	1.5	3.0	1.3	0.3	7.5	0.8 ± 0.05
	16 x 31.5	1.5	3.0	1.3	0.3	7.5	0.8 ± 0.05
	18 x 20	1.5	3.0	1.3	0.3	7.5	0.8 ± 0.1
	18 x 25	1.5	3.0	1.3	0.3	7.5	0.8 ± 0.1
	18 x 31.5	1.5	3.0	1.3	0.3	7.5	0.8 ± 0.1
	18 x 35	1.5	3.0	1.3	0.3	7.5	0.8 ± 0.1
	18 x 40	1.5	3.0	1.3	0.3	7.5	0.8 ± 0.1
	20 x 20	1.5	3.0	1.3	0.3	10.0	0.8 ± 0.1
	20 x 25	1.5	3.0	1.3	0.3	10.0	0.8 ± 0.1
	20 x 40	1.5	3.0	1.3	0.3	10.0	0.8 ± 0.1

J leads	Dimensions (mm)					
	<b>d x l</b>	<b>B</b>	<b>E</b>	<b>J</b>	<b>a</b>	<b>Ø b</b>
	10 x 12.5	3.2	0.7	1.2	5.0	0.6 ± 0.05
	10 x 16	3.2	0.7	1.2	5.0	0.6 ± 0.05
	10 x 20	3.2	0.7	1.2	5.0	0.6 ± 0.05
	12.5 x 20	3.2	0.7	1.2	5.0	0.6 ± 0.05
	12.5 x 25	3.2	0.7	1.2	5.0	0.6 ± 0.05
	16 x 20	3.5	0.7	1.6	7.5	0.8 ± 0.05
	16 x 25	3.5	0.7	1.6	7.5	0.8 ± 0.05
	16 x 31.5	3.5	0.7	1.6	7.5	0.8 ± 0.05
	18 x 20	3.5	0.7	1.6	7.5	0.8 ± 0.1
	18 x 25	3.5	0.7	1.6	7.5	0.8 ± 0.1
	18 x 31.5	3.5	0.7	1.6	7.5	0.8 ± 0.1
18 x 35	3.5	0.7	1.6	7.5	0.8 ± 0.1	

Bent 90° leads for horizontal mounting pinning	Dimensions (mm)					
	<b>d x l</b>	<b>C</b>	<b>E</b>	<b>F</b>	<b>a</b>	<b>Ø b</b>
	16 x 20	4.0	4.0	12.0	7.5	0.8 ± 0.05
	16 x 25	4.0	4.0	12.0	7.5	0.8 ± 0.05
	16 x 31.5	4.0	4.0	12.0	7.5	0.8 ± 0.05
	18 x 20	4.0	3.0	13.0	7.5	0.8 ± 0.1
	18 x 25	4.0	3.0	13.0	7.5	0.8 ± 0.1
	18 x 31.5	4.0	3.0	13.0	7.5	0.8 ± 0.1
	18 x 35	4.0	3.0	13.0	7.5	0.8 ± 0.1
	18 x 40	4.0	3.0	13.0	7.5	0.8 ± 0.1



## Mounting considerations

The internal structure of single-ended capacitors might be damaged if excessive force is applied to the lead wires. Stresses like push, pull, bend, etc. might cause increased leakage current, intermittent capacitance, electrolyte leakage or open/short circuit, due to rupture of terminals or internal elements.

The following actions should be avoided:

- Moving the capacitor after soldering to the PC board.
- Picking up the PC board by holding the soldered capacitor.
- Inserting the capacitor on the PC board with a hole space different to the specified lead space.



### Example

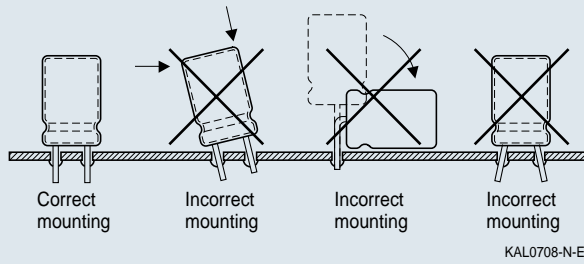

# Important notes

The following applies to all products named in this publication:

1. Some parts of this publication contain **statements about the suitability of our products for certain areas of application**. These statements are based on our knowledge of typical requirements that are often placed on our products in the areas of application concerned. We nevertheless expressly point out **that such statements cannot be regarded as binding statements about the suitability of our products for a particular customer application**. As a rule, EPCOS is either unfamiliar with individual customer applications or less familiar with them than the customers themselves. For these reasons, it is always ultimately incumbent on the customer to check and decide whether an EPCOS product with the properties described in the product specification is suitable for use in a particular customer application.
2. We also point out that **in individual cases, a malfunction of passive electronic components or failure before the end of their usual service life cannot be completely ruled out in the current state of the art, even if they are operated as specified**. In customer applica-

tions requiring a very high level of operational safety and especially in customer applications in which the malfunction or failure of a passive electronic component could endanger human life or health (e.g. in accident prevention or life-saving systems), it must therefore be ensured by means of suitable design of the customer application or other action taken by the customer (e.g. installation of protective circuitry or redundancy) that no injury or damage is sustained by third parties in the event of malfunction or failure of a passive electronic component.

3. **The warnings, cautions and product-specific notes must be observed.**
4. In order to satisfy certain technical requirements, **some of the products described in this publication may contain substances subject to restrictions in certain jurisdictions (e.g. "hazardous")**. Useful information on this will be found in our Material Data Sheets on the Internet ([www.epcos.com/material](http://www.epcos.com/material)). Should you have any more detailed questions, please contact our sales offices.
5. We constantly strive to improve our products. Consequently, **the products described in this**

**publication may change from time to time**. The same is true of the corresponding product specifications. Please check therefore to what extent product descriptions and specifications contained in this publication are still applicable before or when you place an order.

We also **reserve the right to discontinue production and delivery of products**. Consequently, we cannot guarantee that all products named in this publication will always be available.

6. Unless otherwise agreed in individual contracts, **all orders are subject to the current version of the "General Terms of Delivery for Products and Services in the Electrical Industry" published by the German Electrical and Electronics Industry Association (ZVEI)**.
7. The trade names EPCOS, CeraDiode, CSSP, SIMID, PhaseCap, PhaseMod, SIFI, SIKOREL, SilverCap, SiOV, SIP5D, SIP5K, TOPcap, UltraCap, WindCap are **trademarks registered or pending** in Europe and in other countries. Further information will be found on the Internet at [www.epcos.com/trademarks](http://www.epcos.com/trademarks).

# Cautions and warnings

## Personal safety

The electrolytes used by EPCOS have not only been optimized with a view to the intended application, but also with regard to health and environmental compatibility. They do not contain any solvents that are detrimental to health, e.g. dimethyl formamide (DMF) or dimethyl acetamide (DMAC).

Furthermore, part of the high-voltage electrolytes used by EPCOS are self-extinguishing. They contain flame-retarding substances which will quickly extinguish any flame that may have been ignited.

As far as possible, EPCOS does not use any dangerous chemicals or compounds to produce operating electrolytes. However, in exceptional cases, such materials must be used in order to achieve specific physical and electrical properties because no safe substitute materials are currently known. However, the amount of dangerous materials used in our products has been limited to an absolute minimum. Nevertheless, the following rules should be observed when handling Al electrolytic capacitors:

- Any escaping electrolyte should not come into contact with eyes or skin.
- If electrolyte does come into contact with the skin, wash the affected parts immediately with running water. If the eyes are affected, rinse them for 10 minutes with plenty of water. If symptoms persist, seek medical treatment.
- Avoid breathing in electrolyte vapor or mists. Workplaces and other affected areas should be well ventilated. Clothing that has been contaminated by electrolyte must be changed and rinsed in water.

## Product safety

- Make sure that polar capacitors are connected with the right polarity.
- Voltage polarity clashes should be prevented by connecting a diode.
- Do not damage the insulating sleeve, especially when ring clips are used for mounting.
- Do not exceed the upper category temperature (UCT).
- Make periodic inspections of the capacitors. Before the inspection, make sure that the power supply is turned off and carefully discharge the electricity of the capacitors.
- Do not apply any mechanical stress to the capacitor terminals.
- The internal structure of single-ended capacitors may be damaged if excessive force is applied to the lead wires.
- Avoid any compressive, tensile or flexural stress.
- Do not move the capacitor after soldering to the PC board.
- Do not pick up the PC board by the soldered capacitor.
- Do not insert the capacitor on the PC board with a hole space different to the lead space specified.
- Do not exceed the specified time or temperature limits during soldering.
- Capacitors should be dipped in solder for less than 10 seconds.
- Do not allow halogenated hydrocarbons to come into contact with aluminum electrolytic capacitors.
- Avoid external energy, such as fire or electricity.
- Avoid overload of the capacitors.

Failure to follow cautions and warnings may result in the worst case in premature failure, bursting and fire.

## Product safety

### Polarity

Make sure that polar capacitors are connected with the right polarity. If the opposite polarity were to be applied, this would cause an electrolytic process resulting in the formation of a dielectric layer on the cathode foil. In this case strong internal heat generation and gas emission may occur and destroy the capacitor. Polar capacitors do not tolerate a voltage reversal. Incorrect polarities of up to 1.5 V are, however, permissible for short periods of time as the formation of a damaging oxide layer on the cathode only starts at voltages of this magnitude.

### Reverse voltage

Aluminum electrolytic capacitors are polar capacitors. Where necessary, voltages of opposite polarity should be prevented by connecting a diode. The diode's conducting-state voltage of approximately 0.8 V is permissible. Reverse voltages  $\leq 1.5$  V are tolerable for a duration of less than 1 second, but not in continuous or repetitive operation.

### Breakdown strength of insulating sleeves

The minimum breakdown strength of the insulating sleeve is 2500 VAC or 3500 VDC. A test method for verifying the breakdown strength of the sleeves is described in IEC 60384-4. In order to ensure full breakdown strength, care must be taken not to damage the insulating sleeve, especially when ring clips are used for mounting. The insulation can be improved by using an insulating strip. In such cases, attention must be paid to any relevant regulations (e.g. VDE, BSA or UL regulations).

### Upper category temperature (UCT)

The upper category temperature is the maximum permissible ambient temperature at which a capacitor may be continuously operated. If this limit is exceeded, the capacitor may fail prematurely. For some type series, however, operation at temperatures above the UCT is permissible for short periods of time. The maximum permissible operating temperatures are specified in the data sheets for the individual type series under "Specifications

and characteristics in brief", section "Useful life".

### Maintenance

Make periodic inspections for the capacitors that have been used in the devices for industrial applications. Before the inspection, make that the power supply is turned off and carefully discharge the electricity of the capacitors. To check the capacitors, make sure of the polarity when measuring the capacitors by using a volt-ohm meter, for instance. Also, do not apply any mechanical stress to the capacitor terminals. The following items should be checked by the periodic inspections. Significant damage to appearances: venting, electrolyte leakage, etc. Electrical characteristics: leakage current, capacitance,  $\tan \delta$  and other characteristics prescribed in the catalogs or product specifications. If any of the above is found, replace it or take any other proper measure. Halogenated hydrocarbons may cause serious damage if allowed to come into contact with aluminum electrolytic capacitors.

### Mounting position

An overpressure vent ensures that the gas can escape when the pressure reaches a certain level. To prevent electrolyte from leaking out when the gas is "vented", the capacitor should be mounted in an upright position (90°). All of these mounting positions are intended to avoid a vent-down installation of the capacitor.

### Mounting of single-ended capacitors

For further information see page 67.

### Soldering

Excessive time or temperature during soldering will affect capacitor's characteristics and cause damage to the insulation sleeve. Capacitors should be dipped in solder for less than 10 seconds. Contact of the sleeve with soldering iron must be avoided.

### Soldering, cleaning agents

Halogenated hydrocarbons may cause serious damage if allowed to come into contact with aluminum

electrolytic capacitors. These solvents may dissolve or decompose the insulating film and reduce the insulating properties to below the permissible level. The capacitor seals may be affected and swell, and the solvents may even penetrate them. This will lead to premature component failure.

Because of this, measures must be taken to prevent electrolytic capacitors from coming into contact with the solvents when using halogenated hydrocarbon solvents to clean printed circuit boards after soldering the components, or to remove flux residues. If it is not possible to prevent the electrolytic capacitors from being wetted by the solvent, halogen-free solvents must be used in order to eliminate the possibility of damage.

### Passive flammability

Under the influence of high external energy, such as fire or electricity, the flammable parts may get inflamed. Clause 38 of the relevant specification CECC 30000 (Harmonized System of Quality Assessment for Electronic Components; Generic Specification: Fixed Capacitors) refers to IEC Publication 695-2-2 (Needle Flame Test) for testing the passive flammability of capacitors. And in CECC 30000, severities and requirements for different categories of flammability are listed. Most of aluminum electrolytic capacitors meet the requirements of category C.

### Active flammability

In rare cases the component may ignite caused by heavy overload or some capacitor defect. One reason could be the following: During the operation of an aluminum electrolytic capacitor with nonsolid electrolyte, there is a small quantity of hydrogen developed in the component. Under normal conditions, this gas permeates easily out of the capacitor. But under exceptional circumstances, higher gas amounts may develop and may catch fire if a sparking would occur at the same time. As explained above a fire risk can't be totally excluded. Therefore, it is recommended to use special measures in critical applications (e.g. additional encapsulation of the equipment for mining applications).