



GENERAL DESCRIPTOR

The eKM6611 is a transmitter (Tx) controller of RF mouse, which support the 3D, 5/3 buttons RF mouse. And it's built-in the battery detect function. The eKM6611 is to match with RF Mouse Rx controller for eKM6211 series (PS/2) or eKM6251 (USB+PS2).

FEATURE

- Operating voltage range: 2.2V~5.5V
- Available in temperature range: 0 ~70
- Operating frequency: 4.00Mhz
- Efficient encoding algorithm for RF data packets.
- Device ID
 - Power-on is default ID.
 - Using the push button to random generate the 255 sets ID.
- Support 2 different Z-axis type and mouse buttons
 - Mechanical-device type , 5 buttons (eKM6611A)
 - Photo-couple type, 3 buttons (eKM6611B)
- Support 3 Operation Mode to saving power.
 - Operation mode
 - Standby mode
 - Sleep mode
- To match with RF Mouse Rx controller :
 - eKM6211: PS/2 only
 - eKM6251: USB and PS/2
- Package type: 16 pins DIP and SOP (300mil)

APPLICATION

- 3D, 5 buttons RF mouse Tx with mechanical Z-axis.
- 3D, 3 buttons RF Mouse Tx with photo Z-axis.

PIN ASSIGNMENT

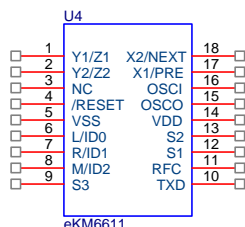

PIN DESCRIPTOR

	Symbol	I/O	Function
1	Y1	I	Y1/Z1 input pin
2	Y2	I	Y2/Z2 input pin
3	NC	-	N.C.
4	/RESET	I	Reset pin
5	VSS	-	Ground pin
6	L	I	L buttons
7	R	I	R buttons
8	M	I	M buttons
9	S3	I/O	S3 control line,
10	TXD	O	RF data output
11	RFC	O	RF module control. High active
12	S1	I/O	S1 control output
13	S2	I/O	S2 control output
14	VDD	-	Voltage supply pin
15	OSCO	O	Output for crystal oscillator clock.
16	OSCI	I	External crystal input
17	X1	I	X1 input, Pre button
18	X2	I	X2 input, Next button

FUNCTION DESCRIPTOR

There are two types of eKM6611 series : eKM6611A and eKM6611B. The Table 1.1



summarizes the features of each type in eKM6611 series.

No.	Osc. Freq.	Z axis type	XY scan rate	Buttons	comment
eKM6611A	4.00Mhz	Mechanica	10.0KHz	5	
eKM6611B	4.00Mhz	Photo	6.6KHz	3	2-diode z axis photo

1. Oscillator Frequency

The external oscillator frequency is 4.00MHz, it's have higher movement scan rate (up to 10KHz).

2. Device ID

When eKM6611 is power-on, it initial to default ID (0xFF), first. eKM6611 is using the connect button to generate a random ID. After the button is pushed and released, the controller will generate a new ID (from 0x01 to 0xFF) and transmit the new ID to the receiver consecutively at least 10sec. Each power on time, the Device ID will set to 0xFF automatically. Only when the conflict occurs, user is needs to set ID manually.

3. Z-axis type

The wheel of 3D mouse, which we used to call it Z-axis, it's detected by mechanical device or photo-couples. eKM6611_A, and eKM6611_B is support the latter. The noise immunity of photo-couples is better than the mechanical device. However, the photo-couples is more expensive.

4. Operation mode

The eKM6611 have three operation modes, that's Operating Mode, Standby Mode and Sleep Mode. While the mouse is moving, the controller is working under the Operating Mode, sending the data to RF module for transmitting. If the mouse stops over 0.5 seconds, the eKM6611 will enter the Standby mode to reduce the consumption of power. Once the movement is detected or buttons are pushed, the controller will return to Operating mode. After working under the Standby Mode for an interval, it will enter Sleep Mode automatically. In Sleep Mode, the controller saves at least 95% consumption of power in Operating Mode.

Test IC: eKM6611A

Oscillator: 4.00Mhz

Battery Voltage: 3.15V

	with RF module	without RF Module
Operating Mode:	10.2mA	6.7mA
Standby Mode	1.2mA	1.2mA
Sleep Mode	79μA	78μA

APPLICATION CIRCUIT

eKM6611_A

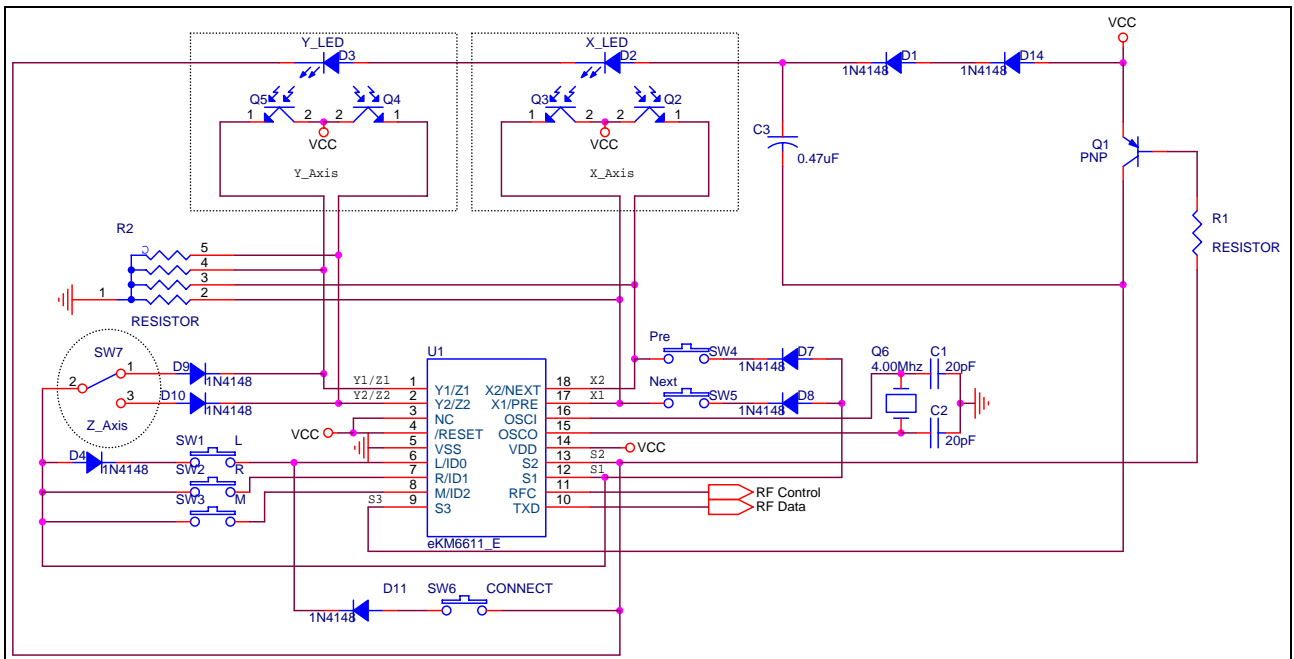

eKM6611_B

