

32 Megabit FLASH EEPROM

DP5Z1MW32PV3

DESCRIPTION:

The DP5Z1MW32PV3 "VERSA-STACK" module is a memory subsystem using DPAC Technologies' ceramic Stackable Leadless Chip Carriers (SLCC) mounted on a co-fired ceramic substrate. It offers 32 Megabits of FLASH EEPROM in a single package envelope of 1.090" x 1.090" x .163".

The DP5Z1MW32PV3 is built with 2 SLCC packages each containing 1Meg x 16 FLASH memory devices. Each SLCC is hermetically sealed, making the module suitable for commercial, industrial and military applications.

By using SLCCs, the "Versa-Stack" family of modules offers a higher board density of memory than available with conventional through-hole, surface mount, module or hybrid techniques.

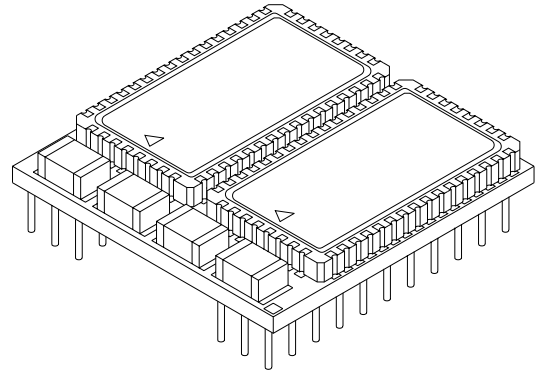

FEATURES:

- Organizations Available: 1 Meg x 32, 2 Meg x 16
- Fast Access Times: 120, 150, 200ns (max.)
- Single 5.0 Volt
- High-Density Symmetrically Blocked Architecture
 - Sixteen 128 Kbyte Blocks Per Device
- Extended Cycling Capability
 - 100K Write/Erase Cycles
- Automated Erase and Program Cycles
 - Command User Interface
 - Status Register
- SRAM-Compatible Write Interface
- Hardware Data Protection Feature
 - Erase / Write Lockout during Power Transitions
- 66 - Pin PGA "VERSA-STACK" Package

PIN NAMES	
A0 - A19	Address Inputs
I/O0 - I/O31	Data Input/Output
$\overline{CE}0, \overline{CE}1$	Chip Enables
\overline{WE}	Write Enables
\overline{OE}	Output Enables
V _{DD}	Power (+5 Volts)
V _{SS}	Ground
N.C.	No Connect

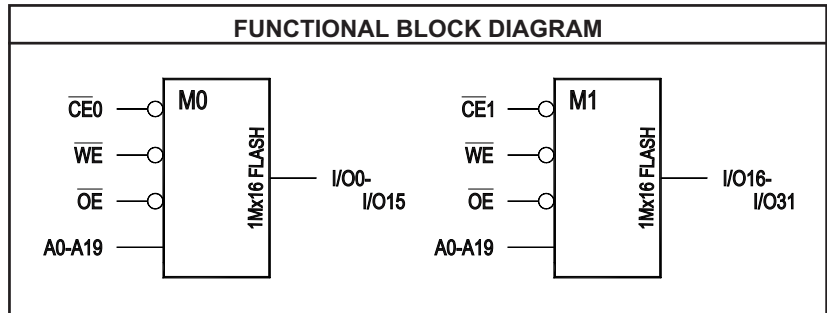

PIN-OUT DIAGRAM											
1	I/O8	12	N.C.	23	I/O15	34	I/O24	45	VDD	56	I/O31
2	I/O9	13	N.C.	24	I/O14	35	I/O25	46	N.C.	57	I/O30
3	I/O10	14	VSS	25	I/O13	36	I/O26	47	N.C.	58	I/O29
4	A13	15	I/O11	26	I/O12	37	A6	48	I/O27	59	I/O28
5	A14	16	A10	27	\overline{OE}	38	A7	49	A3	60	A0
6	A15	17	A11	28	N.C.	39	A17	50	A4	61	A1
7	A16	18	A12	29	\overline{WE}	40	A8	51	A5	62	A2
8	A18	19	VDD	30	I/O7	41	A9	52	N.C.	63	I/O23
9	I/O0	20	$\overline{CE}0$	31	I/O6	42	I/O16	53	$\overline{CE}1$	64	I/O22
10	I/O1	21	A19	32	I/O5	43	I/O17	54	VSS	65	I/O21
11	I/O2	22	I/O3	33	I/O4	44	I/O18	55	I/O19	66	I/O20

PIN NAMES	
A0 - A19	ADDRESS INPUTS: for memory address. Addresses are internally latched during a write cycle.
I/O0 - I/O31	DATA INPUT/OUTPUT: Input data commands during Command Interface Register (CIR) write cycles. Output array, status and identifier data in the appropriate read mode. Floats when the chip is de-selected or the outputs are disabled.
$\overline{CE}0, \overline{CE}1$	CHIP ENABLES: Activate the device's control logic, input buffers, decoders and sense amplifiers. With \overline{CE} high, the device is de-selected and per consumption reduces to Standby level upon completion of any current program or erase operation. \overline{CE} must be low to select the device. Device selection occurs with the falling edge of \overline{CE} . The rising edge of \overline{CE} disables the device.
\overline{WE}	WRITE ENABLES: Controls writes to the Command Interface Register (CIR). \overline{WE} is active low.
\overline{OE}	OUTPUT ENABLES: Gates the device's data through the output buffers during a read cycle. \overline{OE} is active low.
V _{DD}	DEVICE POWER SUPPLY: (+5 Volts \pm 10%)
V _{SS}	GROUND
N.C.	NO CONNECT

BUS OPERATION ¹¹

Flash memory reads, erases and writes in-system via the local CPU. All bus cycles to or from the flash memory conform to standard microprocessor bus cycles.

Mode	\overline{CE}	\overline{OE}	\overline{WE}	A0	A1	A9	I/O0 - I/O7 (I/O16 - I/O23)	I/O8 - I/O15 (I/O24 - I/O31)
Read ^{1,4}	V _{IL}	V _{IL}	V _{IH}	X	X	X	D _{OUT}	HIGH-Z
Output Disable ¹	V _{IL}	V _{IH}	V _{IH}	X	X	X	HIGH-Z	HIGH-Z
Standby ¹	V _{IH}	X	X	X	X	X	HIGH-Z	HIGH-Z
Manufacturer Identifier ^{1,3}	V _{IL}	V _{IL}	V _{IH}	V _{IL}	V _{IL}	V _{ID}	C2H	00H
Device Identifier ³	V _{IL}	V _{IL}	V _{IH}	V _{IH}	V _{IL}	V _{ID}	FAH/F1H ¹²	00H
Write ^{1,2}	V _{IL}	V _{IH}	V _{IL}	X	X	X	D _{IN}	D _{IN}

NOTES:

- X can be V_{IL} or V_{IH} for address or control pins.
- Command for different Erase operations, Data program operations can only be successfully completed through proper command sequence.
- V_{ID} = 11.5V - 12.5V.

WRITE OPERATION

Commands are written to the COMMAND INTERFACE REGISTER (CIR) using standard microprocessor write timing. The CIR serves as the interface between the microprocessor and the internal chip operation. The CIR can decipher Read Array, Read Silicon ID, Erase and Program command. In the event of a read command, the CIR simply points the read path at either the array or the Silicon ID, depending on the specific read command given. For a program or erase cycle, the CIR informs the write state machine that a program or erase has been requested. During a program cycle, the

write state machine control the program sequences and the CIR will only respond to status reads. During a sector/chip erase cycle, the CIR will respond to status reads and erase suspend. After the write state machine has completed its task, it will allow the CIR to respond to its full command set. The CIR stays at read status register mode until the microprocessor issues another valid command sequence.

Device operations are selected by writing commands into the CIR. Table 3 below defines 16 Megabit Flash family command.

DEVICE OPERATION

SILICON ID READ

The Silicon ID Read mode allows the reading out of a binary code from the device and will identify its manufacturer and type. This is intended for use by programming equipment for the purpose of automatically matching the device to be programmed with its corresponding programming algorithm. This mode is functional over the entire temperature range of the device.

To activate the mode, the programming equipment must force V_{ID} (11.5V ~ 12.5V) on address pin A9. Two identifier bytes may then be sequenced from the device outputs by toggling address A0 from V_{IL} to V_{IH} . All addresses are don't cares except A0 and A1.

The manufacturer and device codes may also be read via the command register, for instance when the device is erased or programmed in a system without access to high voltage on the A9 pin. The command sequence is illustrated in Table 2.

To terminate the operation, it is necessary to write the read/reset command sequence into the CIR.

READ RESET COMMAND

The read or reset operation is initiated by writing the read/reset command sequence into the command register. Microprocessor read cycles retrieve array data from the memory. The device remains enabled for reads until the CIR contents are altered by a valid command sequence.

The device will automatically power-up in the read/reset state. In this case, a command sequence is not required to read data. This default value ensures that no spurious alteration of the memory content occurs during the power transition. Refer to the AC Read Characteristics and Waveforms for the specific timing parameters.

Table 2: Command Definition ¹¹

Command Sequence	Bus Cycles Req'd	First Bus Write Cycle		Second Bus Write Cycle		Third Bus Write Cycle		Fourth Bus Read/Write Cycle		Fifth Bus Write Cycle		Sixth Bus Write Cycle	
		Address	Date	Address	Date	Address	Date	Address	Date	Address	Data	Address	Data
Read/Reset	4	5555H	AAH	2AAAH	55H	5555H	F0H	RA	RD	-	-	-	-
Silicon ID Read	4	5555H	AAH	2AAAH	55H	5555H	90H	00H/01H	C2H/FIH	-	-	-	-
Page/Byte Program	4	5555H	AAH	2AAAH	55H	5555H	A0H	PA	PD	-	-	-	-
Chip Erase	6	5555H	AAH	2AAAH	55H	5555H	80H	5555H	AAH	2AAAH	55H	5555H	10H
Sector Erase	6	5555H	AAH	2AAAH	55H	5555H	80H	5555H	AAH	2AAAH	55H	SA	30H
Erase Suspend	3	5555H	AAH	2AAAH	55H	5555H	B0H	-	-	-	-	-	-
Erase Resume	3	5555H	AAH	2AAAH	55H	5555H	D0H	-	-	-	-	-	-
Read Status Register	4	5555H	AAH	2AAAH	55H	5555H	70H	X	SRD	-	-	-	-
Clear Status Register	3	5555H	AAH	2AAAH	55H	5555H	50H	-	-	-	-	-	-
Sleep	3	5555H	AAH	2AAAH	55H	5555H	C0H	-	-	-	-	-	-
Abort	3	5555H	AAH	2AAAH	55H	5555H	E0H	-	-	-	-	-	-

NOTES:

Address bit A15 - A19 = X = Don't Care for all address commands except for Programming Address (PA) and Sector Address (SA).

5555H and 2AAAH address command codes stand for Hex number starting from A0 to A14.

Bus operations are defined in Table 2.

RA = Address of the memory location to be read.

PA = Address of the memory to be programmed. Addresses are latched on the falling edge of the \overline{WE} pulse.

SA = Address of the sector to be erased. The combination of A16 - A19 will be uniquely select any sector.

RD = Data read from location RA during read operation.

PD = Data to be programmed at location PA. Data is latched on the rising edge of \overline{WE} .

SRD = Data read from Status Register.

Only I/O0 - I/O7 and I/O16 - I/O23 supplies command data, I/O8-I/O15 and I/O24-I/O31 = Don't Care.

Table 3: Silicon ID Code

Type	A19	A18	A17	A16	A1	A0	Code (HEX)	I/O7	I/O6	I/O5	I/O4	I/O3	I/O2	I/O1	I/O0
Manufacturer's Code	X	X	X	X	V_{IL}	V_{IL}	C2H	1	1	0	0	0	0	1	0
Device Code	X	X	X	X	V_{IL}	V_{IH}	FAH/F1H ¹²	1	1	1	1	0	0	0	1

PAGE PROGRAM

To initiate Page Program mode, a three-cycle command sequence is required. There are two “unlock” write cycles. These are followed by writing the page program command - A0H.

After three-cycle command sequence is given, a word load is performed by applying a low pulse on the \overline{WE} or \overline{CE} input with \overline{CE} or \overline{WE} low (respectively) and \overline{OE} high. The address is latched on the falling edge of \overline{CE} or \overline{WE} , whichever occurs last. The data is latched by the first rising edge of \overline{CE} or \overline{WE} . Maximum of 64 words of data may be loaded into each page by the same procedures as outlined in the page program section below.

WORD LOAD

Word loads are used to enter the 64 words of a page to be programmed. A word load is performed by applying a low pulse on the \overline{WE} or \overline{CE} input (\overline{CE} or \overline{WE} low respectively) and \overline{OE} high. The address is latched on the falling edge of \overline{CE} or \overline{WE} , whichever occurs last. The data is latched by the first rising edge of \overline{CE} or \overline{WE} .

PROGRAM

Any page to be programmed should have the page in the erase state first, i.e. performing sector erase is suggested before page programming can be performed.

The device is programmed on a page basis. If a word of data within a page is to be changed, data for the entire page can be loaded into the device. Any word that is not loaded during the programming of its page will be still in the erase state (i.e. FFFFH). Once the words of a page are loaded into the device, they are simultaneously programmed during the internal programming period. After the first data word has been loaded into the device, successive words are entered in the same manner. Each new word to be programmed must have its high to low transition on \overline{WE} (or \overline{CE}) within 30 μ s of the low to high transition of \overline{WE} (or \overline{CE}) of the preceding word. A6 to A19 specify the page address, i.e. the device is page-aligned on 64 word boundary. The page address must be valid during each high to low transition of \overline{WE} or \overline{CE} . A0 to A5 specify the word address within the page. The word may be loaded in any order; sequential loading is not required. If a high to low transition of \overline{CE} or \overline{WE} is not detected within 100 μ s of the last low to high transition, the load period will end and the internal programming period will start. The auto page program terminates when status on I/O7 is “1” at which time the device stays at read status register mode until the CIR contents are altered by a valid command sequence. (Refer to Table 2 & 5 and Figure 1, 6 & 7)

CHIP ERASE

Chip erase is a six-bus cycle operation. There are two “unlock” write cycles. These are followed by writing the “set-up” command - 80H. Two more “unlock” write cycles are then followed by the chip erase command - 10H.

Chip erase does not require the user to program the device prior to erase.

The automatic erase begins on the rising edge of the last \overline{WE} pulse in the command sequence and terminates when the status on I/O7 (I/O23) is “1” at which time the device stays at read status register mode until the CIR contents are altered by a valid command sequence. (Refer to Tables 2 & 5 and Figures 2, 6 & 8).

SECTOR ERASE

Sector erase is a six-bus cycle operation. There are two “unlock” write cycles. These are followed by writing the set-up command - 80H. Two more “unlock” write cycles are then followed by the sector erase command - 30H. The sector address is latched on the falling edge of \overline{WE} , while the command (data) is latched on the rising edge of \overline{WE} .

Sector erase does not require the user to program the device prior to erase. The system is not required to provide any controls or timings during these operations.

The automatic sector erase begins on the rising edge of the last \overline{WE} pulse in the command sequence and terminates when the status on I/O7 (I/O23) is “1” at which time the device stays at read status register mode. The device remains enabled for read status register mode until the CIR contents are altered by a valid command sequence. (Refer to Tables 2, & 5 and Figures 3, 4, 6 & 8).

	A19	A18	A17	A16	Address Range [A0 - A15]
SA0	0	0	0	0	00000H—0FFFFH
SA1	0	0	0	1	10000H—1FFFFH
SA2	0	0	1	0	20000H—2FFFFH
SA3	0	0	1	1	30000H—3FFFFH
SA4	0	1	0	0	40000H—4FFFFH

SA15	1	1	1	1	F0000H—FFFFFH

* Per 1 Meg x 16 device.

ERASE SUSPEND

This command only has meaning while the WSM is executing SECTOR or CHIP erase operations, and therefore will only be responded to during SECTOR or CHIP erase operation. After this command has been executed, the CIR will initiate the WSM to suspend erase operations, and then return to Read Status Register mode. The WSM will set the I/O6 bit to a “1”. Once the WSM has reached the Suspend state, the WSM will set I/O7 (I/O23) bit to a “1”. At this time, WSM allows CIR to respond to the Read Array, Read Status Register, Abort and Erase Resume commands only. In this mode, the CIR will not respond to any other commands. the WSM will continue to run, idling in the SUSPEND state, regardless of the state of all input control pins.

ERASE RESUME

This command will cause the CIR to clear the suspend state and set the I/O6 (I/O22) to a “0”, but only in an Erase Suspend command was previously used. Erase Resume will not have any effect in all other conditions.

READ STATUS REGISTER COMMAND

The module contains a Status Register which may be read to determine when a program or erase operation is complete, and whether that operation completed successfully. The status register may be read at any time by writing the Read Status command to the CIR. After writing this command, all subsequent read operations output data from the status register, until another valid command is written to the CIR. A Read Array command must be written to the CIR to return to the Read Array mode.

The status register bits are output on I/O2 - I/O7 (I/O18 - I/O23) (Table 5), I/O0 - I/O1 (I/O16 - I/O17) is set to 0H.

It should be noted that the status register are latched on the falling edge of \overline{OE} or \overline{CE} whichever occurs last in the read cycle. This prevents possible bus errors which might occur if the contents of the status register change while reading the status register. \overline{CE} or \overline{WE} must be toggled with each subsequent status read, or the completion of a program or erase operation will not be evident.

The Status Register is the interface between the microprocessor and the Write State Machine (WSM). When the WSM is active, this register will indicate the status of the WSM, and will also hold the bits indicating whether or not the WSM was successful in performing the desired operation. The WSM sets status bits four through seven and clears bits six and seven, but cannot clear status bits four and five. If Erase fail or Program fail status bit is detected, the Status Register is not cleared until the Clear Status Register command is written. The device automatically outputs Status Register data when read after Chip Erase, Sector Erase, Page Program or Read Status Command write cycle. the default state of the Status Register after power-up is (I/O7 - I/O4 and I/O23 - I/O20) = 1000B. I/O3 and I/O19 = 0 or 1 depends on sector-protect status, can not be changed by Clear Status Register Command or Write State Machine. I/O2 and I/O16 = 0 or 1 depends on Sleep status, During Sleep mode or Abort mode I/O2 (I/O18) is set to "1"; I/O2 (I/O18) is reset to "0" by Read Array command.

CLEAR STATUS REGISTER

The Erase fail status bit (I/O5 and I/O21) and Program fail status bit (I/O4 and I/O20) are set by the write state machine, and can only be reset by the system software. These bits can indicate various failure conditions (see Table 5). By allowing the system software to control the resetting of these bits, several operations may be performed (such as cumulatively programming several pages or erasing multiple blocks in sequence). The Status register may then be read to determine if an error occurred during that programming or erasing series. This adds flexibility to the way the device may be programmed or erased. Additionally, once the program (erase) fail bit happens, the program (erase) operation can not be performed further. The program (erase) fail bit must be reset by system software before further page program or sector (chip) erase are attempted. To clear the status register, the Clear Status Register

command is written to the CIR. Then, any other command may be issued to the CIR. Note again that before a read cycle can be initiated, a Read command must be written to the CIR to specify whether the read data is to come from the Array, Status Register or Silicon ID.

SLEEP MODE

The device features two software controlled low-power modes: Sleep and Abort modes. Sleep mode is allowable during any current operations except that once Suspend command is issued, Sleep command is ignored. Abort mode is executed only during page Programming and Chip/Sector Erase mode.

To activate Sleep mode, a three-bus cycle operation is required. C0H command (refer to Table 2) puts the device in the Sleep mode. Once in the Sleep mode and CMOS input level applied, the power of the device is reduced to deep power-down current levels. The only threshold condition, input leakage, and output leakage.

The Sleep command allows the device to COMPLETE current operations before going into Sleep mode. Once current operation is done, device stays at read status register mode. The status registers are not reset during sleep command. Program or Erase fail bit may have been set if during program/erase mode the device retry exceeds maximum count.

During Sleep mode, the status registers, Silicon ID codes remain valid and can still be read. The device Sleep Status bit - I/O2 (I/O18) will indicate that the device is in the sleep mode.

Write and Read Array command wakes up the device out of Sleep mode, I/O2 (I/O18) is reset to "0" and device returns to standby current level.

Table 5: Status Register ¹¹

STATUS		I/O7 (I/O23)	I/O6 (I/O22)	I/O5 (I/O21)	I/O4 (I/O20)	I/O3 (I/O19)	I/O2 (I/O18)
IN PROGRESS	PROGRAM ^{a, b, f}	0	0	0	0	1/01/0	1/0
	ERASE ^{a, c, f}	0	0	0	0	1/0	1/0
	SUSPEND (NOT COMPLETE) ^{a, d, f}	0	1	0	0	1/0	1/0
	SUSPEND (COMPLETE) ^{a, d, f}	1	1	0	0	1/0	1/0
COMPLETE	PROGRAM ^{a, b, f}	1	0	0	0	1/0	1/0
	ERASE ^{a, c, f}	1	0	0	0	1/0	1/0
FAIL	PROGRAM ^{a, e, f}	1	0	0	1	1/0	1/0
	ERASE ^{a, e, f}	1	0	1	0	1/0	1/0
AFTER CLEARING STATUS REGISTER ^f		1	0	0	0	1/0	Note 'g'

NOTES:

- I/O7, I/O23: Write State Machine Status
1 = Ready, 0 = Busy
- I/O6, I/O22: Erase Suspend Status
1 = Suspend, 0 = No Suspend
- I/O5, I/O21: Erase Fail Status
1 = Fail in Erase, 0 = Successful Erase
- I/O4, I/O20: Program Fail Status
1 = Fail in Program, 0 = Successful Program
- I/O3, I/O19: Sector-Protect Status (Not Used)
- I/O2, I/O18: Sleep Status
1 = Device in Sleep Status, 0 = Device Not in Sleep Status
I/O1-I/O0, I/O17-I/O16 = Reserved for further enhancements.
These bits are reserved for future use; mask them out when polling the Status Register.
- Program Status is for the status during Page Programming mode.
- Erase Status is for the status during Sector/Chip Erase mode.
- Suspend Status is for both Sector and Chip Erase mode.
- Fail Status bit (I/O4, I/O20 or I/O5, I/O21) is provided during Page Program or Sector/Chip Erase modes respectively.
- I/O2, I/O18 = 0 or 1 depends on whether device is in the Sleep mode or not.
- Once in the Sleep mode, I/O2, I/O18 is set to "1", and is reset by read array command only.

ABORT MODE

To activate Abort mode, a three-bus cycle operation is required. The E0H command (refer to Table 3) only stops page program or Sector/Chip erase operations currently in progress and puts the device in Sleep mode. But unlike the Sleep command, the program or erase operation will not be completed. Since the data in some page/sectors is no longer valid due to an incomplete program or erase operation, the program fail bit I/O4 (I/O20) or erase fail bit I/O5 (I/O21) will be set.

After the abort command is executed and with CMOS input levels applied, the device current is reduced to the same level as in deep power-down or sleep modes. Device stays at read register mode.

During Abort mode, the status register, Silicon ID codes remain valid and can still be read. The device Sleep Status bit - I/O2 (I/O18) will indicate that the device in the sleep mode.

DATA PROTECTION

The device is designed to offer protection against accidental erasure or programming caused by spurious system level signals that may exit during power transitions. During power-up the device automatically resets the internal state machine in the read array mode. Also, with its control register architecture, alterations of the

memory contents only occurs after successful completion of specific multi-bus cycles command sequences.

the device also incorporates several features to prevent inadvertent write cycles resulting from V_{DD} power-up and power-down transitions or system noise.

LOW V_{DD} WRITE INHIBIT

To avoid initiation of a write cycle during V_{DD} power-up and power-down, a write cycle is locked out for V_{DD} less than V_{OKL} ($\approx 3.2V$, typically $3.5V$). If $V_{DD} < V_{LKO}$, the command register is disabled and all internal program/erase circuits are disabled. Under this condition the device will reset to the read mode. Subsequent writes will be ignored until the V_{DD} level is greater than V_{LKO} . It is logically correct to prevent unintentional write when V_{DD} is above V_{LKO} .

WRITE PULSE "GLITCH" PROTECTION

Noise pulses of less than 10ns (typical) on \overline{CE} or \overline{WE} will not initiate a write cycle.

LOGICAL INHIBIT

Writing is inhibited by holding any one of $\overline{OE} = V_{IL}$, $\overline{CE} = V_{IH}$ or $\overline{WE} = V_{IH}$. To initiate a write cycle \overline{CE} and \overline{WE} must be a logical zero while \overline{OE} is a logical one.

ERASE PROGRAMMING PERFORMANCE*				
PARAMETER	LIMITS			UNITS
	MIN.	TYP.	MAX.	
Chip/Sector Erase Time		150	2000	ms
Page Programming Time		3	60	ms
Chip Program Time *		48	150	sec
Erase/Program Cycles	10,000			Cycles
Byte Program Time		24		μs

* Per 1 Meg x 16 device.

LATCH UP CHARACTERISTICS				
PARAMETER	MIN.	MAX.	UNITS	
Input Voltage with Respect to V_{SS} on all pins except I/O pins	-1.0	13.5	V	
Input Voltage with Respect to V_{SS} on all I/O pins	-1.0	$V_{DD} + 1.0$	V	
Current	-100	+100	mA	
Includes all pins except V_{DD} . Test Conditions: $V_{DD} 5.0V$, one pin at a time				

RECOMMENDED OPERATING RANGE ¹						
Symbol	Characteristic	Min.	Typ.	Max.	Unit	
V _{DD}	Supply Voltage	4.5	5.0	5.5	V	
V _{IL}	Input Low Voltage	-0.5 ²		0.8	V	
V _{IH}	Input HIGH Voltage	2.0		V _{DD} +0.5	V	
T _A	Operating Temperature	C	0	+25	+70	°C
		I	-40	+25	+85	
		M/B	-55	+25	+125	
V _{ID}	A9 I.D. Input/Output	11.5		12.5	V	

ABSOLUTE MAXIMUM RATINGS ⁵			
Symbol	Parameter	Value	Unit
T _{STG}	Storage Temperature	-65 to +125	°C
T _{BIAS}	Temperature Under Bias	-55 to +125	°C
T _{OP}	Operating Temperature	-55 to 125	°C
I _{OUT}	Output Short Circuit Current	100 ⁴	mA
V _{I/O}	Input/Output Voltage ¹	-0.5 to 7.0 ²	V
V _{DD}	Supply Voltage ¹	-0.5 to 7.0 ³	V

CAPACITANCE ⁵ : T _A = +25 C, F = 1.0MHz				
Symbol	Parameter	Max.	Condition	Unit
C _{ADR}	Address Input	35	V _{IN} ² = 0V	pF
C _{CE}	Chip Enable	25		
C _{WE}	Write Enable	35		
C _{OE}	Output Enable	35		
C _{I/O}	Data Input/Output	30		

DC OUTPUT CHARACTERISTICS					
Symbol	Parameter	Condition	Min.	Max.	Unit
V _{OH}	HIGH Voltage	I _{OH} = -400μA	2.4		V
V _{OL}	LOW Voltage ⁹	I _{OL} = 2.1 mA		0.45	V

DC CHARACTERISTICS: Over Operating Ranges						
Symbol	Characteristics	Test Conditions	Limits			Unit
			Min.	Typ.	Max.	
I _{IL}	Input Load Current ⁶	V _{DD} = V _{DD} max., V _{IN} = V _{DD} or V _{SS}	-20		+20	μA
I _{OL}	Output Leakage Current ⁶	V _{DD} = V _{DD} max., V _{IN} = V _{DD} or V _{SS}	x16	-20	+20	μA
			x32	-10	+10	
I _{SB1}	V _{DD} Standby Current (CMOS)	V _{DD} = V _{DD} max., \overline{CE} = V _{DD} ± 0.2V		100	400	μA
I _{SB2}	V _{DD} Standby Current (TTL) ⁶	V _{DD} = V _{DD} max., \overline{CE} = V _{IH}		4	42	μA
I _{CC1}	V _{DD} Read current	V _{DD} = V _{DD} max., \overline{CE} = V _{IL} , Inputs - V _{IL} or V _{IH} , f = 10MHz, I _{OUT} = 0mA	x16	55	85	mA
			x32	100	160	
I _{CC2}	V _{DD} Read Current ⁶	V _{DD} = V _{DD} max., \overline{CE} = V _{IL} , Inputs - V _{IL} or V _{IH} , f = 5MHz, I _{OUT} = 0mA	x16	35	50	mA
			x32	60	90	
I _{CC3}	V _{DD} Erase Suspend Current ^{6, 8}	Block Erase in Suspend, \overline{CE} = V _{IH}	x16	10	25	mA
			x32	10	40	
I _{CC4}	V _{DD} Program Current ⁶	Program in Progress	x16	35	65	mA
			x32	60	120	
I _{CC5}	V _{DD} Erase Current	Erase in Progress	x16	35	6	mA
			x32	60	120	
V _{IL}	Input Low Voltage ⁹		-3.0		0.8	V
V _{IH}	Input High Voltage		2.4		V _{DD} +3.0	V

FIGURE 1: AUTOMATIC PAGE PROGRAM FLOW CHART ¹¹

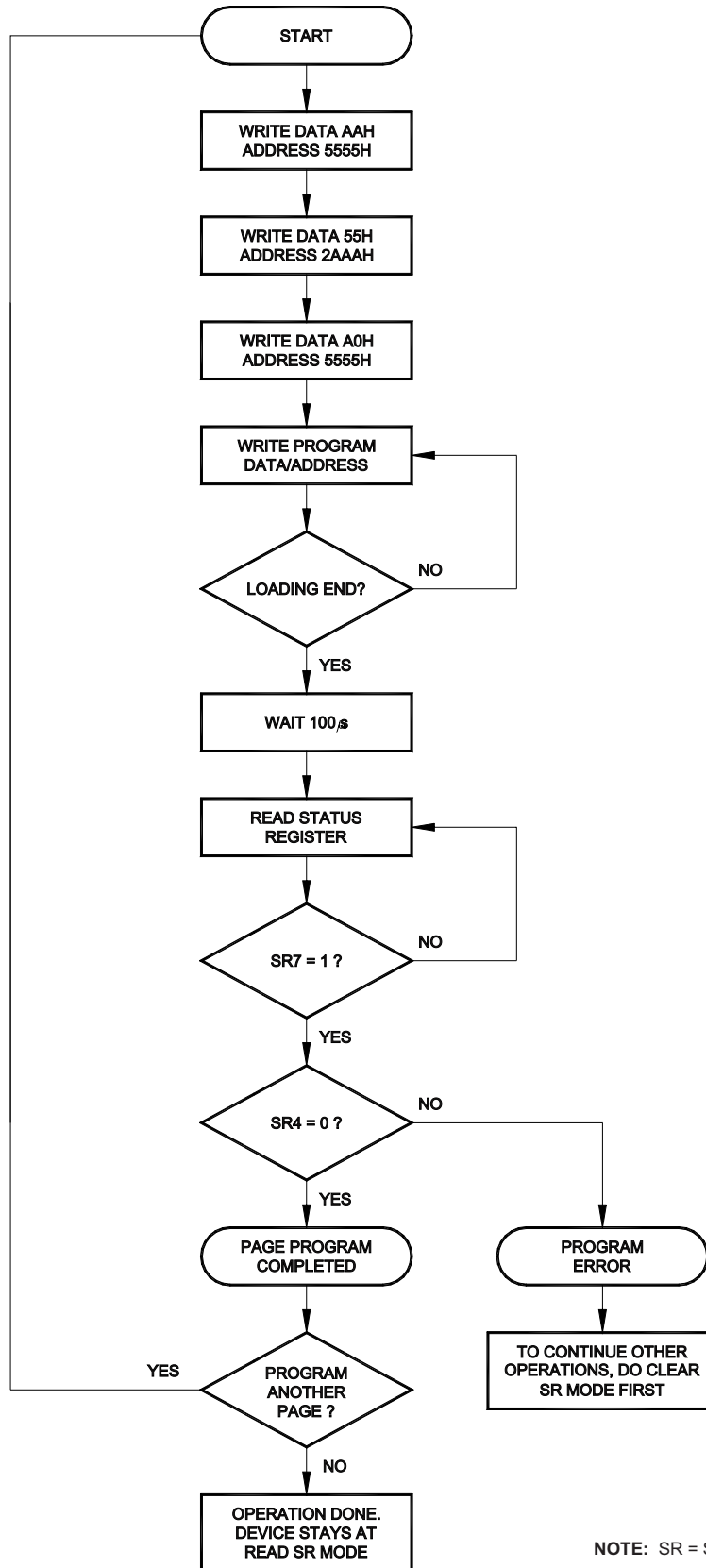

FIGURE 2: AUTOMATIC CHIP ERASE FLOW CHART ¹¹

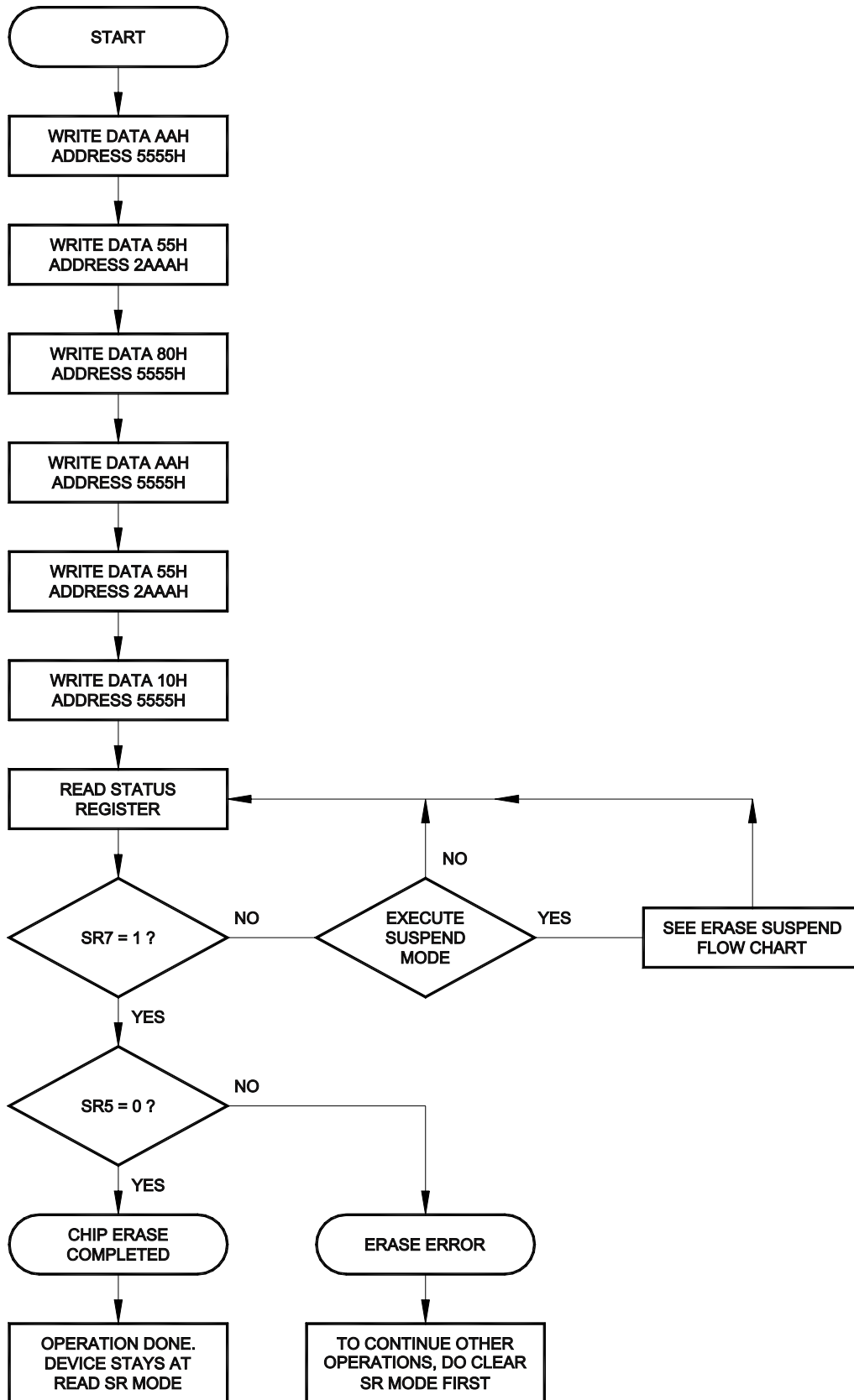

FIGURE 3: AUTOMATIC SECTOR ERASE FLOW CHART ¹¹

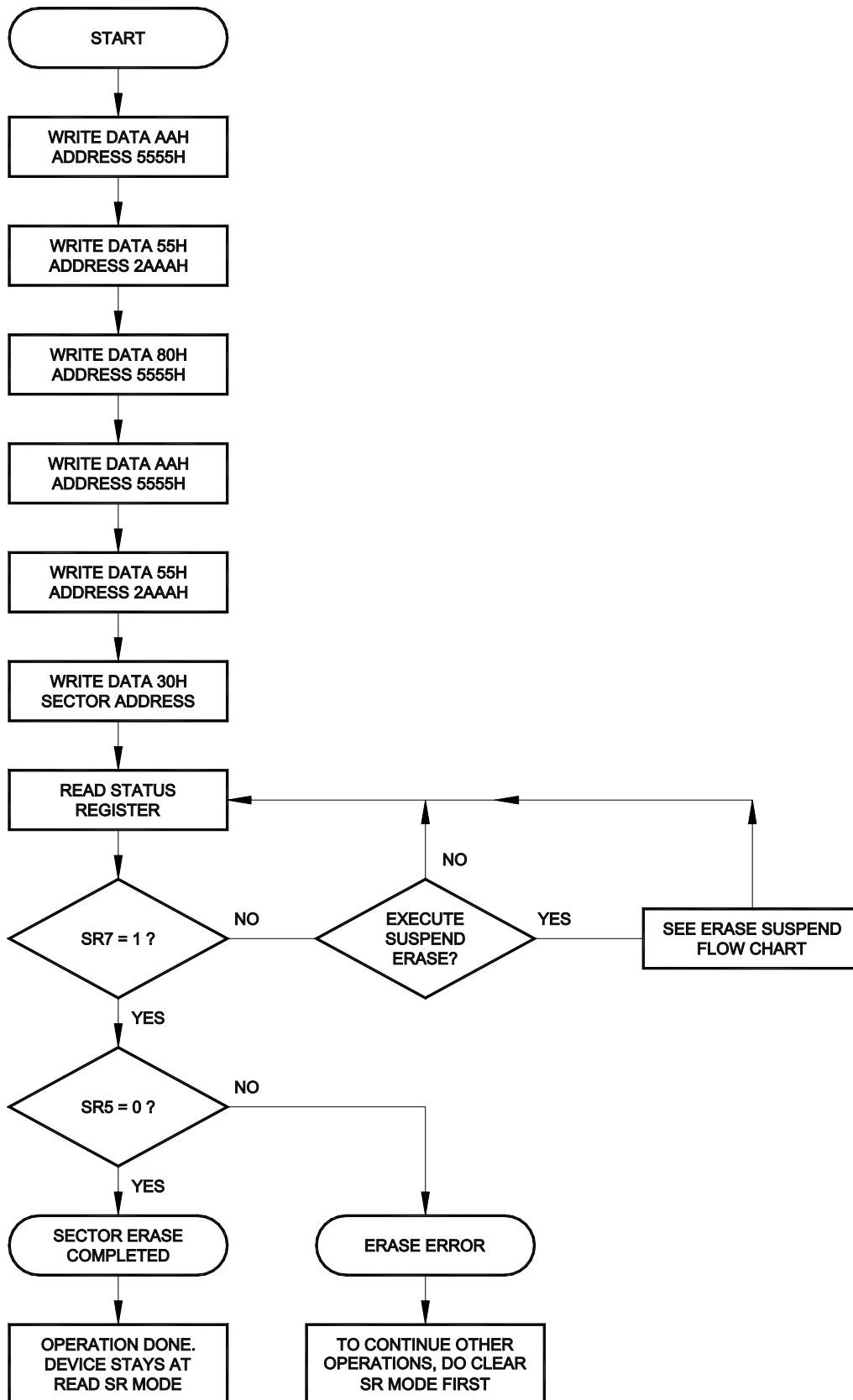
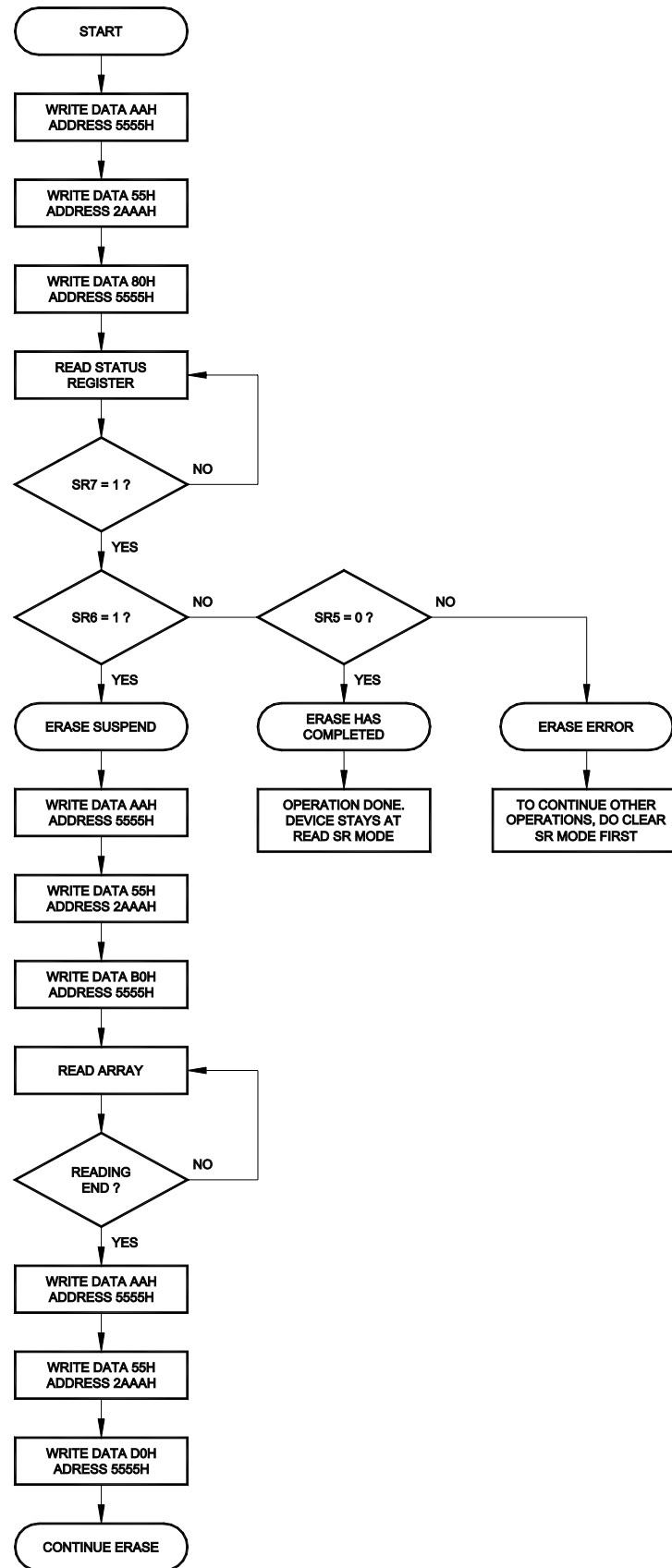
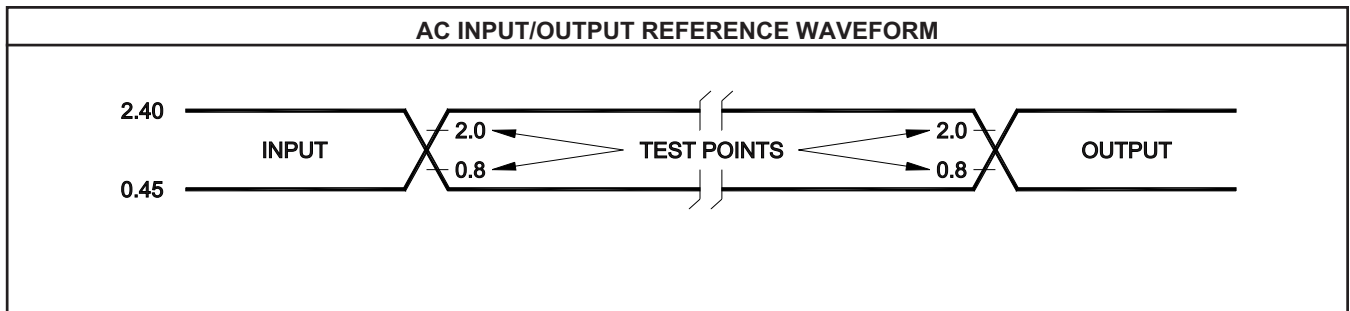
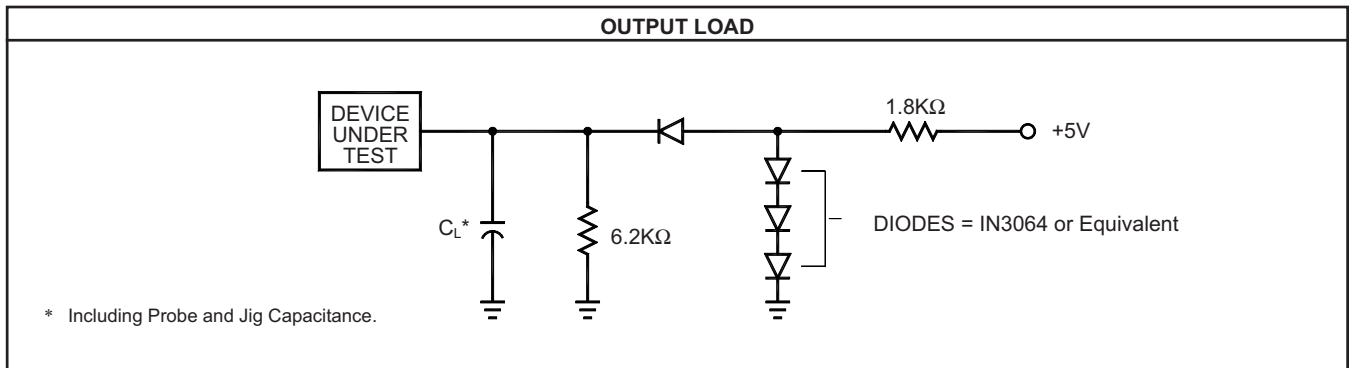

FIGURE 4: ERASE SUSPEND/ERASE RESUME FLOW CHART ¹¹



AC TEST CONDITIONS	
Input Pulse Levels	0.45V to 2.4V
Input Pulse Rise and Fall Times	10ns
Input and Output Timing Reference Levels	0.8V, 2.0V

OUTPUT LOAD		
Load	C _L	Parameters Measured
1	100pF	except t _{DF} , t _{LZ} and t _{OLZ}
2	30pF	t _{DF} , t _{LZ} and t _{OLZ}



AC Operating Conditions and Characteristics - READ CYCLE: Over operating ranges									
No.	Symbol	Parameter	120ns		150ns		200ns		Unit
			Min.	Max.	Min.	Max.	Min.	Max.	
1	t _{ACC}	Address to Output Delay		120		120		150	ns
2	t _{CE}	Chip Enable Output Delay		120		120		150	ns
3	t _{OE}	Output Enable Output Delay		60		70		70	ns
4	t _{DF}	Output Enable to Output Delay	0	55	0	55	0		ns
5	t _{OH}	Address to Output Hold	0		0		0		ns

Figure 5: READ CYCLE

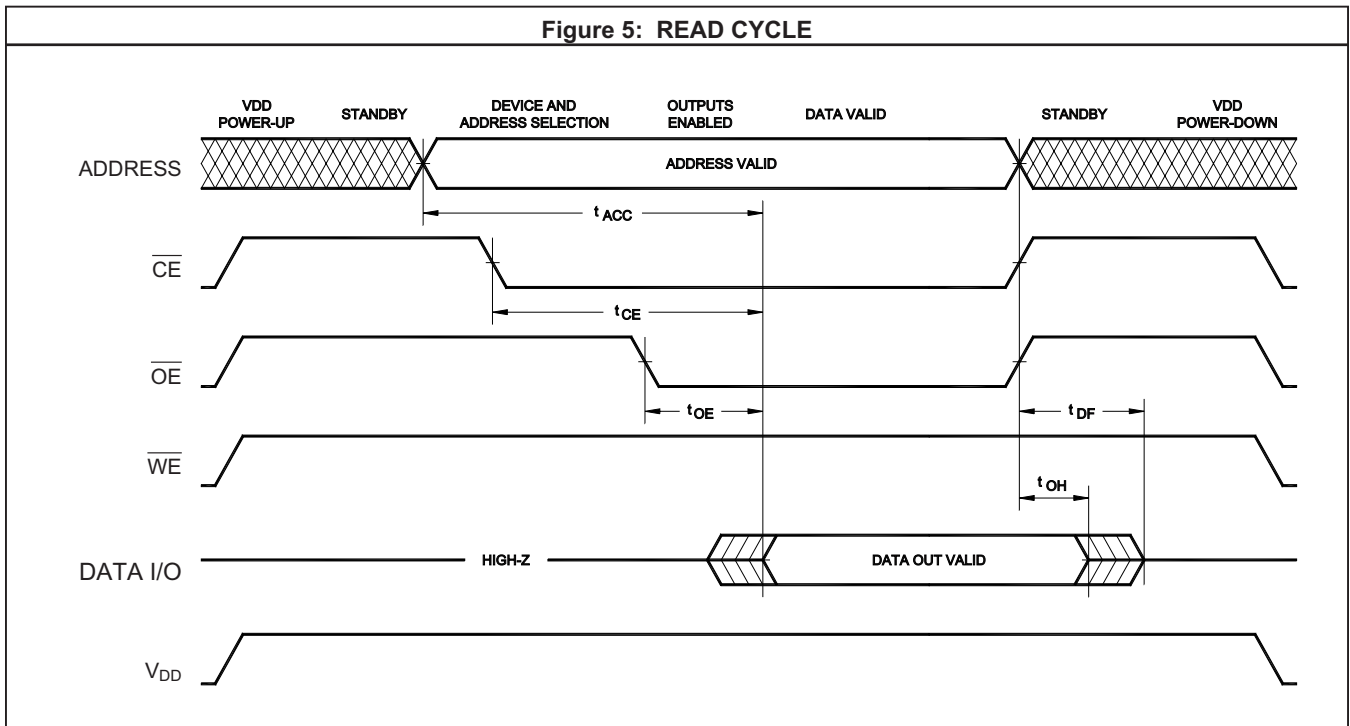

AC Operating Conditions and Characteristics - WRITE/ERASE/PROGRAM CYCLE: Over operating ranges

No.	Symbol	Parameter	120ns		150ns		200ns		Unit
			Min.	Max.	Min.	Max.	Min.	Max.	
6	t_{WC}	Write Cycle Time	120		150		200		ns
7	t_{AS}	Address Setup Time	0		0		0		ns
8	t_{AH}	Address Hold Time	50		60		70		ns
9	t_{DS}	Data Setup Time	50		60		70		ns
10	t_{DH}	Data Hold Time	10		10		10		ns
11	t_{OES}	Output Enable Setup Time	0		0		0		ns
12	t_{CES}	Chip Enable Setup Time	0		0		0		ns
13	t_{GHWL}	Read Recovery Time before Write	0		0		0		ns
14	t_{CS}	Chip Enable Setup Time	0		0		0		ns
15	t_{CH}	Chip Enable Hold Time	0		0		0		ns
16	t_{WP}	Write Pulse Width	50		60		70		ns
17	t_{WPH}	Write Pulse Width HIGH	50		50		50		ns
18	t_{BALC}	Byte Address Load Cycle	0.3	30	0.3	30	0.3	30	μ s
19	t_{BAL}	Byte Address Load Time	100		100		100		μ s
20	t_{SRA}	Status Register Access Time	120		150		200		ns
21	t_{CESR}	Chip Enable Setup before SR Read	100		100		100		ns
22	t_{VCS}	VDD Setup Time	2		2		2		μ s

Figure 6: WRITE CYCLE

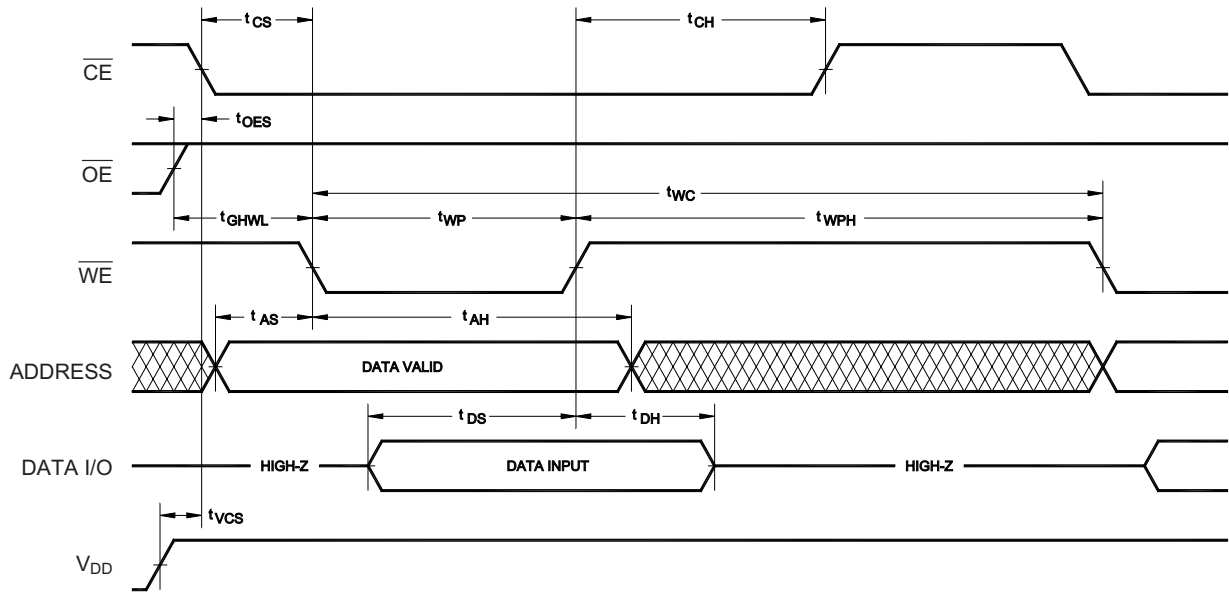

Figure 7: AUTOMATIC PAGE PROGRAM CYCLE ¹⁰

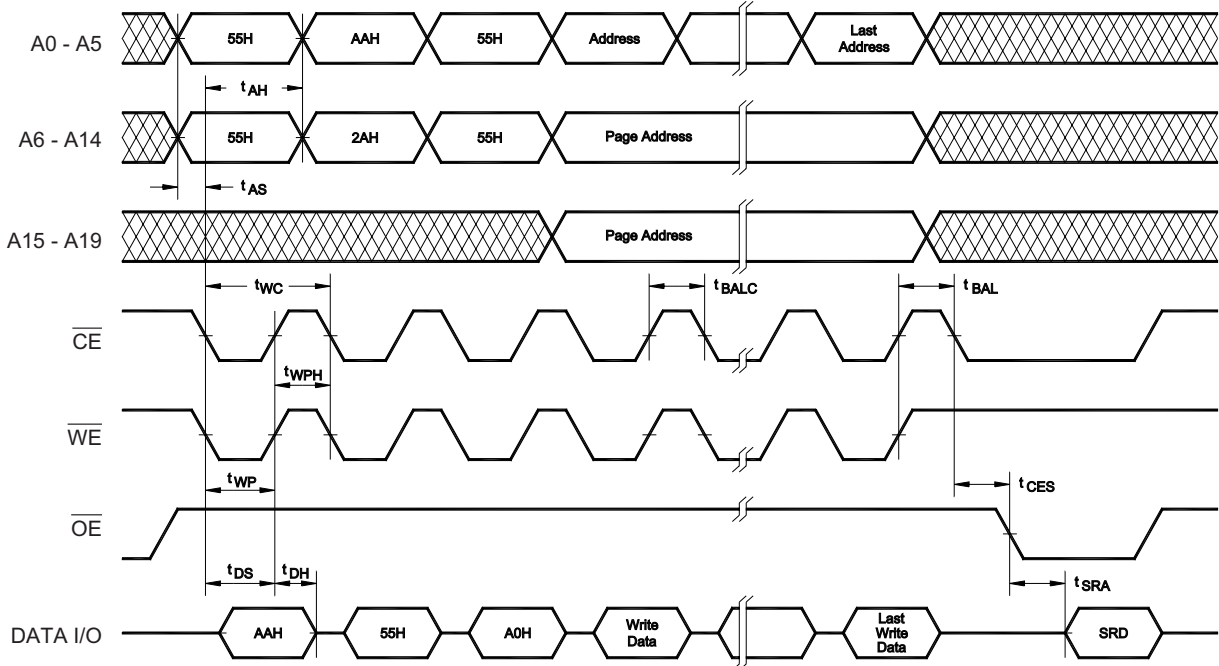
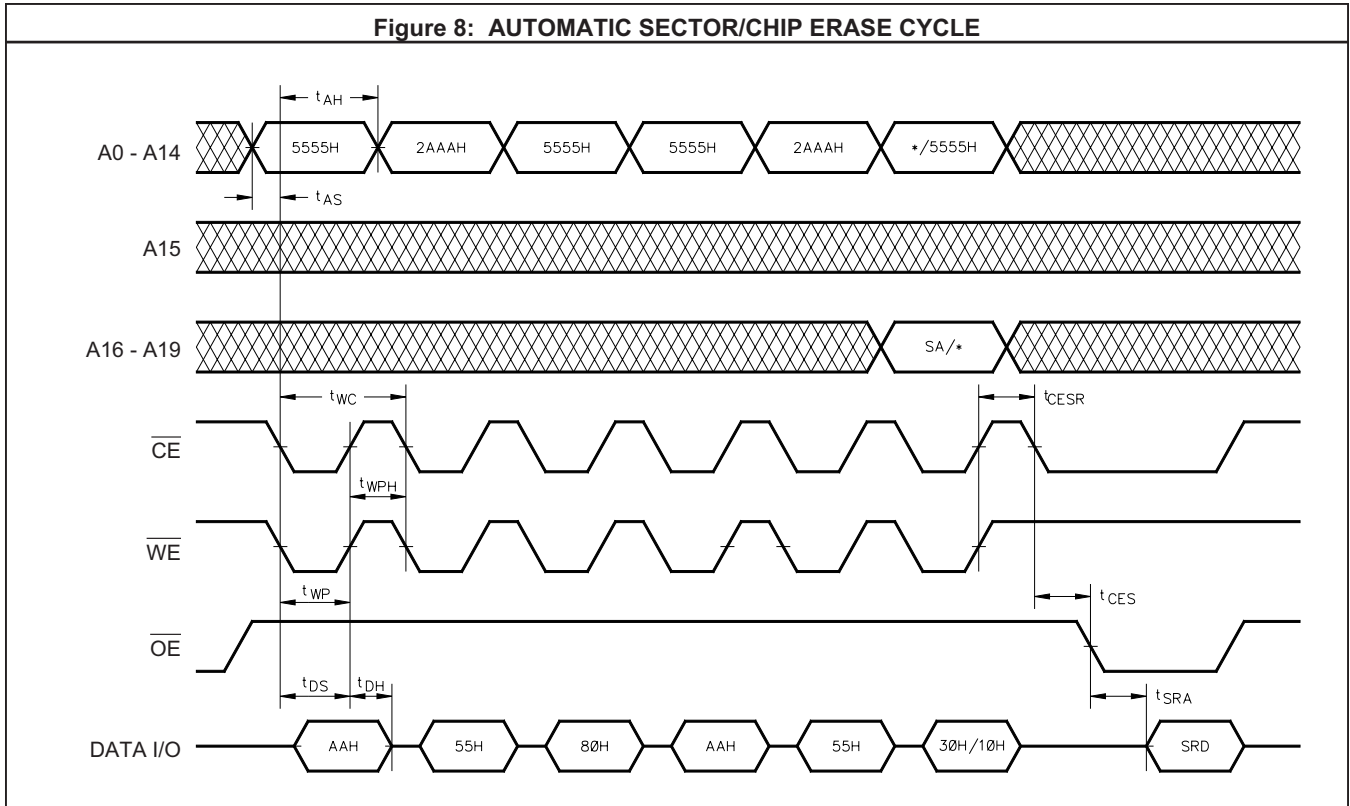

Figure 8: AUTOMATIC SECTOR/CHIP ERASE CYCLE



AC Operating Conditions and Characteristics: Over operating ranges
WRITE/ERASE/PROGRAM OPERATION ALTERNATE CE CONTROLLED WRITES

No.	Symbol	Parameter	120ns		150ns		200ns		Unit
			Min.	Max.	Min.	Max.	Min.	Max.	
23	t_{WC}	Write Cycle Time	120		150		200		ns
24	t_{AS}	Address Setup Time	0		0		0		ns
25	t_{AH}	Address Hold Time	50		60		70		ns
26	t_{DS}	Data Setup Time	50		60		70		ns
27	t_{DH}	Data Hold Time	10		10		10		ns
28	t_{OES}	Output Enable Setup Time	0		0		0		ns
29	t_{CES}	Chip Enable Setup Time	0		0		0		ns
30	t_{GHWL}	Read Recovery Time before Write	0		0		0		ns
31	t_{WS}	Write Enable Setup Time	0		0		0		ns
32	t_{WH}	Write Enable Hold Time	0		0		0		ns
33	t_{CP}	Chip Enable Pulse Width	50		60		70		ns
34	t_{CPH}	Chip Enable Pulse Width HIGH	50		50		50		ns
35	t_{VCS}	V_{DD} Setup Time	2		2		2		μ s

Figure 9: COMMAND WRITE CYCLE (Alternate \overline{CE} Controlled)

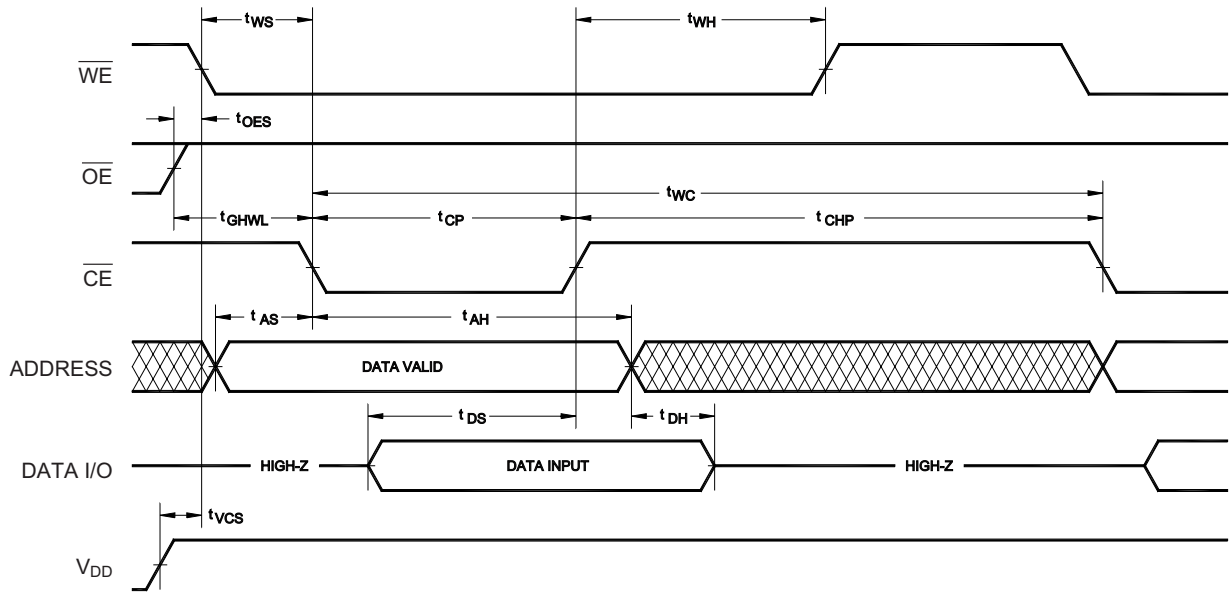
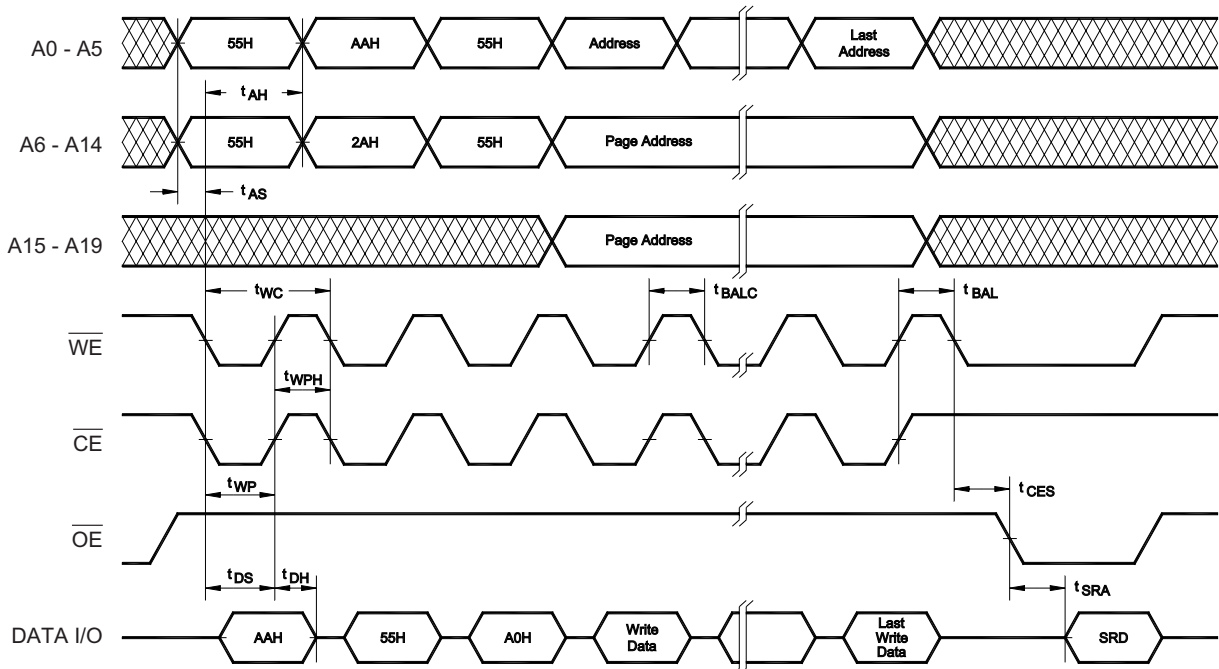
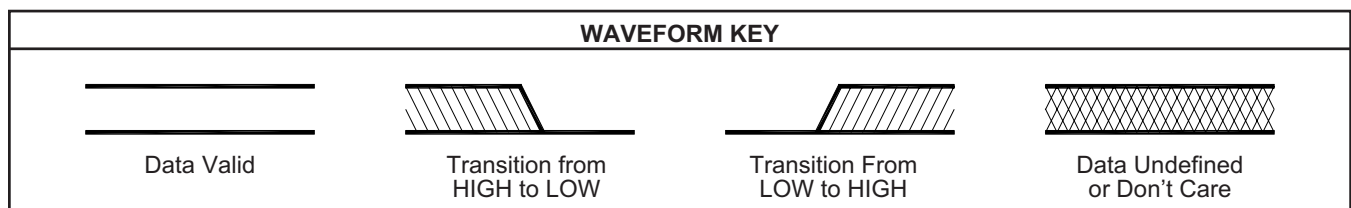

Figure 10: AUTOMATIC PAGE PROGRAM TIMING CYCLE ¹⁰



NOTES:

1. All voltages are with respect to V_{SS} .
2. -2.0V min. for pulse width less than 20ns (V_{IL} min. = -0.5V at DC level).
3. Maximum DC voltage on V_{PP} or A9 may over shoot to +14.0V for periods less than 20ns.
4. Stresses greater than those under **ABSOLUTE MAXIMUM RATINGS** may cause permanent damage to the device. This is a stress rating only and functional operation of the device at these or any other conditions above those indicated in the operational sections of this specification is not implied. Exposure to absolute maximum rating conditions for extended periods may affect reliability.
5. This parameter is guaranteed and not 100% tested.
6. All currents are in RMS unless otherwise noted. Typical values at $V_{DD} = 5.0V$, $t = 25^{\circ}C$. These currents are valid for all product versions (package and speeds.).
7. I_{CC3} is specified with the device de-selected. If the device is read while in erase suspend mode, current draw is the sum of I_{CC3} and I_{CC1}/I_{CC2} .
8. V_{IL} min. = -1.0V for pulse width $\leq 50ns$.
9. V_{IL} min. = -2.0V for pulse width $\leq 20ns$.
10. Refer to page 5 for detail Page Program Operation.
11. Each SLCC contains one 1 Meg x 16 FLASH memory device enabled by separate chip enables. Typically the module is used as a x32 device. When writing commands to the command register (CIR) under these conditions, the command sequence shown in the command definition table should be duplicated to each word (I/O0 - I/O15 and I/O16 - I/O31) of the module. The command sequence for a Read/Reset cycle would be as follows: On the first bus cycle XXAAXXAAH would be written to Address 5555H, on the second bus cycle XX55XX55H would be written to address 2AAAH followed on the third bus cycle by XXF0XXF0H being written to address 5555H (in this example X = Don't Care). A single device can be programmed by writing the appropriate command sequence to that device while writing the Read/Rest command sequence to the other enabled device.
12. FAH is the device identification for Macronix Revision A die (MX29F1610AHC). F1H is the device identification for Macronix non-revision die (MX29F1610HC).



ORDERING INFORMATION

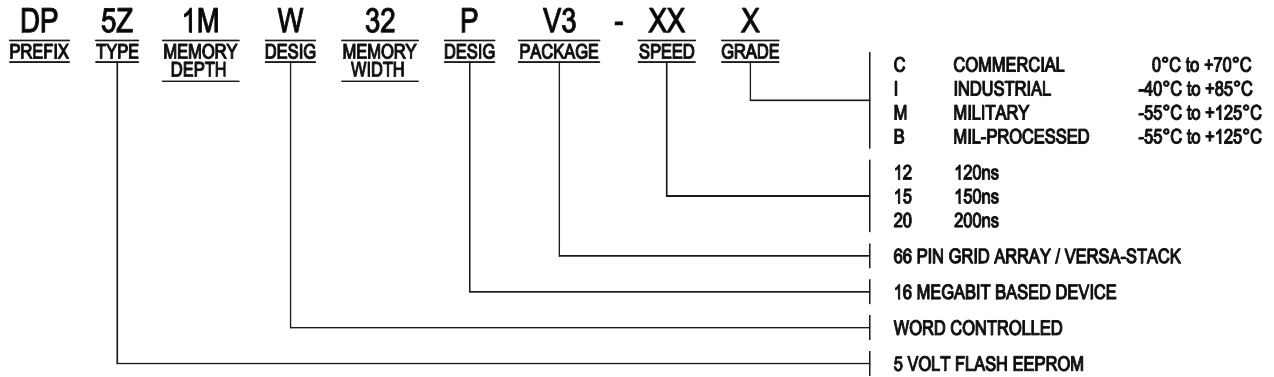

MECHANICAL DRAWING

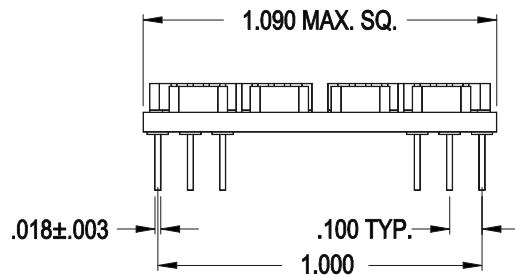
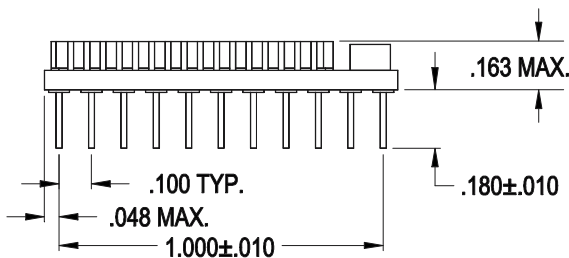
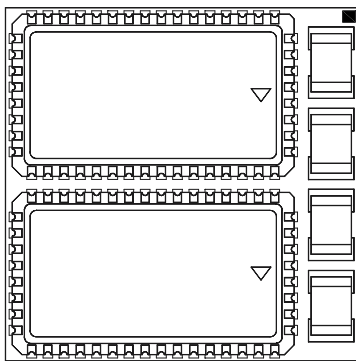

DPAC Technologies Products & Services for the Integration Age
 7321 Lincoln Way, Garden Grove, CA 92841 Tel 714 898 0007 Fax 714 897 1772
 www.dpactech.com Nasdaq: DPAC

©2002 DPAC Technologies, all rights reserved. DPAC Technologies™, Versa-Stack™, LP-Stack™, CS Stack™ are trademarks of DPAC Technologies Corp.