

Low-Power, Low-Voltage, 24-Bit $\Delta\Sigma$ ADC

Features

- $\Delta\Sigma$ Analog-to-Digital Converter
 - Linearity Error: 0.0015% FS
 - RMS Noise: 2 μ V
- Two Channel Differential MUX
- Buffered, Fully Differential Analog and Voltage Reference Inputs
- Scalable V_{REF} Input: 0.1 V to Analog Supply
- Absolute Accuracy via Calibration
- Flexible Digital Filters
 - Single Conversion Settling at 13.4 SPS or 4 Conversion Settling at 53.7 SPS with Simultaneous 50/60 Hz Rejection
 - Single Conversion Settling at 64.8 SPS or Four Conversion Settling at 260 SPS with 16-bit Resolution
- Simple 3-Wire Serial Interface
 - SPI™ and Microwire™ Compatible
 - Schmitt Trigger on Serial Clock (SCLK)
- Low Power
 - Single +3.0 V Supply
 - 330 μ A Operating; 10 μ A Sleep Current

Description

The CS5541 is a 24-bit low-power and low-voltage $\Delta\Sigma$ analog-to-digital converter (ADC). It is optimized to convert analog signals in DC measurement applications, such as temperature and pressure measurement, and various portable devices where low-power consumption is required.

To accommodate these applications, the ADC integrates analog input and reference buffers for increased input impedance and includes a two-channel multiplexer. Absolute accuracy is achieved via one-time or continuous calibration modes. The device draws less than 330 μ A.

The CS5541 includes two digital filters. The first filter, which achieves simultaneous rejection of 50/60 Hz, provides single conversion settling at 13.4 SPS throughput or four conversion settling at 53.7 SPS throughput. The second filter, which achieves 16-bit performance, provides single conversion settling at 64.8 SPS throughput or four conversion settling at 260 SPS throughput.

Low-power, low-voltage operation and an easy-to-configure serial interface reduces time-to-market and makes the CS5541 an ideal device for low-cost, power-conscious DC measurement applications.

ORDERING INFORMATION

CS5541-BS-40 °C - +85 °C

16-Pin SSOP

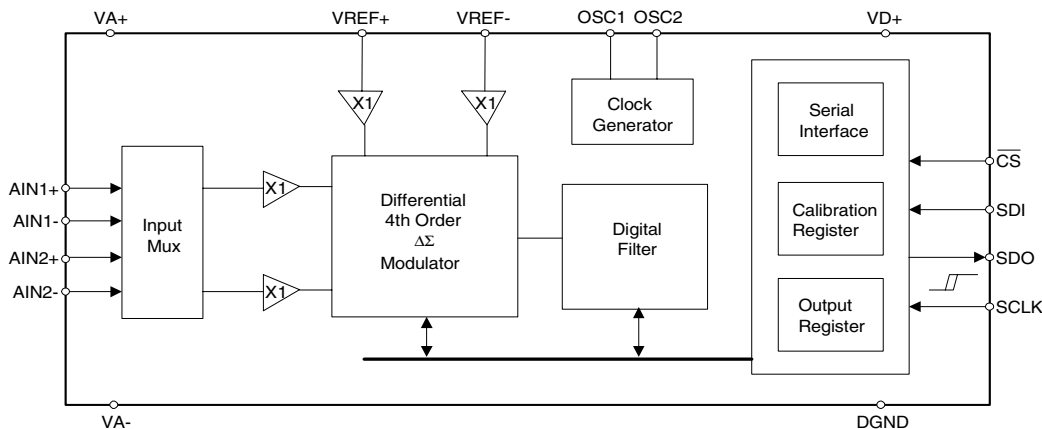

Preliminary Product Information

This document contains information for a new product. Cirrus Logic reserves the right to modify this product without notice.

TABLE OF CONTENTS

1. CHARACTERISTICS AND SPECIFICATIONS	4
2. GENERAL DESCRIPTION	10
2.1 Analog Input	10
2.1.1 Analog Input Model	10
2.2 Voltage Reference Input	11
2.2.1 Voltage Reference Input Model	11
2.3 Power Supply Arrangements	12
2.4 Clock Generator	12
2.5 Serial Port Interface	12
2.6 Serial Port	13
2.7 Serial Port Initialization Sequence	14
2.8 Command Register Quick Reference	15
2.9 Performing Conversions/Calibrations	16
2.9.1 Continuous Calibrations and Conversions (reduced output rate)	16
2.9.2 One Time Calibration followed by Continuous Conversions	17
2.9.3 Continuous Conversions with Default Calibration Coefficients	17
2.9.4 Continuous Conversions with Existing Calibration Coefficients	17
2.9.5 System Calibration	17
2.9.6 Reading Conversions	17
2.9.7 Output Coding	18
2.9.8 Digital Filter	18
2.10 Sleep and Standby Modes	20
2.11 Power-Up Sequence and Initialization	20
2.12 PCB Layout	20
3. PIN DESCRIPTIONS	22
4. SPECIFICATION DEFINITIONS	24

Contacting Cirrus Logic Support

For a complete listing of Direct Sales, Distributor, and Sales Representative contacts, visit the Cirrus Logic web site at: <http://www.cirrus.com/corporate/contacts/>

SPI is a trademark of Motorola Inc.
Microwire is a trademark of National Semiconductor Corp.

Preliminary product information describes products which are in production, but for which full characterization data is not yet available. Advance product information describes products which are in development and subject to development changes. Cirrus Logic, Inc. has made best efforts to ensure that the information contained in this document is accurate and reliable. However, the information is subject to change without notice and is provided "AS IS" without warranty of any kind (express or implied). No responsibility is assumed by Cirrus Logic, Inc. for the use of this information, nor for infringements of patents or other rights of third parties. This document is the property of Cirrus Logic, Inc. and implies no license under patents, copyrights, trademarks, or trade secrets. No part of this publication may be copied, reproduced, stored in a retrieval system, or transmitted, in any form or by any means (electronic, mechanical, photographic, or otherwise) without the prior written consent of Cirrus Logic, Inc. Items from any Cirrus Logic website or disk may be printed for use by the user. However, no part of the printout or electronic files may be copied, reproduced, stored in a retrieval system, or transmitted, in any form or by any means (electronic, mechanical, photographic, or otherwise) without the prior written consent of Cirrus Logic, Inc. Furthermore, no part of this publication may be used as a basis for manufacture or sale of any items without the prior written consent of Cirrus Logic, Inc. The names of products of Cirrus Logic, Inc. or other vendors and suppliers appearing in this document may be trademarks or service marks of their respective owners which may be registered in some jurisdictions. A list of Cirrus Logic, Inc. trademarks and service marks can be found at <http://www.cirrus.com>.

LIST OF FIGURES

Figure 1. Continuous Running SCLK Timing (Not to Scale)	9
Figure 2. SDI Write Timing (Not to Scale)	9
Figure 3. SDO Read Timing (Not to Scale)	9
Figure 4. Multiplexer Configuration.	10
Figure 5. Input model for AIN+ and AIN- pins.	10
Figure 6. Resolution vs. Voltage Reference	11
Figure 7. Resolution vs. Voltage Reference	11
Figure 8. Input model for VREF+ and VREF- pins.	11
Figure 9. CS5541 Configured with +3.0 V Analog Supply.	12
Figure 10. CS5541 Register Diagram.	13
Figure 11. Command and Data Word Timing.	13
Figure 12. Self Calibration of Offset.	16
Figure 13. Self Calibration of Gain.	16
Figure 14. Digital Filter 1 Response	19
Figure 15. Filter 2 Response (MCLK = 32.768 kHz)	19

LIST OF TABLES

Table 1. Filter Output Word Rates	14
Table 2. Output Conversion Data Register Description (24 bits + flags)	18
Table 3. CS5541 24-Bit Output Coding.....	19

1. CHARACTERISTICS AND SPECIFICATIONS

ANALOG CHARACTERISTICS ($T_A = 25\text{ }^\circ\text{C}$; $V_{A+} = +3\text{ V} \pm 5\%$, $V_{A-} = 0\text{ V}$, $V_{D+} = +3.0\text{ V} \pm 5\%$, $DGND = 0\text{ V}$, $V_{REF+} = 2.5\text{ V}$, $V_{REF-} = 0\text{ V}$, $MCLK = 32.768\text{ kHz}$, OWR (Output Word Rate) = 53.7 SPS , Bipolar Mode, Input Range = $\pm 2.5\text{ V}$ Differential, $V_{cm} = 1.25\text{ V}$.) (See Notes 1 and 2.)

Parameter	Min	Typ	Max	Units
Accuracy				
Linearity Error	-	± 0.0015	± 0.003	%FS
No Missing Codes	24	-	-	Bits
Bipolar Offset (Note 3)	-	± 16	TBD	LSB_{24}
Unipolar Offset (Note 3)	-	± 32	TBD	LSB_{24}
Offset Drift (Notes 3 and 4)	-	20	-	$nV/^\circ\text{C}$
Bipolar Full Scale Error	-	± 8	± 31	ppm
Unipolar Full Scale Error	-	± 16	± 62	ppm
Full Scale Drift (Note 4)	-	1	-	$ppm/^\circ\text{C}$

Noise (Notes 5, 6, and 7)			
Filter Type	Output Word Rate (SPS)	-3 dB Filter Frequency (Hz)	RMS Noise (μV)
Single Conversion Settling with 50/60 Hz Rejection	13.4	11.96	2
Four Conversion Settling with 50/60 Hz Rejection	53.7	11.96	2
Fast Filter with Single Conversion Settling	64.8	56.91	35
Fast Filter with Four Conversion Settling	260	56.91	35

- Notes:
1. Applies after a one-time self-calibration at any temperature within $-40\text{ }^\circ\text{C} \sim +85\text{ }^\circ\text{C}$.
 2. Specifications guaranteed by design, characterization, and/or test.
 3. Specification applies to the device only and does not include any effects by external parasitic thermocouples.
 4. Drift over specified temperature range after calibration at power-up at $25\text{ }^\circ\text{C}$.
 5. Wideband noise aliased into the baseband. Referred to the input. Typical values shown for $25\text{ }^\circ\text{C}$.
 6. For peak-to-peak noise multiply by 6.6 for all ranges and output rates.
 7. RMS noise numbers assume continuous calibration mode is not used. In continuous calibration mode the noise increases by a factor of two.

* Specifications are subject to change without notice.

ANALOG CHARACTERISTICS (Continued)

Parameter		Min	Typ	Max	Units
Analog Inputs					
Common Mode + Signal on AIN+ or AIN- Single Supply Dual Supply	(Bipolar/Unipolar Mode)	0.0	-	VA+	V
		VA-	-	VA+	V
CVF Current on AIN+, AIN-	(Note 8)	-	12	-	nA
Input Leakage for MUX when off		-	10	-	pA
Common Mode Rejection	dc	-	120	-	dB
	50, 60Hz	-	120	-	dB
Input Capacitance		-	8	-	pF
Voltage Reference Inputs					
Range	(VREF+) - (VREF-) (Note 10)	0.1	2.5	(VA+) - (VA-)	V
CVF Current on VREF+ and VREF-	(Note 9)	-	20	-	nA
Common Mode Rejection	dc	-	120	-	dB
	50, 60 Hz	-	120	-	dB
Input Capacitance		-	12	-	pF
Dynamic Characteristics					
Modulator Sampling Frequency		-	MCLK/2	-	Hz
Filter Settling to 1/2 LSB (Full Scale Step)	(Note 11)	-	-	-	-
	13.4 SPS OWR	-	1/OWR	-	s
	53.7 SPS OWR	-	4/OWR	-	s
	64.8 SPS OWR	-	1/OWR	-	s
260 SPS OWR	-	4/OWR	-	s	
Power Supplies					
DC Power Supply Currents	(Normal Mode)	-	-	-	-
	IA+	-	225	280	μA
	ID+	-	25	36	μA
Power Consumption	Normal Mode (Note 12)	-	750	1000	μW
	Standby Mode	-	75	-	μW
	Sleep Mode	-	30	-	μW
Power Supply Rejection	dc Positive Supplies	-	80	-	dB
	dc Negative Supply	-	80	-	dB

Notes: 8. See Section 2.1, “Analog Input”.

9. See Section 2.2, “Voltage Reference Input”.

10. VREF must be less than or equal to supply voltages.

11. The CS5541 includes two digital filters. The first filter, which achieves simultaneous rejection of 50/60 Hz, provides single conversion settling at 13.4 SPS throughput or four conversion settling at 53.7 SPS throughput. The second filter, which achieves 16-bit performance, provides single conversion settling at 64.8 SPS throughput or four conversion settling at 260 SPS throughput.

12. All outputs unloaded. All digital inputs at CMOS levels.

3 V DIGITAL CHARACTERISTICS ($T_A = 25\text{ }^\circ\text{C}$; $V_{A+} = 3.0\text{ V} \pm 5\%$, $V_{A-} = 0\text{ V}$, $V_{D+} = 3.0\text{ V} \pm 5\%$, $DGND = 0\text{ V}$.) (See Notes 2 and 13.)

Parameter			Symbol	Min	Typ	Max	Units
High-Level Input Voltage:	All Pins Except	OSC1, SCLK	V_{IH}	$0.6V_{D+}$	-	-	V
		OSC1	V_{IH}	TBD	-	-	V
		SCLK	V_{IH}	$(V_{D+})-0.45$	-	-	V
Low-Level Input Voltage:	All Pins Except	OSC1, SCLK	V_{IL}	-	-	$0.16V_{D+}$	V
		OSC1	V_{IL}	-	-	TBD	V
		SCLK	V_{IL}	-	-	0.6	V
High-Level Output Voltage:	(SDO pin)	$I_{out} = -1.0\text{ mA}$	V_{OH}	$(V_{D+})-0.25$	-	-	V
Low-Level Output Voltage:	(SDO pin)	$I_{out} = 1.0\text{ mA}$	V_{OL}	-	-	0.2	V
Input Leakage Current			I_{in}	-	± 1	± 10	μA
3-State Leakage Current			I_{OZ}	-	-	± 10	μA
Digital Output Pin Capacitance			C_{out}	-	9	-	pF

Notes: 13. All measurements performed under static conditions.

ABSOLUTE MAXIMUM RATINGS (DGND = 0 V) (See Note 14.)

Parameter	Symbol	Min	Typ	Max	Units	
DC Power Supplies (Notes 15 and 16)	Positive Digital	VD+	-0.3	-	+4.0	V
	Positive Analog	VA+	-0.3	-	+4.0	V
	Negative Analog	VA-	-0.3	-	+0.3	V
Input Current, Any Pin Except Supplies (Notes 17 and 18)	I _{IN}	-	-	±10	mA	
Output Current	I _{OUT}	-	-	±25	mA	
Power Dissipation (Note 19)	PDN	-	-	500	mW	
Analog Input Voltage AIN and VREF pins	V _{INA}	(VA-) + (-0.3)	-	(VA+)+0.3	V	
Digital Input Voltage	V _{IND}	-0.3	-	(VD+)+0.3	V	
Ambient Operating Temperature	T _A	-40	-	+85	°C	
Storage Temperature	T _{stg}	-65	-	+150	°C	

Notes: 14. All voltages measured with respect to digital ground (DGND).

15. VA+ and VA- must satisfy $\{(VA+) - (VA-)\} \leq +4.0$ V.

16. VD+ and VA- must satisfy $\{(VD+) - (VA-)\} \leq +4.0$ V.

17. Applies to all pins including continuous overvoltage conditions at the analog input (AIN) pins.

18. Transient currents up to 100 mA will not cause SCR latch-up. Maximum input current for a power supply pin is ±50 mA.

19. Total power dissipation, including all input currents and output currents.

WARNING: Operation at or beyond these limits may result in permanent damage to the device.

Normal operation is not guaranteed at these extremes.

SWITCHING CHARACTERISTICS ($T_A = 25\text{ }^\circ\text{C}$; $V_{A+} = +3.0\text{ V} \pm 5\%$ $V_{A-} = 0\text{ V}$, $V_{D+} = 3.0\text{ V} \pm 5\%$, $DGND = 0\text{ V}$; Input Levels: Logic 0 = 0 V, Logic 1 = V_{D+} ; $C_L = 50\text{ pF}$)

Parameter	Symbol	Min	Typ	Max	Units
Master Clock Frequency:	External Clock	5	-	40	kHz
	Internal Oscillator (Note 20)	-	32.768	-	
Master Clock Duty Cycle		40	-	60	%
Rise Times	(Note 21) Any Digital Input Except SCLK	t_{rise}	-	1.0	μs
	SCLK		-	100	μs
	Any Digital Output		50	-	ns
Fall Times	(Note 21) Any Digital Input Except SCLK	t_{rise}	-	1.0	μs
	SCLK		-	100	μs
	Any Digital Output		50	-	ns
Start-up					
Oscillator Start-up Time	XTAL = 32.768 kHz (Note 22)	t_{ost}	-	500	ms
Power-on-Reset Period		t_{por}	-	490	MCLK cycles
Serial Port Timing					
Serial Clock Frequency	SCLK	0	-	2	MHz
Serial Clock	Pulse Width High	t_1	250	-	ns
	Pulse Width Low	t_2	250	-	ns
SDI Write Timing					
CS Enable to SCLK Rising		t_3	50	-	ns
Data Set-up Time prior to SCLK rising		t_4	50	-	ns
Data Hold Time After SCLK Rising		t_5	100	-	ns
SCLK Falling Prior to CS Disable		t_6	100	-	ns
SDO Read Timing					
CS to Data Valid		t_7	-	150	ns
SCLK Falling to New Data Bit		t_8	-	150	ns
CS Rising to SDO Hi-Z		t_9	-	150	ns

Notes: 20. Device parameters are specified with 32.768 kHz clock; however, clocks up to 40 kHz can be used for increased throughput.

21. Specified using 10% and 90% points on waveform of interest. Output loaded with 50 pF.

22. Oscillator start-up time varies with crystal parameters. This specification does not apply when using an external clock source.

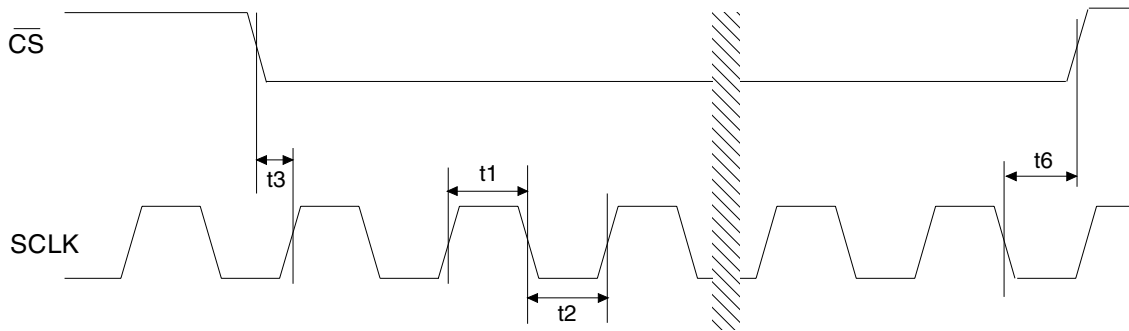

Figure 1. Continuous Running SCLK Timing (Not to Scale)

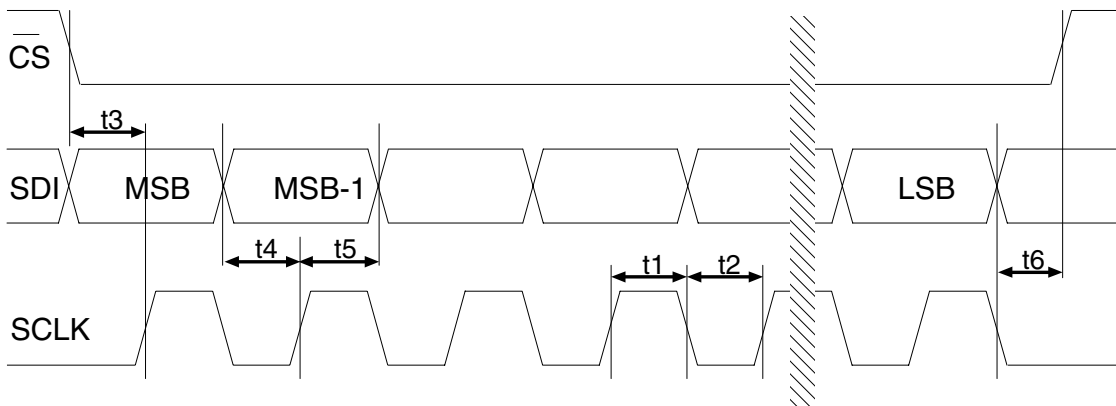

Figure 2. SDI Write Timing (Not to Scale)

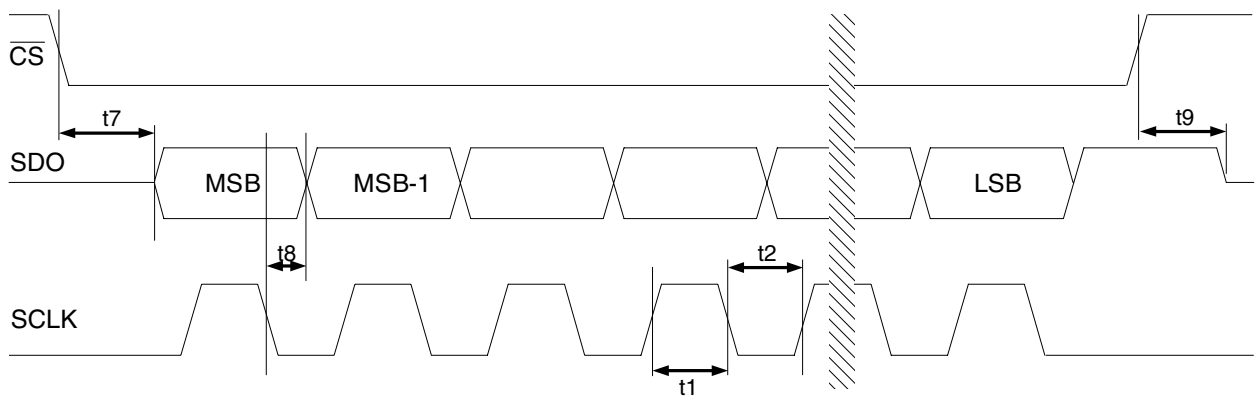

Figure 3. SDO Read Timing (Not to Scale)

2. GENERAL DESCRIPTION

The CS5541 is a 24-bit, low-power and low-voltage Δ - Σ analog-to-digital converter (ADC). It is optimized to convert analog signals in DC measurement applications such as temperature and pressure measurement, and various portable devices where low power consumption is required.

To accommodate these applications, the ADC integrates analog input and reference buffers for increased input impedance and includes a two-channel multiplexer. Absolute accuracy is achieved via one-time or continuous calibration modes. The device also operates with a variety of supply configurations while drawing less than 330 μ A.

The CS5541 includes two digital filters. The first filter which achieves simultaneous rejection of 50/60 Hz provides single conversion settling at 13.4 SPS throughput or four conversion settling at 53.7 SPS throughput. The second filter which achieves 16-bit performance provides single conversion settling at 64.8 SPS throughput or four conversion settling at 260 SPS throughput. (Either filter's output word rates can be increased by using a faster master clock, up to 40 kHz).

To ease communication between the ADCs and a microcontroller, the converters include a simple three-wire serial interface which is SPI and Mi-

crowire compatible. A Schmitt Trigger input is provided on the serial clock (SCLK) input.

2.1 Analog Input

Figure 4 illustrates a block diagram of the CS5541. The device consists of a multiplexer, a unity gain coarse/fine charge input buffer, a fourth order Δ - Σ modulator, and a digital filter.

2.1.1 Analog Input Model

Figure 5 illustrates the input models for the AIN pins. The model includes a coarse/fine charge buffer which reduces the dynamic current demand on the analog input signal. The buffer is designed to accommodate rail to rail (common-mode plus signal) input voltages. Typical CVF (sampling) current is about 12 nA (MCLK = 32.768 kHz). Application Note 30, "Switched-Capacitor A/D Input Structures", details various input architectures.

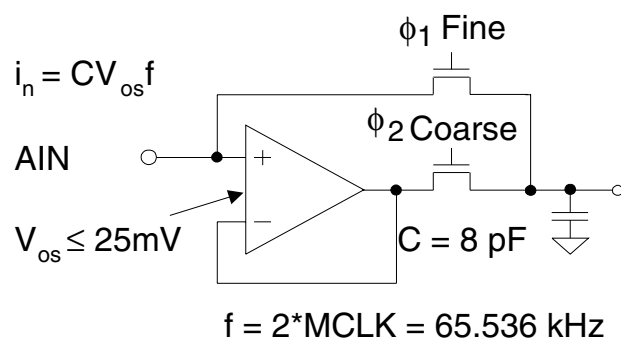

Figure 5. Input model for AIN+ and AIN- pins.

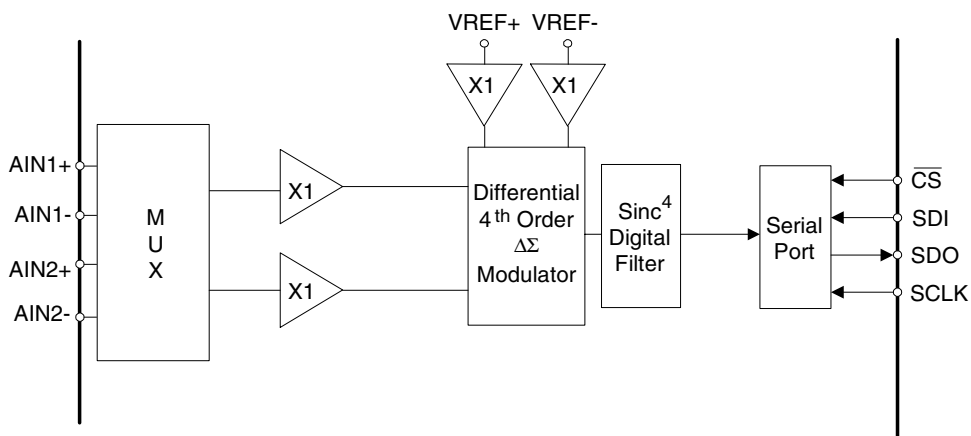

Figure 4. Multiplexer Configuration.

2.2 Voltage Reference Input

The differential voltage between VREF+ and VREF- sets the nominal full scale input range of the converter. For a single-ended reference voltage, the reference output is connected to the VREF+ pin of the CS5541 and the ground reference is connected to the VREF- pin. Note that the differential reference voltage can be from 0.1 V to ((VA+)-(VA-)). The noise-free resolution of a single sample from the ADC is directly proportional to the voltage reference as depicted in Figures 6 and 7.

Note: When a lower reference voltage is used, the resulting code widths are smaller. Since the output codes exhibit more changing codes for a fixed amount of noise, the converter appears noisier.

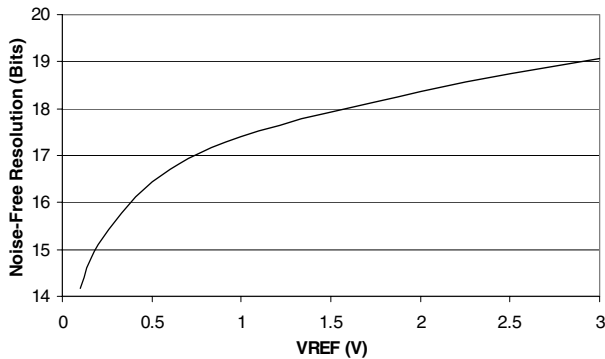

Figure 6. Typical Noise-Free Resolution vs. Voltage Reference

One-Time Cal, 4 Cycle Settling, 50/60 Hz Reject
 Noise-Free Res. = \log_2 (Bipolar Span/6.6*RMS Noise)

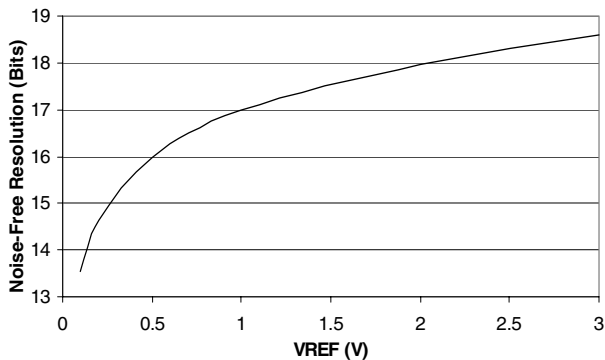

Figure 7. Typical Noise-Free Resolution vs. Voltage Reference

Continuous Cal, 1Cycle Settling, 50/60 Hz Reject
 Noise-Free Res. = \log_2 (Bipolar Span/6.6*RMS Noise)

2.2.1 Voltage Reference Input Model

Figure 8 illustrates the input models for the VREF pins. It includes a coarse/fine charge buffer which reduces the dynamic current demand on the external reference. The reference's buffer is designed to accommodate rail-to-rail (common-mode plus signal) input voltages. Typical CVF (sampling) current is about 20 nA (MCLK = 32.768 kHz; see Figure 8).

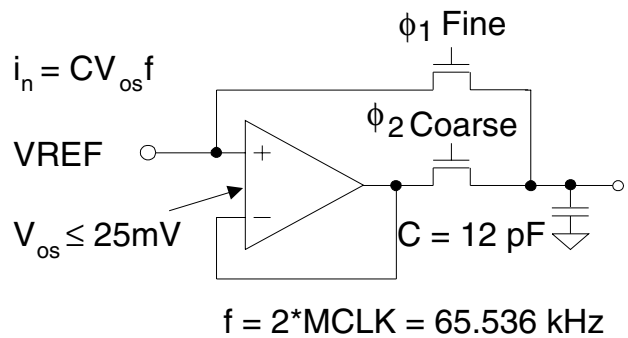

Figure 8. Input model for VREF+ and VREF- pins.

2.3 Power Supply Arrangements

The CS5541 is designed to operate with a total supply voltage of $3.0\text{ V} \pm 5\%$. For maximum flexibility separate pins are provided for VA+, VA-, VD+, and DGND, which is especially useful with ground referenced input signals.

Figure 9 illustrates the CS5541 connected with a single +3.0 V supply for both the analog and digital sections.

2.4 Clock Generator

The CS5541 includes an oscillator circuit which can be connected with an external crystal to provide the master clock for the chip. The chip is designed to operate using a low-cost 32.768 kHz “tuning fork” type crystal. One lead of the crystal should be connected to OSC1 and the other to OSC2. A 10 Megohm resistor should be connected in parallel with the crystal. Lead lengths should be minimized to reduce stray capacitance. The converter will operate with an external (CMOS com-

patible) clock applied at OSC1 with frequencies up to 40 kHz.

2.5 Serial Port Interface

The CS5541’s serial interface consists of four control lines: $\overline{\text{CS}}$, SDI, SDO, and SCLK.

$\overline{\text{CS}}$, Chip Select, is the control line which enables access to the serial port. If the $\overline{\text{CS}}$ pin is tied to logic 0, the port will function as a three wire interface.

SDI, Serial Data In, is the data signal used to transfer data to the converters.

SDO, Serial Data Out, is the data signal used to transfer output data from the converters. The SDO output will be held at high impedance any time $\overline{\text{CS}}$ is at logic 1.

SCLK, Serial Clock, is the serial bit-clock which controls the shifting of data to or from the ADC’s serial port. The $\overline{\text{CS}}$ pin must be held at logic 0 before SCLK transitions can be recognized by the port logic. To accommodate opto-isolators SCLK is designed with a Schmitt-trigger input.

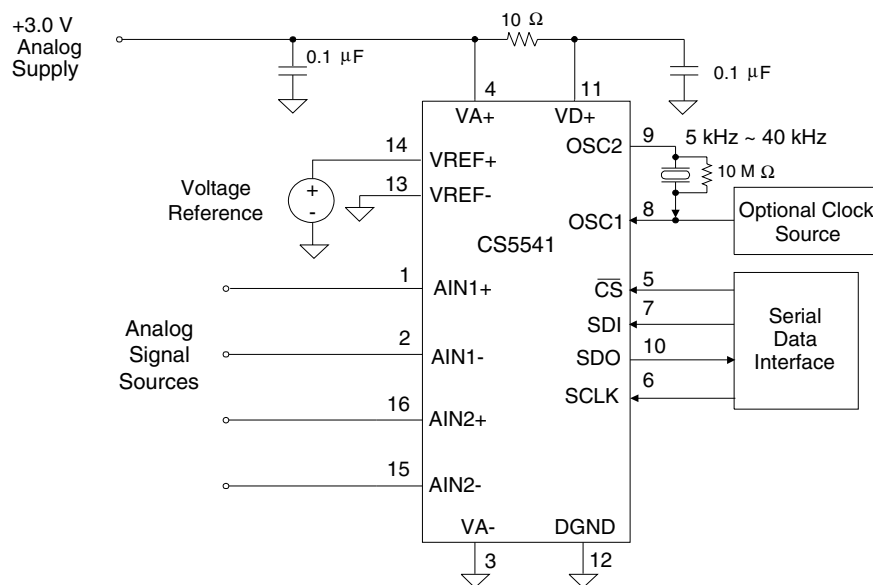

Figure 9. CS5541 Configured with +3.0 V Analog Supply.

2.6 Serial Port

The CS5541 includes a state machine with an 8-bit command register, which instructs the ADC to perform conversions, and a 24-bit conversion data register (read only) to store conversion results. Figure 10 illustrates a block diagram of the internal registers.

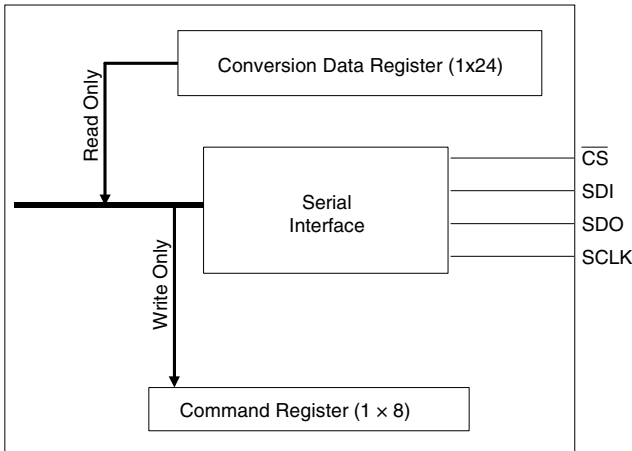

Figure 10. CS5541 Register Diagram.

After power is applied to the ADC (the ADC includes a power-on reset circuit) or after the user transmits the serial port initialization sequence, the serial port is set to the command mode. The converter stays in this mode until a valid 8-bit command is received (the first 8 bits into the serial port). Once a valid 8-bit data mode command is received and interpreted by the ADC's command register, the serial port enters the data mode and continuous conversions are performed. The SDO

pin falls at the end of a conversion and the user may read the conversion data by providing 32 serial clocks (SCLKs), as shown in Figure 11. The first 8 SCLKs are needed to clear the SDO flag and to read the status flags. During the next 24 SCLKs, the conversion data is shifted out of the serial port. To continue performing the conversions, SDI must be kept low during the status read time. A new command can be issued any time other than during the data read. If the command happens to be a power save command, the serial port goes back to the command mode. Otherwise, the conversions will stop in progress and start new conversions based on the information in the command byte, and the serial port will remain in the data mode. Section 2.8, "Command Register Quick Reference", lists all valid commands.

2.7 Serial Port Initialization Sequence

To initialize the serial port of the ADC to the command mode, the user can transmit the serial port initialization sequence. The port initialization sequence involves clocking seven (or more) SYNC1 command bytes (0xFF) followed by one SYNC0 command byte (0xFE). Note that this sequence places the ADC's serial port in the command mode where it waits until a valid command is received. This sequence does not reset the internal registers to their default settings. Further note that the sequence can be issued at any time and aids significantly in initial code development.

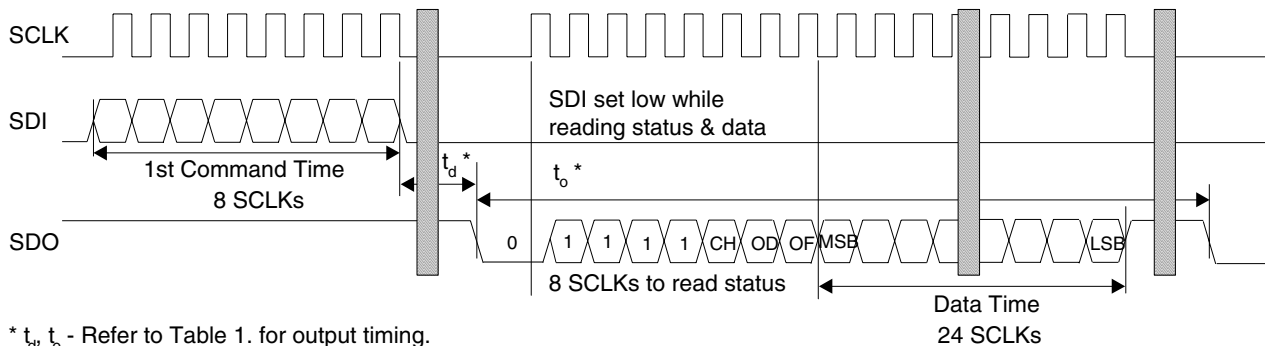

* t_d , t_o - Refer to Table 1. for output timing.

Figure 11. Command and Data Word Timing.

2.8 Command Register Quick Reference

D7(MSB)	D6	D5	D4	D3	D2	D1	D0
CB	CH	PS	U/B	FS1	FS0	C1	C0

BIT	NAME	VALUE	FUNCTION
D7	Command Bit, CB	0	Reserved
		1	Logic 1 for executable commands
D6	Channel Select, CH	0	Activate AIN1 for conversion
		1	Activate AIN2 for conversion
D5	Power Save, PS Notes 23, 24	0	Data Mode
		1	Power Save Mode (Standby or Sleep)
D4	Unipolar/Bipolar, U/B	0	Bipolar Conversion Mode
		1	Unipolar Conversion Mode
D3-D2	Filter Select, FS1-FS0 Note 25	00	Single Cycle Settling, 50/60 Hz Reject
		01	Single Cycle Settling, No 50/60 Hz Reject
		10	Four Cycle Settling, 50/60 Hz Reject
		11	Four Cycle Settling, No 50/60 Hz Reject
D1-D0	Conversion Calibration Select, C1-C0	00	Calibrate prior to each point
		01	Perform a one time calibration
		10	Use default calibration coefficients for conversions
		11	Use existing calibration coefficients for conversion

- Notes: 23. After entering a Power Save Mode, the user must wait a minimum of 2 system clocks before issuing a convert command.
24. A Power Save Mode cannot be entered by selectively setting the D5 bit. 0xAX must be written to the command register before the Sleep Mode will be enabled. Similarly, 0xBX must be written to the command register before the Standby Mode will be enabled.
25. If Four Cycle Settling is selected (D3 = '1'), the part will perform a one-time calibration when continuous calibration is chosen.

2.9 Performing Conversions/Calibrations

The CS5541 offers four conversion/self-calibration modes (if a user requires system calibration, this can be accommodated in the system microcontroller). The first mode allows the user to calibrate continuously between each conversion. The second mode allows the user to calibrate once after the command is issued and then continuously convert on the channel selected using the calibration result. The third mode allows the user to skip calibration; however, it performs conversions with the default calibration coefficients. The final mode allows the user to use the previous calibration coefficients to perform continuous conversions on the channel selected. The sections that follow detail the differences between the conversion modes. The sections also explain how to decode the conversion word into the respective flag and data bits.

2.9.1 Continuous Calibrations and Conversions (reduced output rate)

This mode performs an offset and gain calibration prior to each conversion. Note that the effective throughput in this mode is reduced by two as a calibration is performed prior to each conversion. Nevertheless, after the first command instructing the ADC to enter this mode is given, an offset calibration is performed followed by a gain calibration. Then the first data conversion is performed. Subsequent conversions are offset calibration followed by data conversion. Then, a gain calibration is performed followed by a data conversion. The ADC repetitively steps through this sequence until a new command is issued.

Note: The CS5541 offers self calibration where the ADC calibrates out offset and gain errors due to the ADC itself. Calibration in the CS5541 is used to set the zero and gain slope of the ADC's transfer function. For the self-calibration of offset, the converter

internally ties the inputs of the modulator together and routes them to the VREF- pin as shown in Figure 12. VREF- must be tied to a fixed voltage between VA+ and VA-. For self-calibration of gain, the differential inputs of the modulator are connected to VREF+ and VREF- as shown in Figure 13. Further note that each calibration step (offset or gain) takes one conversion cycle to complete. However, after the ADC is reset, it is functional and can perform measurements without being calibrated (see Perform Continuous Conversions with Default Calibration Coefficients section for details). In this case, the converter will utilize the initialized values of the on-chip registers (Offset = 0, Gain = 1.0) to calculate output words. Any initial offset and gain errors in the internal circuitry of the chip will remain.

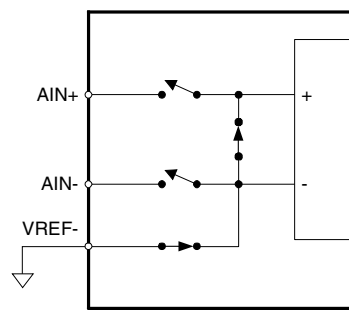

Figure 12. Self Calibration of Offset.

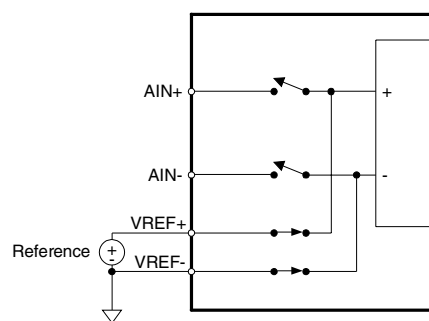

Figure 13. Self Calibration of Gain.

2.9.2 One Time Calibration followed by Continuous Conversions

After the first command instructing the ADC to enter this mode is given, an offset calibration is performed followed by a gain calibration. Then the first data conversion is performed. Subsequent conversions do not include new calibrations. This allows the ADC to provide maximum throughput for the filter rate selected.

2.9.3 Continuous Conversions with Default Calibration Coefficients

After the command instructing the ADC to enter this mode is given, the ADC will utilize the initialized values of the on-chip calibration registers (Offset = 0, Gain = 1.0) for all conversions. This allows the ADC to provide maximum throughput for the filter rate selected. This mode is recommended when the user is performing a system calibration.

2.9.4 Continuous Conversions with Existing Calibration Coefficients

After the command instructing the ADC to enter this mode is given, the ADC will use the coefficients from the previous calibration to calculate conversions. If no prior calibration has been performed since power-up, the ADC will use the default calibration coefficients (Offset = 0, Gain = 1). The ADC performs conversions at the maximum throughput for the filter rate selected.

2.9.5 Output Word Timing

Table 1 describes the output word timing of the CS5541. D3-D0 are the last four bits of the command word issued, as described in Section 2.8. Both t_d and t_o are represented graphically in Figure 11. t_d represents the amount of time for a conversion to be completed, once a valid command is received. t_o is the time required for all subsequent conversions, before a new command is received. “Throughput” is the rate at which those subsequent conversions are output.

D3-D0	t_d - First Output (cycles) Note 26	t_o - Subsequent Outputs (cycles)	Throughput (SPS) Note 27
0000	7358	4884	6.7093
0001	7358	2442	13.418
001x	2474	2442	13.418
0100	1550	1012	32.379
0101	1550	506	64.759
011x	538	506	64.759
100x	7358	610	53.718
101x	2474	610	53.718
110x	1550	126	260.06
111x	538	126	260.06

Table 1. Filter Output Word Rates

Notes: 26. t_d can be off by one MCLK cycle if SCLK is asynchronous to MCLK.

27. Throughput calculations assume that MCLK = 32.768 kHz.

2.9.6 System Calibration

If a system level calibration is to be performed using a system microcontroller, it is best to put the converter in the *Continuous Conversions with Default Calibration Coefficients* mode. The user would configure the system with a zero-level input and store the resulting conversion for system offset correction. Then the user would configure the system with a full-scale input level and store the resulting conversion for system full-scale correction. Correction of converter data is then performed using the system microcontroller.

2.9.7 Reading Conversions

At the completion of a conversion, SDO will fall to logic 0 to indicate that the conversion is complete. If calibration modes are used they will be transparent to user and only affect the effective throughput of the ADC. Nevertheless, to read a conversion word, the user must issue 8 SCLKs (SDI = logic 0 for the NULL command and remain in this mode or SDI can be used to clock in a new command) to clear the SDO flag and read the status flags. Upon the falling edge of the 8th SCLK, the SDO pin will present the first bit (MSB) of the conversion word. 24 SCLKs (high, then low) are then required to read the conversion word from the port. Upon the falling edge of the 32nd SCLK, SDO will return high, waiting till the next conversion is complete before it falls again.

When operating in any of the conversion modes, the user need not read every conversion. If the user chooses not to read a conversion after SDO falls, SDO will rise one MCLK clock cycle before the next conversion is completed and then fall to signal that another conversion word is available. To exit the particular conversion mode, the user must issue any valid command, other than the NULL command, to the SDI input. The new command can be issued anytime other than during the data read. If the user wants to read the last conversion data and issue the new command, the following protocol is

required: After SDO falls, read the status flags (keeping SDI low, 8 SCLKs), followed by the conversion data (24 SCLKs). Then follow it up with the new command at SDI (8 SCLKs).

If the command happens to be a power save command, the serial port goes back to the command mode. Otherwise, the conversion will stop in progress and start new conversions based on the information in the command byte, and the serial port remains in the data mode.

Note:

- 1) If the user begins to clear the SDO end-of-conversion flag and read the conversion data, this action must be finished before the conversion cycle which is occurring in the background is complete if the user wants to be able to read the new conversion data.
- 2) If a new conversion command is issued to the converter while it is performing a conversion, the filter will stop the current conversion and start a new convolution cycle to perform a new conversion.
- 3) If a new conversion command is issued when SDO is low, SDO will output 01111, then CH, OD, and OF. Afterwards, SDO will remain high until one MCLK cycle before the new data is ready, then fall to indicate that the conversion is completed.

2.9.8 Output Coding

The CS5541 outputs 24-bit data conversion words. To read a conversion word the user must read the conversion data register. The conversion data register is 24 bits long and outputs the data word MSB first. Once a conversion is complete, SDO falls and 32 SCLK's are required to read the results. The first 8 SCLKs are used to clear the SDO flag and clock out the status flags.

The Channel Indicator (CH) bit keeps track of which input channel was converted.

The Oscillation Detect (OD) bit is set to a logic 1 any time that an oscillatory condition is detected in the modulator. This does not occur under normal operating conditions, but may occur whenever the input to the converter is extremely overranged. If the OD bit is set, the conversion data bits can be completely

erroneous. The OD flag bit will be cleared to logic 0 when the modulator becomes stable.

The Overrange Flag (OF) bit is set to a logic 1 any time the input signal is: 1) more positive than positive full scale, 2) more negative than zero (unipolar mode), 3) more negative than negative full scale (bipolar mode). It is cleared back to logic 0 whenever a conversion word occurs which is not over-ranged.

The last 24 SCLKs are used to clock data out of the conversion data register.

Table 2 and Table 3 illustrate the output coding for the CS5541. Unipolar conversions are output in binary format and bipolar conversions are output in two's complement format.

2.9.9 Digital Filter

The CS5541 includes two digital filters. The first filter which achieves simultaneous rejection of 50/60 Hz provides single conversion settling at

13.4 SPS throughput or four conversion settling at 53.7 SPS throughput. The second filter which achieves 16-bit performance provides single conversion settling at 64.8 SPS throughput or four conversion settling at 260 SPS throughput.

The first filter (13.4 SPS and 53.7 SPS throughput) is optimized to yield better than 80 dB rejection between 47 Hz to 63 Hz (i.e. 80 dB minimum rejection for both 50 Hz and 60 Hz) when the master clock is 32.768 kHz. The filter has a response as shown in Figure 14.

The second filter is optimized for higher throughput, and does not provide 50 Hz or 60 Hz rejection. It has a frequency response that is shown in Figure 15.

To ease code development, each filter (13.4 SPS or 64.8 SPS throughput) has a mode that only outputs fully settled output conversions (every 4th convolution).

				D31	D30	D29	D28	D27	D26	D25	D24
				0	1	1	1	1	CH	OD	OF
D23	D22	D21	D20	D19	D18	D17	D16	D15	D14	D13	D12
MSB	22	21	20	19	18	17	16	15	14	13	12
D11	D10	D9	D8	D7	D6	D5	D4	D3	D2	D1	D0
11	10	9	8	7	6	5	4	3	2	1	LSB

Table 2. Output Conversion Data Register Description (24 bits + flags)

Unipolar Input Voltage	Offset Binary	Bipolar Input Voltage	Two's Complement
>(VFS-1.5 LSB)	FFFFFF	>(VFS-1.5 LSB)	7FFFFFF
VFS-1.5 LSB	FFFFFF ----- FFFFFFE	VFS-1.5 LSB	7FFFFFF ----- 7FFFFFFE
VFS/2-0.5 LSB	800000 ----- 7FFFFFF	-0.5 LSB	000000 ----- FFFFFFF
+0.5 LSB	000001 ----- 000000	-VFS+0.5 LSB	800001 ----- 800000
<(+0.5 LSB)	000000	<(-VFS+0.5 LSB)	800000

Table 3. CS5541 24-Bit Output Coding

Note: VFS in the table equals the voltage between ground and full scale for the unipolar mode, or the voltage between ± full scale for the bipolar mode. See text about error flags under overrange conditions.

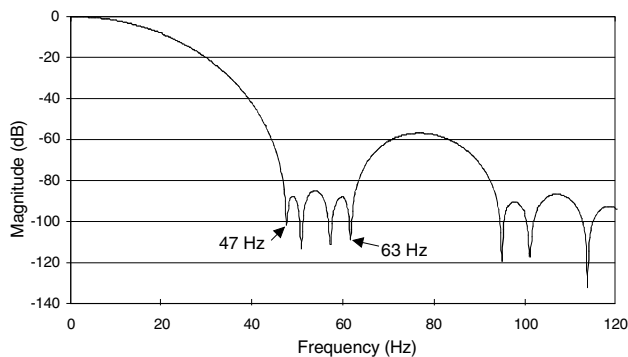

Figure 14. Filter 1 Response (MCLK = 32.768 kHz)

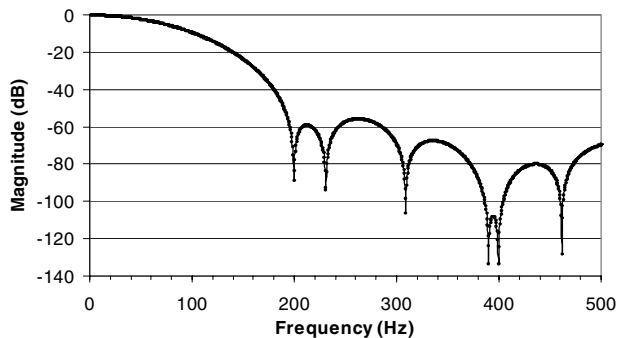

Figure 15. Filter 2 Response (MCLK = 32.768 kHz)

To accommodate higher throughput requirements, each filter has a mode (53.7 SPS or 260 SPS throughput) that outputs every single convolution. This allows users to see input signal trends at higher update rates.

Note: The converter's digital filter characteristics linearly scale with MCLK.

2.10 Sleep and Standby Modes

The CS5541 accommodates three power consumption modes: normal, sleep, and standby. The normal power consumption mode is entered by default after a power-on-reset. In this mode, the CS5541 typically consumes 750 μ W.

The Sleep Mode is entered whenever the sleep command, 0xAX, is issued to the serial port. The ADC immediately enters sleep after the command is issued, reducing the consumed power to around 30 μ W. During sleep, most of the analog portion of the chip is powered down and filter convolutions are halted. To exit sleep (i.e. to return to normal power consumption mode), the user must transmit

a data mode command. Since the sleep mode disables the oscillator, approximately a 500 ms crystal oscillator start-up delay period is required before the ADC returns to the normal power consumption mode. Note that if an external clock is used, the ADC will return to normal power mode within 3 milliseconds.

The Standby Mode is entered by writing 0xBX to the part. The Standby Mode performs the same function as the Sleep Mode except that the oscillator is not powered down. This eliminates the crystal oscillator start-up time, with a return to normal power within 3 milliseconds. Again, to exit standby (i.e. to return to normal power consumption mode), the user must transmit a data mode command. The power during Standby will be around 75 μ W.

2.11 Power-Up Sequence and Initialization

Care must be taken to assure that no pins are ever taken below the negative analog supply (VA-) potential. The analog and digital supplies should be applied simultaneously to assure that the power-on reset circuit will automatically reset the ADC when both supplies are at acceptable levels.

Commands should not be sent to the ADC until a stable clock is present. If a 32.768 kHz crystal is being used, it will take approximately 500 ms for the oscillator to stabilize after power has been applied to the converter. If a CMOS compatible source with no start-up delay is used, then the ADC is immediately ready for a command.

After a valid reset, the ADC is placed into the command state where it waits for a valid command to execute. Once a valid conversion command has been received, conversions will begin and data can be read using the serial port.

Note: The CS5541 includes an on-chip power-on reset circuit to automatically reset the ADC shortly after power-up. When power to the CS5541 is applied, the ADC is held in a reset condition until the master clock has started and a counter-timer elapses (i.e. the counter-timer counts 490 MCLK cycles to

make sure the oscillator is fully stable). In normal start-up conditions, this power on reset circuit should reset the chip when power is applied. If your application could experience abnormal power start-up conditions, it is recommended that the serial port reinitialization sequence, followed by a power save command, be performed to guarantee that the converter begins proper operation.

2.12 PCB Layout

The CS5541 should be placed entirely over an analog ground plane with the DGND pin of the device connected to the analog ground plane. Place the analog-digital plane split immediately adjacent to the digital portion of the chip

See the CDB5540/41 data sheet for suggested layout details and Applications Note 18 for more detailed layout guidelines.

Applications Engineering provides a free and confidential Schematic Review Service.



3. PIN DESCRIPTIONS

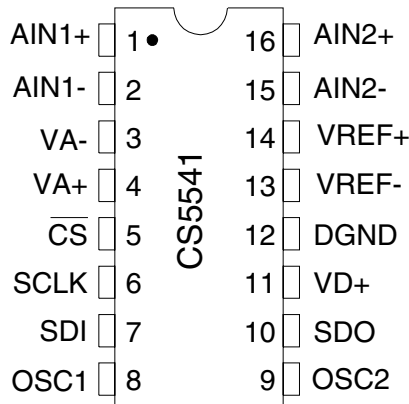

Clock Generator

OSC1; OSC2 - Master Clock.

An inverting amplifier inside the chip is connected between these pins and can be used with a crystal to provide the master clock for the device. Alternatively, an external (CMOS compatible) clock (powered relative to VD+) can be supplied into the OSC1 pin to provide the master clock for the device.

Control Pins and Serial Data I/O

$\overline{\text{CS}}$ - Chip Select.

When active low, the port will recognize SCLK. When high the SDO pin will output a high impedance state. $\overline{\text{CS}}$ should be changed when SCLK = 0.

SDI - Serial Data Input.

SDI is the input pin of the serial input port. Data will be input at a rate determined by SCLK.

SDO - Serial Data Output.

SDO is the serial data output. It will output a high impedance state if $\overline{\text{CS}} = 1$.

SCLK - Serial Clock Input.

A clock signal on this pin determines the input/output rate of the data for the SDI/SDO pins respectively. This input is a Schmitt trigger to allow for slow rise time signals. The SCLK pin will recognize clocks only when $\overline{\text{CS}}$ is low.

Measurement and Reference Inputs**AIN1+, AIN1-, AIN2+, AIN2- - Differential Analog Input.**

Differential input pins into the device.

VREF+, VREF- - Voltage Reference Input.

Fully differential inputs which establish the voltage reference for the on-chip modulator.

Power Supply Connections**VA+ - Positive Analog Power.**

Positive analog supply voltage.

VA- - Negative Analog Power.

Negative analog supply voltage.

VD+ - Positive Digital Power.

Positive digital supply voltage.

DGND - Digital Ground.

Digital Ground.

4. SPECIFICATION DEFINITIONS

Linearity Error

The deviation of a code from a straight line which connects the two end points of the A/D Converter transfer function. One end point is located 1/2 LSB below the first code transition and the other end point is located 1/2 LSB beyond the code transition to all ones. Units in percent of full-scale.

Differential Nonlinearity

The deviation of a code's width from the ideal width. Units in LSBs.

Full Scale Error

The deviation of the last code transition from the ideal $[(V_{REF+}) - (V_{REF-})] - 3/2 \text{ LSB}$. Units are in LSBs.

Unipolar Offset

The deviation of the first code transition from the ideal (1/2 LSB above the voltage on the AIN- pin). When in unipolar mode ($\overline{U/B}$ bit = 1). Units are in LSBs.

Bipolar Offset

The deviation of the mid-scale transition (111...111 to 000...000) from the ideal (1/2 LSB below the voltage on the AIN- pin). When in bipolar mode ($\overline{U/B}$ bit = 0). Units are in LSBs.

16L SSOP PACKAGE DRAWING

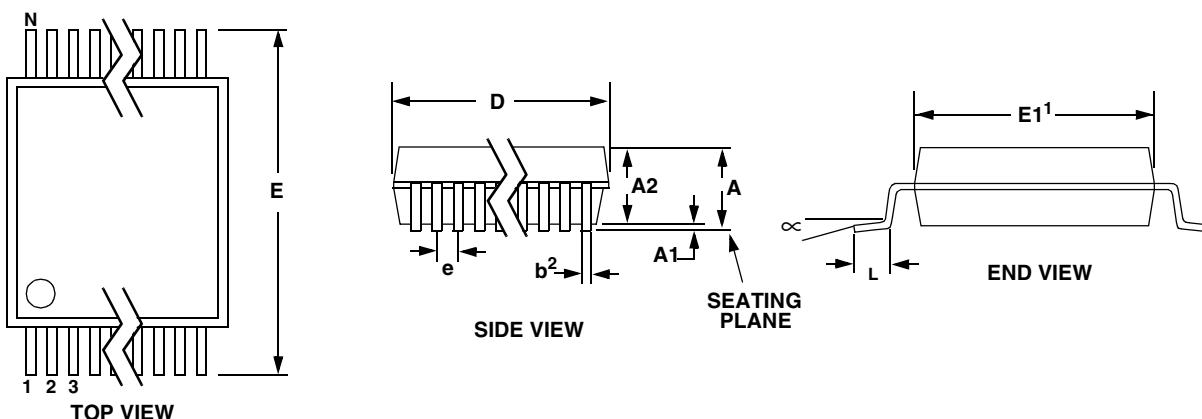

DIM	INCHES			MILLIMETERS			NOTE
	MIN	NOM	MAX	MIN	NOM	MAX	
A	--	--	0.084	--	--	2.13	
A1	0.002	0.005	0.010	0.05	0.13	0.25	
A2	0.064	0.069	0.074	1.68	1.75	1.88	
b	0.009	0.012	0.015	0.22	--	0.38	2,3
D	0.232	0.244	0.256	5.90	6.20	6.50	1
E	0.291	0.307	0.323	7.40	7.80	8.20	
E1	0.197	0.209	0.220	5.00	5.30	5.60	1
e	0.022	0.026	0.030	0.55	0.65	0.75	
L	0.025	0.0295	0.041	0.63	0.75	1.03	
∞	0°	4°	8°	0°	4°	8°	

JEDEC #: MO-150

- Notes:
1. "D" and "E1" are reference datums and do not include mold flash or protrusions, but do include mold mismatch and are measured at the parting line, mold flash or protrusions shall not exceed 0.20 mm per side.
 2. Dimension "b" does not include dambar protrusion/intrusion. Allowable dambar protrusion shall be 0.13 mm total in excess of "b" dimension at maximum material condition. Dambar intrusion shall not reduce dimension "b" by more than 0.07 mm at least material condition.
 3. These dimensions apply to the flat section of the lead between 0.10 and 0.25 mm from lead tips.

• **Notes** •

SMART
Analog™