

- 1N5711UR-1 AVAILABLE IN JAN, JANTX, JANTXV and JANS PER MIL-PRF-19500/444
- 1N5712UR-1 AVAILABLE IN JAN, JANTX, JANTXV and JANS PER MIL-PRF 19500/445
- SCHOTTKY BARRIER DIODES
- LEADLESS PACKAGE FOR SURFACE MOUNT
- METALLURGICALLY BONDED, DOUBLE PLUG CONSTRUCTION

1N5711UR-1 CDLL5711  
 1N5712UR-1 CDLL5712  
 1N6857UR-1 CDLL6263  
 1N6858UR-1 CDLL6857  
 CDLL2810 CDLL6858

## MAXIMUM RATINGS

Operating Temperature: -65°C to +150°C  
 Storage Temperature: -65°C to +150°C  
 Operating Current: 5711 & 6263 TYPES :33mA dc @  $T_{EC} = +140^{\circ}C$   
 2810, 5712 & 6858 Types :75mA dc @  $T_{EC} = +130^{\circ}C$   
 6857 Types :150mA dc @  $T_{EC} = +110^{\circ}C$   
 Derating: :All Types: Derate to 0 (zero) mA dc @ +150°C

## ELECTRICAL CHARACTERISTICS @ 25°C, unless otherwise specified.

CDI TYPE NUMBER	MINIMUM BREAKDOWN VOLTAGE	MAXIMUM FORWARD VOLTAGE	MAXIMUM FORWARD VOLTAGE	MAXIMUM REVERSE LEAKAGE CURRENT		MAXIMUM CAPACITANCE @ $V_R = 0$ VOLTS $f = 1.0$ MHz	ESDS CLASS
	$V_{BR} @ 10 \mu A$	$V_F @ 1 mA$	$V_F @ I_F$	$I_R @ V_R$		$C_T$	
	VOLTS	VOLTS	VOLTS@mA	NA	VOLTS	PICO FARADS	
1N5711UR-1	70	0.41	1.0 @ 15	200	50	2.0	1
1N5712UR-1	20	0.41	1.0@35	150	16	2.0	1
1N6857UR-1	20	0.35	0.75@35	150	16	4.5	2
1N6858UR-1	70	0.36	0.65 @ 15	200	50	4.5	2
CDLL2810	20	0.41	1.0 @ 35	100	15	2.0	1
CDLL5711	70	0.41	1.0 @ 15	200	50	2.0	1
CDLL5712	20	0.41	1.0 @ 35	150	16	2.0	1
CDLL6263	60	0.41	1.0 @ 15	200	50	2.2	1
CDLL6857	20	0.35	0.75 @ 35	150	16	4.5	2
CDLL6858	70	0.36	0.65 @ 15	200	50	4.5	2

**NOTE:** Effective Minority Carrier Lifetime ( $\tau$ ) is 100 Pico Seconds

**NOTICE:** Qualification testing to J, JX, JV and JS levels for 6857 and 6858 types is underway. Contact the factory for qualification completion dates. These two part numbers are being introduced by CDI as "drop-in" replacements for the 5711 and 5712. They provide a more robust mechanical design and a higher ESDS class with the only trade-off being an increase in capacitance.

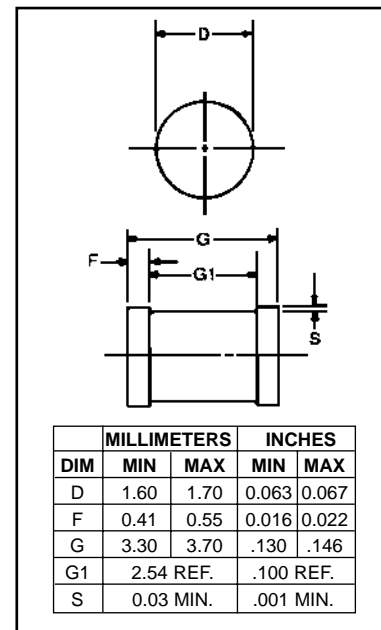

FIGURE 1

## DESIGN DATA

**CASE:** DO-213AA, Hermetically sealed glass case. (MELF, SOD-80, LL34)

**LEAD FINISH:** Tin / Lead

**THERMAL RESISTANCE:** ( $R_{\theta JC}$ ):  
100 °C/W maximum at L = 0 inch

**THERMAL IMPEDANCE:** ( $Z_{\theta JX}$ ): 40 °C/W maximum

**POLARITY:** Cathode end is banded.

**MOUNTING SURFACE SELECTION:**  
The Axial Coefficient of Expansion (COE) Of this Device is Approximately +6PPM/°C. The COE of the Mounting Surface System Should Be Selected To Provide A Suitable Match With This Device.



**COMPENSATED DEVICES INCORPORATED**

22 COREY STREET, MELROSE, MASSACHUSETTS 02176  
 PHONE (781) 665-1071 FAX (781) 665-7379  
 WEBSITE: <http://www.cdi-diodes.com> E-mail: [mail@cdi-diodes.com](mailto:mail@cdi-diodes.com)

# 1N5711UR-1, 1N5712UR-1, 1N6857UR-1, 1N6858UR-1, CDLL5711, CDLL5712, CDLL2810, CDLL6263, CDLL6857 and CDLL6858

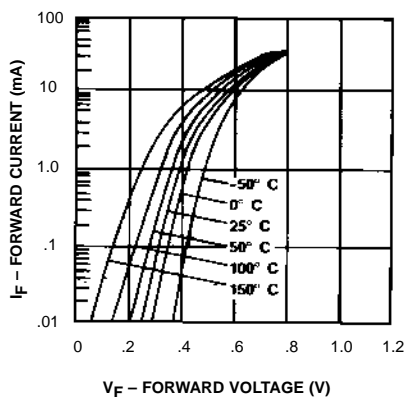

**Figure 1.**  
I-V Curve Showing Typical Forward Voltage Variation with Temperature for the CDLL2810 and CDLL5712 Schottky Diodes.

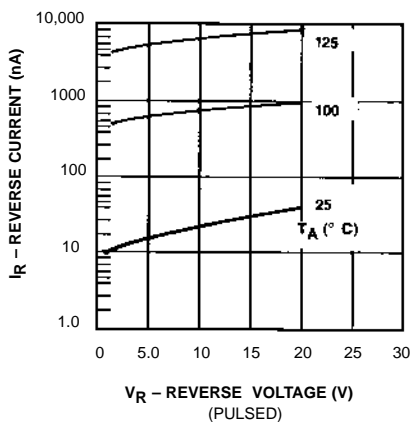

**Figure 2.**  
CDLL2810 and CDLL5712 Typical Variation of Reverse Current ( $I_R$ ) vs. Reverse Voltage ( $V_R$ ) at Various Temperatures.

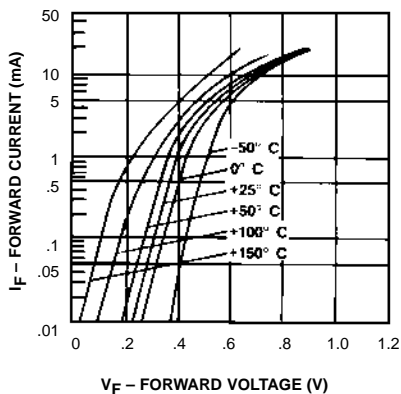

**Figure 3.**  
I-V Curve Showing Typical Forward Voltage Variation with Temperature for Schottky Diode CDLL5711.

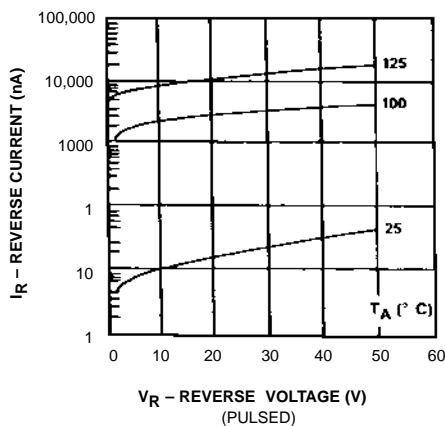

**Figure 4.**  
CDLL5711 Typical Variation of Reverse Current ( $I_R$ ) vs. Reverse Voltage ( $V_R$ ) at Various Temperatures.

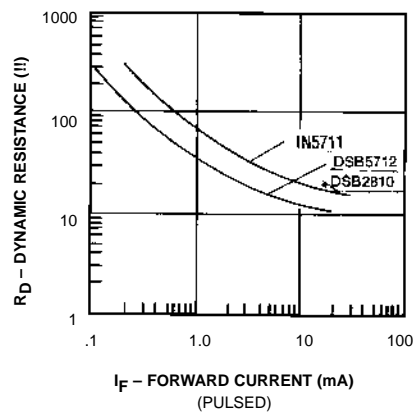

**Figure 5.**  
Typical Dynamic Resistance ( $R_D$ ) vs. Forward Current ( $I_F$ ).