

Solid State Relays PCB, 1-Phase ZS Types RAP 40 A ., RAP 48 A .

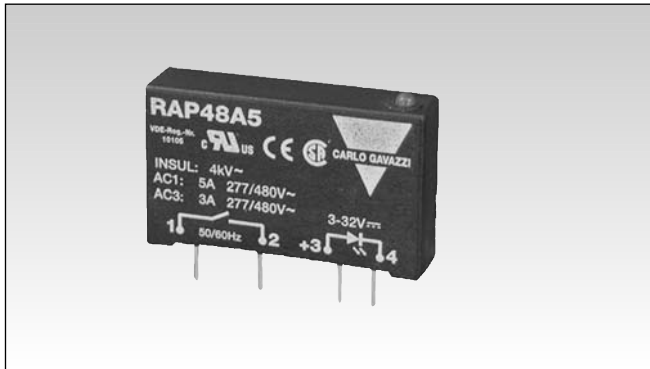

- AC Solid State Relay for PCB mounting
- Zero switching
- Rated operational current: 3 or 5 AACrms
- Non-repetitive voltage: Up to 1200 V_p
- Rated operational voltage: Up to 480 VACrms
- Input range: 3.5 to 40 VDC
4.5 to 40 VDC
- Insulation: OPTO (input-output) 4000 VACrms
- LED status indication
- Low off-state leakage current
- High surge ratings

Product Description

The RAP-series from Carlo Gavazzi is a Solid State Relay family for socket- or PCB-mounting. With built-in LED status indication for control input, the relay is an ideal interface between PLC's or other logic controls and load. The housing design and packing allows automatic insertion and soldering.

The relay has been designed to switch inductive or resistive loads as long as enough attention is paid to the specifications stated in this data

sheet, e.g. max. current, ambient temperature etc.

The use of optotriacs for galvanic separation together with alternistors as output devices give the most advanced performance. Additional snubbers are no longer necessary. The zero switching relay also works with inductive loads due to its high surge capability. An internal heatsink optimizes the thermal resistance between chip and ambient air, thereby increasing the lifetime of the relay.

Ordering Key

RAP 48 A 5

- Solid State Relay (PCB)
- Switching mode
- Mounting type
- Rated operational voltage
- Housing type
- Rated operational current

Type Selection

Switching mode	Rated operational voltage	Rated operational current	Control voltage
A: Zero switching	40: 400 VACrms 48: 480 VACrms	3: 3 AACrms 5: 5 AACrms	3.5 to 40 VDC 4.5 to 40 VDC

Selection Guide

Rated operational voltage	Control voltage	Rated operational current 3 AACrms	5 AACrms
400 VACrms	3.5 to 40 VDC	RAP 40 A 3	RAP 40 A 5
480 VACrms	4.5 to 40 VDC	RAP 48 A 3	RAP 48 A 5

General Specifications

	RAP 40 A .	RAP 48 A .
Operational voltage range	10 to 440 VACrms	20 to 530 VACrms
Non-rep. peak voltage	≥ 1000 V _p	≥ 1200 V _p
Zero voltage turn-on	≤ 20 V	≤ 40 V
Operational frequency range	45 to 65 Hz	45 to 65 Hz
Power factor	≤ 0.2	≤ 0.2
Approvals	UL, CSA, VDE	UL, CSA, VDE
CE-marking	Yes	Yes

Input Specifications

	RAP 40 A .	RAP 48 A .
Control voltage range	3.5 to 40 VDC	4.5 to 40 VDC
Pick-up voltage	3.5 VDC	4.5 VDC
Drop-out voltage	1 VDC	2 VDC
Reverse voltage	6 VDC	6 VDC
Response time pick-up	≤ 1/2 cycle	≤ 1/2 cycle
Response time drop-out	≤ 1/2 cycle	≤ 1/2 cycle
Input current (through current limiter)	≤ 12 mA	≤ 12 mA

Output Specifications

	RAP 4.. A 3	RAP 4.. A 5
Rated operational current AC 51 AC 53a	3 AACrms 2.5 AACrms	5 AACrms 3 AACrms
Minimum operational current	20 mAACrms	20 mAACrms
Rep. overload current t=1 s	≤ 6 AACrms	≤ 12 AACrms
Non-rep. surge current t=20 ms	60 A _p	90 A _p
Off-state leakage current @ rated voltage and frequency	≤ 1 mAACrms	≤ 1 mAACrms
I ² t for fusing t=1-10 ms	≤ 18 A ² s	≤ 40 A ² s
On-state voltage drop @ rated current	≤ 1.2 VACrms	≤ 1.2 VACrms
Critical dV/dt off-state	≥ 100 V/μs	≥ 100 V/μs

Thermal Specifications

	RAP .. A 3	RAP .. A 5
Operating temperature	-20° to +70°C (-4 to +158°F)	-20° to +70°C (-4 to +158°F)
Storage temperature	-40° to +100°C (-40° to +212°F)	-40° to +100°C (-40° to +212°F)
Junction temperature	≤ 125°C (257°F)	≤ 125°C (257°F)
R _{th} junction to case	≤ 20.5 K/W	≤ 15.6 K/W
R _{th} junction to ambient	≤ 33 K/W	≤ 21 K/W

Insulation Input - Output

Rated insulation voltage	≥ 4000 VACrms
Insulation resistance	≥ 10 ¹⁰ Ω
Insulation capacitance	≤ 8 pF
Reference voltage according to VDE 01 10 B Insulation group C	500 VACrms, 600 VDC

Wiring Diagram

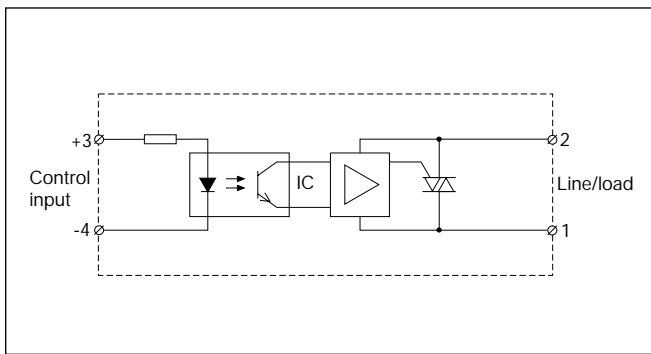

Functional Diagram

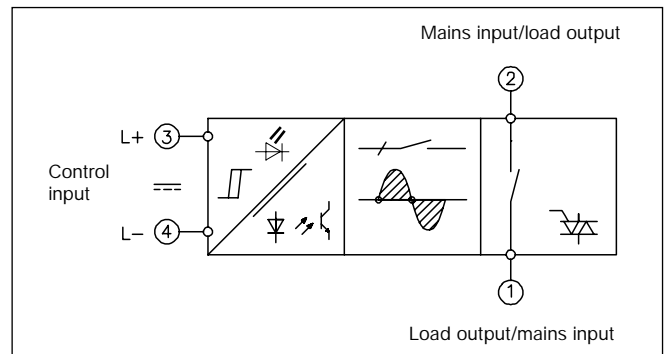

Derating Curve

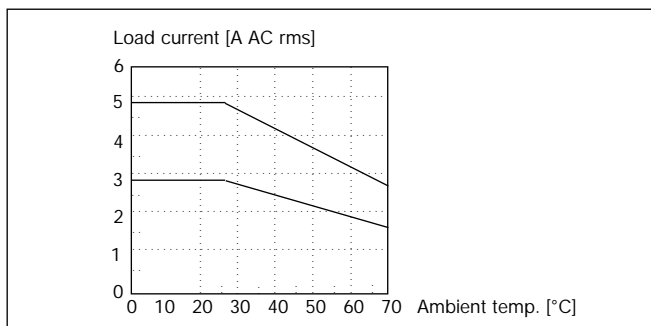

Applications

These relays can be used to switch heaters, motors, lights, valves or solenoids. When used at full load current, the relays must be placed vertically. If more than one relay is mounted, please allow a minimum distance of 20 mm between for sufficient air cooling.

Housing Specifications

Weight	Approx. 10 g
Housing material	Noryl GFN 1, black
Terminals	Copper, tin-plated
Potting compound	Flame-retardant polyurethane

Dimensions

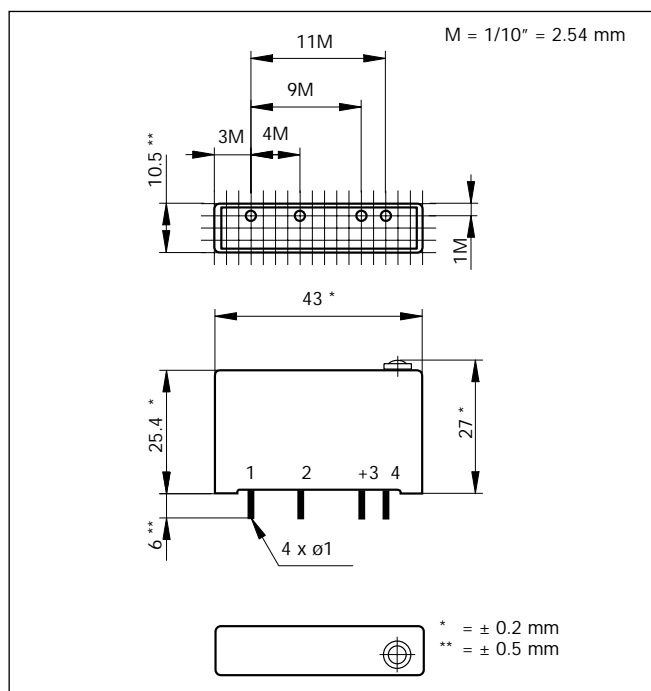

Accessories

Varistors
 Fuses
 For further information refer to "General Accessories".