

# Timers Interval Types B 101, B 201, B 108, B 208



- Time ranges: 0.15 s to 600 s
- Automatic start
- Knob-adjustable time within range
- Oscillator-controlled time circuit
- Repeatability deviation:  $\leq 1\%$
- Output: 10 A SPDT or 8 A DPDT relay
- Plug-in type module
- Scantimer housing
- LED-indication for relay on
- AC or DC power supply

## Product Description

Mono-function, plug-in miniature interval time relays up to 600 s (10 min) covering 3 individual time ranges. This economical timer is often used in applications such as lubricating pumps, drying elements, etc. where an operation is wanted to last for a longer period of time.

## Ordering Key

**B 108 024 600**

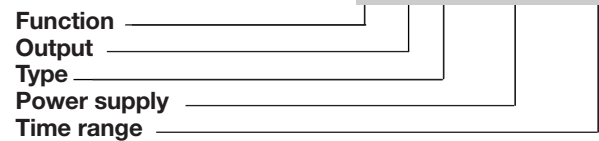

## Type Selection

Plug	Output	Time ranges	Supply: 24 VAC/DC	Supply: 120 VAC	Supply: 220 VAC
Circular 8 pin	SPDT	0.15 - 6 s	B 108 024 006	B 108 120 006	B 108 220 006
		1.5 - 60 s	B 108 024 060	B 108 120 060	B 108 220 060
		15 - 600 s	B 108 024 600	B 108 120 600	B 108 220 600
Circular 11 pin		0.15 - 6 s	B 101 024 006	B 101 120 006	B 101 220 006
		1.5 - 60 s	B 101 024 060	B 101 120 060	B 101 220 060
		15 - 600 s	B 101 024 600	B 101 120 600	B 101 220 600
Circular 8 pin	DPDT	0.15 - 6 s	B 208 024 006	B 208 120 006	B 208 220 006
		1.5 - 60 s	B 208 024 060	B 208 120 060	B 208 220 060
		15 - 600 s	B 208 024 600	B 208 120 600	B 208 220 600
Circular 11 pin		0.15 - 6 s	B 201 024 006	B 201 120 006	B 201 220 006
		1.5 - 60 s	B 201 024 060	B 201 120 060	B 201 220 060
		15 - 600 s	B 201 024 600	B 201 120 600	B 201 220 600

## Time Specifications

<b>Time ranges</b>	0.15- 6 s 1.5 - 60 s 15 - 600 s	<b>Repeatability deviation</b>	$\leq 1\%$
<b>Time range accuracy</b>	0 to +10% on max. min. actual time $\leq$ min. set time	<b>Time variation</b> Within rated power supply and ambient temperature	$\leq 0.05\%/V$ $\leq 0.2\%/^{\circ}C$
		<b>Reset</b> Time and/or relay	Power supply interruption $\geq 250$ ms



## Output Specifications

	B 108, B 101	B 208, B 201
<b>Output</b>	SPDT relay	DPDT relay
Basic electrical insulation	250 VAC (rms) (contact/electronics)	250 VAC (rms) (contacts/elec., contact/contact)
<b>Contact ratings (AgCdO)</b>	μ (micro gap)	μ (micro gap)
Resistive loads	AC 1 10 A/250 VAC (2500 VA) DC 1 1 A/250 VDC (250 W) or 10 A/25 VDC (250 W)	8 A/250 VAC (2000 VA) 0.4 A/250 VDC (100 W) 4 A/25 VDC (100 W)
Small inductive loads	AC 15 2.5 A/230 VAC DC 13 5 A/24 VDC	2.5 A/230 VAC 5 A/24 VDC
<b>Mechanical life</b>	≥ 30 x 10 <sup>6</sup> operations	≥ 30 x 10 <sup>6</sup> operations
<b>Electrical life</b>	AC 1 ≥ 2.5 x 10 <sup>5</sup> operations (at max. load)	≥ 2.5 x 10 <sup>5</sup> operations (at max. load)
<b>Operating frequency</b>	≤ 7200 operations/h	≤ 7200 operations/h
<b>Insulation voltages</b>		
Rated insulation voltage	≥ 2.0 kVAC (rms) (contact/electronics)	≥ 2.0 kVAC (rms) (contact/electronics)
Rated transient protection volt.	4 kV (1.2/50 μs) (contact/electronics) (IEC 60664)	4 kV (1.2/50 μs) (contact/electronics) (IEC 60664)

## Supply Specifications

<b>Power supply AC types</b>	Installation cat. III
Rated operational voltage through pins 2 & 10 or pins 2 & 7	220 220 VAC + 15/- 20%, 45 to 65 Hz 120 120 VAC + 15/- 20%, 45 to 65 Hz 024 24 VAC + 15/- 20%, 45 to 65 Hz
Drop-out tolerance	≥ 10 ms
Rated insulation voltage	None
Rated transient protection volt.	4 kV (1.2/50 μs) @ 220 VAC 2.5 kV (1.2/50 μs) @ 120 VAC 800 V (1.2/50 μs) @ 24 VAC (line/neutral)
<b>Power supply DC type</b>	Installation cat. III
Rated operational voltage 024	24 VDC + 15/- 20% (pin 2 pos.)
Rated insulation voltage	None
Rated transient protection volt.	800 V (1.2/50 μs)
<b>Consumption</b>	
AC supply	60 mA @ 50 Hz/70 mA @ 60 Hz
DC supply	1 W

## General Specifications

<b>Power ON delay</b>	≤ 200 ms
<b>Power OFF delay</b>	≥ 250 ms
<b>Indication for Output ON</b>	LED. red
<b>Environment</b>	IP 20 B
Pollution degree	2 (IEC 60664)
Operating temperature	-20° to +50°C (-4° to +122°F)
Storage temperature	-50° to +85°C (-58° to +185°F)
<b>Weight</b>	85 g
<b>Approvals</b>	UL, CSA

## Mode of Operation

The relay operates and the time period starts when power supply is applied to the time relay.

At the end of the set delay, the relay releases and will not operate again until power supply is reapplied.

A recovery period of 250 ms should be allowed before re-applying power supply.

If power supply is interrupted for more than 250 ms before the time period has expired, the relay releases and the time is reset to zero.

## Wiring Diagrams

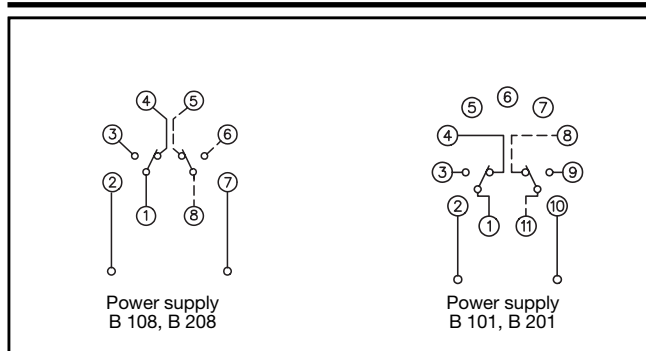



## Time Setting

---

Knob-adjustable on scale in seconds.

## Accessories

---

Sockets◊	S 408, S 411
Hold down spring◊	HF
Mounting rack	SM 13
Socket cover	BB 4
Potentiometer lock	PL 1

For further information refer to "Accessories".

## Operation Diagram

---

