

FEATURES

- Industry Standard Footprint
- Single Isolated Output
- Short Circuit Protection
- Operating Temperature Range -40°C to +85°C
- Low Profile 24 Pin Case
- Efficiency to 82%
- Power Density 0.90W/cm³
- 2:1 Wide Input Range
- 5V, 12V, 24V & 48V Input
- 3.3V, 5V, 9V, 12V & 15V Output
- Footprint 4.73cm²
- UL 94V-0 Package Materials
- No Heatsink Required
- Internal SMD Construction
- Fully Encapsulated
- Lead Free Compatible

DESCRIPTION

The NDY series is a range of low profile DC/DC converters offering a single regulated output over a 2:1 input voltage range. All parts deliver 3W output power up to 85°C without heatsinking, except the 4.5V to 9V input voltage range which should be derated to 2W at the lower input voltage. A flyback oscillator design with isolated feedback is used to give regulation over the full operating range of 25% to 100% of full load. It is strongly recommended that external capacitors be used on input and output to guarantee performance over full load and input voltage range (see recommended filter circuit for values). The plastic case and encapsulant materials are rated to UL 94V-0 and the connection pins are formed from a tin plated alloy 42 leadframe.

Order Code	Nominal Input Voltage (V)	Rated Output Voltage (V)	Output Current ⁴		Input Current Full Load (mA)	Min Efficiency ¹ (%)	Typical Isolation Capacitance (pF)	MTTF ³ (kHrs)
			Min Load (mA)	Full Load (mA)				
NDY0505	5	5	100-150	400-600	615	66	40	1939
NDY0509	5	9	55-83	222-333	563	72	52	1926
NDY0512	5	12	42-62	166-250	548	71	43	1907
NDY0515	5	15	33-50	133-200	533	73	44	1924
NDY1205	12	5	150	600	362	71	36	1928
NDY1209	12	9	83	333	320	78	52	1916
NDY1212	12	12	62	250	316	78	44	1897
NDY1215	12	15	50	200	308	79	47	1914
NDY2403	24	3.3	227	909	178	70	30	1671
NDY2405	24	5	150	600	174	70	36	1673
NDY2409	24	9	83	333	156	78	52	1663
NDY2412	24	12	62	250	154	80	44	1644
NDY2415	24	15	50	200	150	82	54	1657
NDY4803	48	3.3	227	909	87	71	30	1676
NDY4805	48	5	150	600	87	73	35	1668
NDY4809	48	9	83	333	78	80	52	1663
NDY4812	48	12	62	250	77	81	44	1648
NDY4815	48	15	50	200	76	81	53	1661

INPUT CHARACTERISTICS					
Parameter	Conditions	MIN	TYP	MAX	Units
Voltage Range	All NDY05XX	4.5	5	9	VDC
	All NDY12XX	9	12	18	
	All NDY24XX	18	24	36	
	All NDY48XX	36	48	72	
Reflected ¹ Ripple Current	NDY2403 ²		180	360	mA p-p
	NDY4803 ²		140	290	
	All NDY05XX		400	500	
	All NDY12XX		150	170	
	All other NDY24XX		290	360	
	All other NDY48XX		100	127	

ABSOLUTE MAXIMUM RATINGS	
Short-circuit protection	continuous
Input voltage 05 types	10V
Input voltage 12 types	20V
Input voltage 24 types	40V
Input voltage 48 types	80V
Lead temperature 1.5mm from case for 10 seconds	300°C
Minimum Load	25% of rated load
Internal Dissipation	1.7W

1 Measured at full load with external input/output capacitors, refer to filter circuit 1.
 2 For lower ripple refer to filter circuit 2.
 3 Calculated using MIL-HDBK-217F with nominal input voltage at full load.
 4 Refer to power derating graph.
 All specifications typical at T_A=25°C, nominal input voltage and rated output current unless otherwise specified.

OUTPUT CHARACTERISTICS					
Parameter	Conditions	MIN	TYP	MAX	Units
Voltage Set Point Accuracy	With external input/output capacitors, refer to filter circuits		±1	±5	%
Line Regulation	Low line to high line, 3.3V output with external input/output capacitors, refer to filter circuit 1		0.05	0.2	%
	Low line to high line, with external input/output capacitors, refer to filter circuit 1		0.05	0.5	%
Load Regulation	25% load to 100% load, 3.3V output with external input/output capacitors, refer to filter circuit 1		0.6	0.5	%
	25% load to 100% load, with external input/output capacitors, refer to filter circuit 1		0.2	0.5	%
Ripple ²	BW = 20Hz to 300kHz. 3.3V output with external input/output capacitors, refer to filter circuit 1		80	120	mV rms
	BW = 20Hz to 300kHz. With external input/output capacitors, refer to filter circuit 1		5	10	mV rms
Noise	BW = DC to 100MHz. 3.3V output with external input/output capacitors, refer to filter circuit 1			180	mV p-p
	BW = DC to 100MHz. With external input/output capacitors, refer to filter circuit 1		50	100	mV p-p

ISOLATION CHARACTERISTICS					
Parameter	Conditions	MIN	TYP	MAX	Units
Isolation Test Voltage	Flash tested for 1 second	1000			VDC
Resistance	Viso=500VDC	1			GΩ

GENERAL CHARACTERISTICS					
Parameter	Conditions	MIN	TYP	MAX	Units
Switching Frequency	100% load V _{IN} nominal 3.3V output	160		220	kHz
	25% load V _{IN} nominal 3.3V output	290		560	
	100% load V _{IN} nominal	80		220	
	25% load V _{IN} nominal	290		560	

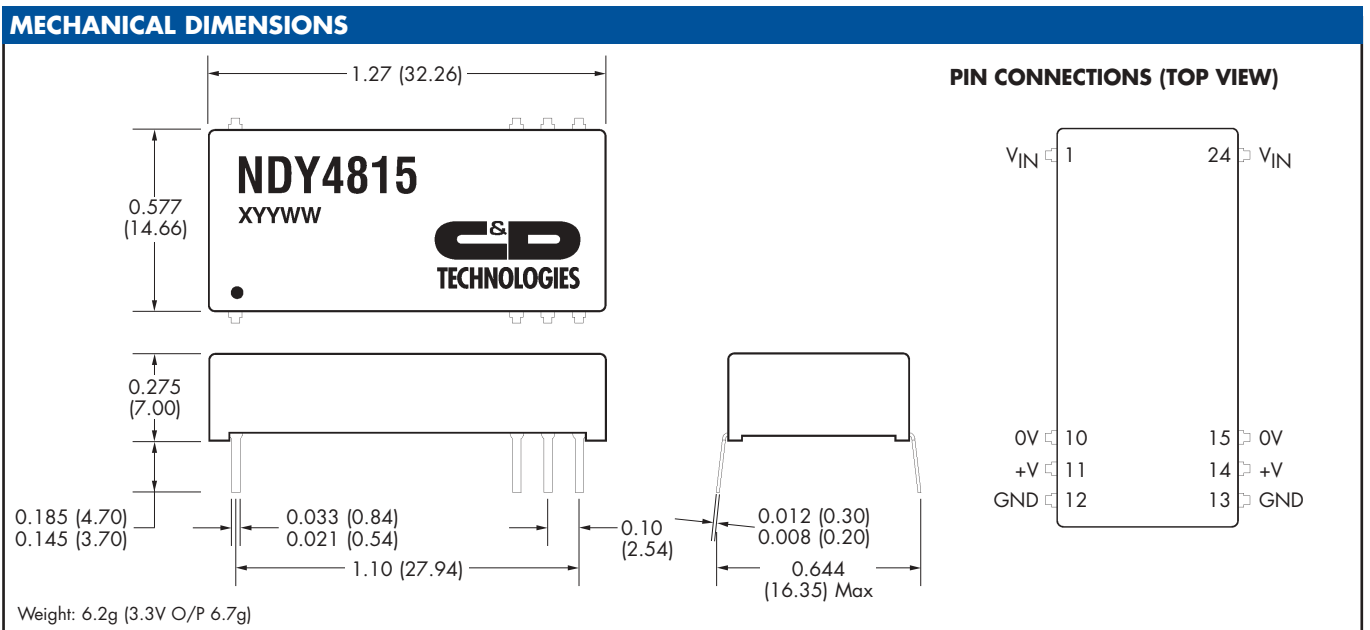

1 Measured at full load with external input/output capacitors, refer to filter circuit 1.
 2 For lower ripple refer to filter circuit 2.
 3 Calculated using MIL-HDBK-217F with nominal input voltage at full load.
 4 Refer to power derating graph.
 All specifications typical at T_A=25°C, nominal input voltage and rated output current unless otherwise specified.

FILTER CIRCUITS

EXTERNAL CAPACITANCE

Although these converters will work without external capacitors, they are necessary in order to guarantee the full parametric performance over the full line and load range. All parts have been tested and characterised using the following values and test circuit.

OUTPUT LOAD

The minimum rated load across the whole input voltage range is 25% of the full load output. It is important to take care that the load does not fall below this as the output ripple will greatly increase. While this condition will not harm the device the resultant increase in output ripple could cause customers' application to malfunction.

Value		
C _{IN}	C _{OUT}	L _{OUT}
10µF, 200V Philips Part Number 151621809 or any good low esr capacitor	100µF, 25V Philips Part Number 13556101 or any good low esr capacitor	C&D Technologies Part No 24100

FILTER CIRCUIT 1

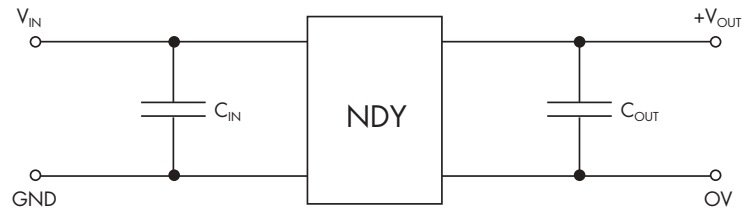

FILTER CIRCUIT 2 Recommended circuit for reduced ripple 3.3V O/P

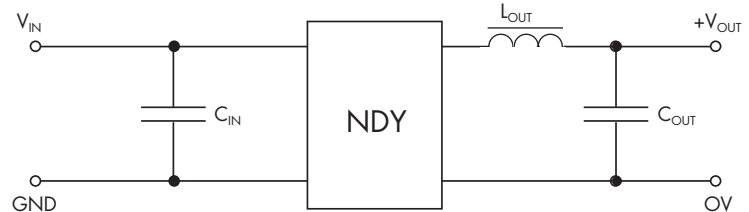

ENVIRONMENTAL

Parameter	Conditions	MIN	TYP	MAX	Units
Operation		-40		85	°C
Storage		-50		130	°C
Cooling	Free air convection				

NDY05 POWER DERATING CURVE

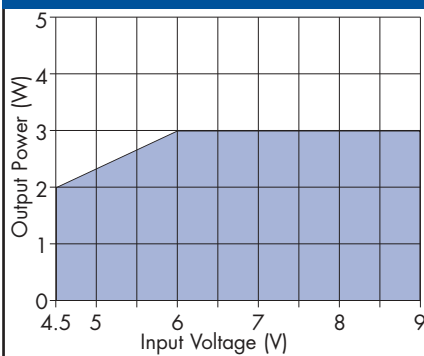

C&D Technologies (NCL) Limited reserve the right to alter or improve the specification, internal design or manufacturing process at any time, without notice. Please check with your supplier or visit our web site to ensure that you have the current and complete specification for your product before use.

© C&D Technologies (NCL) Limited 2003

NDC NDY.3

No part of this publication may be copied, transmitted or stored in a retrieval system or reproduced in any way including, but not limited to, photography, photocopy, magnetic or other recording means, without prior written permission from C&D Technologies (NCL) Limited.

Instructions for use are available from www.cdpoweronline.com

C&D Technologies (NCL) Ltd
Tanners Drive, Blakelands North
Milton Keynes MK14 5BU, England
Tel: +44 (0)1908 615232
Fax: +44 (0)1908 617545
email: info@cdtechno-ncl.com

www.cdpoweronline.com

C&D Technologies Inc.
3400 E Britannia Drive, Tucson,
Arizona 85706, USA
Tel: +1 (800) 547-2537
Fax: +1 (520) 741-4598
email: sales@cdtechno.com