

2.5 Gb/s Transmitter Module - DWDM, 100 GHz

The MT25EW transmitter module provides an easy to use self-contained optical source for Dense Wavelength Division Multiplexed (DWDM) applications up to 2.7 Gb/s data rates. The module requires +5 V, +3.3 V, 0 V supplies and PECL/ECL data input to operate, and so allows non-DWDM optical links to be upgraded very easily. Internal control circuitry, including Etalon wavelength locking, ensures that the optical source remains within optical power and wavelength limits over variations in temperature, power, and over life. The MT25EW conforms to ITU-T G.692, ITU-T G.957, G.958 STM-16 Long Haul and Telcodia OC-48 Long Reach specifications for data links to 160 Km and beyond. Over 40 wavelengths are available, specified as per the ITU grid at 100 GHz channel spacing, covering the C-band EDFA window.

Features

- Up to 2.7 Gb/s
- ITU 100 GHz grid compliant
- 0 to +70°C operation
- High reliability optical components
- Optical link lengths to 3000 ps/nm & beyond
- Monitor functions for laser status
- Laser disable function and automatic mean power control
- Source wavelengths available covering the C-band EDFA window

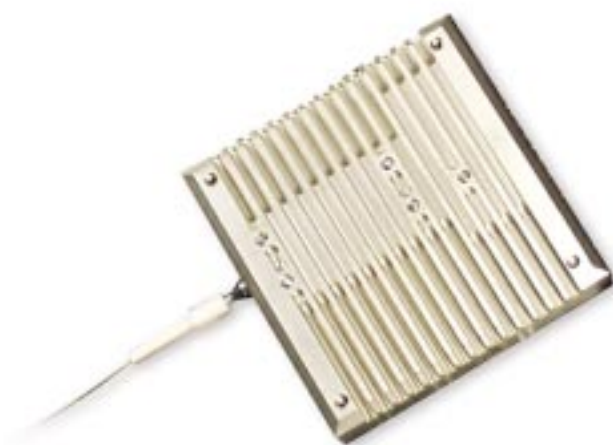

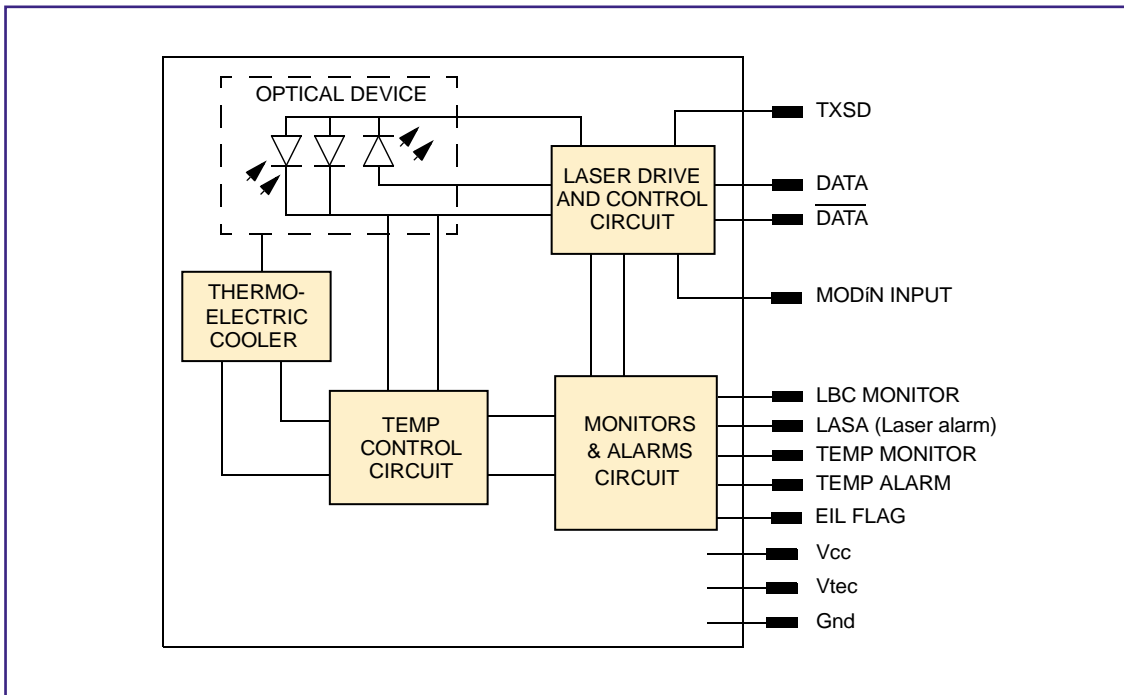

Figure 1: Transmitter block diagram

Functional description

The module comprises an hermetically packaged 1550 nm BH Laser device with optical isolation and **Etalon** wavelength feedback, laser drive, automatic laser power control, and monitoring circuitry.

The laser package uses a Thermo-Electric Cooler (TEC) to maintain the correct laser temperature to achieve constant lasing wavelength based on true wavelength feedback from the **Etalon** filter. The microprocessor based control circuit also provides temperature monitoring, alarm outputs and internal fault diagnostics.

The module features high speed complementary data inputs which are AC coupled and have internal 50 Ω termination, transmitter disable input, modulation input for wavelength tagging, alarm and monitor supervisory outputs, **Etalon** in lock output flag.

The optical output is via a single mode pigtail which can be fitted with a variety of single mode optical connectors.

The module operates from a 5 V supply, with 3.3 V supply for the TEC to minimise power dissipation. The module is very compact and incorporates an advanced integral heatsink.

Transmitter operation

Optical power control

The on board microprocessor provides fully automatic integrated power and wavelength control using the Etalon output signals as feedback. This approach enables a controlled start and inter-channel protection as well as normal constant power control.

Data input (\overline{DATA} , \overline{DATA})

The inputs are AC coupled and terminated with 50 Ω . This provides 100 Ω differential impedance. The recommended input signal must meet the required voltage swing for PECL/ECL. Due to the high speed nature of this product it is vital that high speed design rules are followed in the design of the system board. Follow the recommended user interfaces.

This transmitter is not suitable for burst mode operation and unbalanced data patterns may affect the automatic constant power circuit.

Transmitter operation (continued)

Transmitter disable (TXSD)

Transmitter operation can be disabled by applying a CMOS Logic 1 level to the TxSD pin. The laser can be disabled by the module microprocessor in the event of gross failure. When disabled the output power is < -40 dBm. In event of the microprocessor sets the Laser Alarm and the Temperature Alarm and maintains the transmitter disable until a power on reset.

Laser Bias Current Monitor (LBCM)

The LBCM provides an analog voltage output corresponding to the laser bias current. The LBCM output is referenced to ground and indicates the change of laser threshold as the laser ages. The LBCM output is buffered; use with high impedance loads to reduce errors and dissipation.

Laser alarm (LASA)

The Laser Alarm is an Active High CMOS level output. The Laser Alarm is active when the optical output power is outside of operations limits.

Temperature alarm

The temperature alarm is an active high CMOS level output. The temperature alarm is activated when the laser temperature is approximately 1°C above or below normal laser operating temperature for Etalon lock. This is a high current output and can drive alarms directly.

Etalon in lock flag (ELF)

This output provides an indication of when the wavelength is locked to the reference wavelength under **Etalon** control.

Modulation input (MODN)

The modulation input allows for the use of a low frequency tone (10-500 kHz) for modulation of the "1"s level. This input must be driven from a 50 Ω source, and is AC coupled internally. Do not exceed the maximum drive level. Over driving this input can cause waveform distortion; limit modulation depth to 5-10%. If unused, connect this input to 0 V to prevent noise pickup.

Two-wire interface (TWCK, TWDA)

The module can be configured using a two-wire communication interface. TWCK carries the clock signal generated by the external master. TWDA carries the serial data stream.

Power supplies

The module operates from a single rail power supply of +5.0 V nominal. The Thermo-Electric Cooler is supplied from a separate pin (Pin 11 Vtec). The TEC operates with a 3.3 V supply for a wide operating temperature range. This low voltage ability is used to reduce the power dissipation of the module.

Ensure the supply to the module is well filtered and as noise free as possible to prevent any possible interference with the module (see the recommended system interface). The supply feeds to the module and TEC must be of low DC impedance with minimal voltage drop at the maximum module and TEC currents. For maximum EMI screening, the case is electrically connected to the Gnd pins.

Pinout

Table 1: Module pinout

Pin #	Name	Pin #	Name
1	Gnd	20	Two-wire Data
2	$\overline{\text{Data}}$	19	Two-wire Clock
3	Data	18	Gnd
4	Gnd	17	Vcc
5	Laser Disable	16	Vtec
6	Vcc	15	Temperature Alarm
7	Vcc	14	No internal connection
8	Vcc	13	Laser Alarm
9	Modulation Input	12	Laser Bias Current Monitor
10	Gnd	11	Etalon in Lock Flag

Gnd pins are connected to the module case. Do not make any connection to pin 14.

Pins 19 & 20 can be connected to ground if not using the two wire interface.

Specification

Stresses beyond those in Table 2: “Absolute maximum ratings” may cause permanent damage to the module. These are stress ratings only and functional operation of the module at these or any other conditions beyond

those indicated in the operational sections of the specifications is not implied. Exposure to absolute maximum rating conditions for extended periods may affect the module’s reliability.

Table 2: Absolute maximum ratings

Parameter	Min	Max	Unit
Operating Case Temp	0	+70	°C
Shipping/storage Temp	-40	+85	°C
Relative Humidity		95	%RH
Applied Voltage(Any Pin)	-0.5	6.0	V
Lead Soldering Temp		250	C
Lead Soldering Time		10	S
Fibre Bend Radius	30		mm

Physical dimensions

Table 3: Fibre pigtail

Parameter	Min	Max	Unit
Bend Radius	30		mm
Mode Field Diameter	8.8	9.8	μm
Cladding Diameter	122	128	μm
Concentricity Error		0.5	μm
Pigtail Length (Typical) ¹	950	1050	mm

Note 1: Other pigtail Fibre lengths available on request

Mechanical outline

All dimensions in mm unless otherwise stated, general tolerance = 0.25 mm

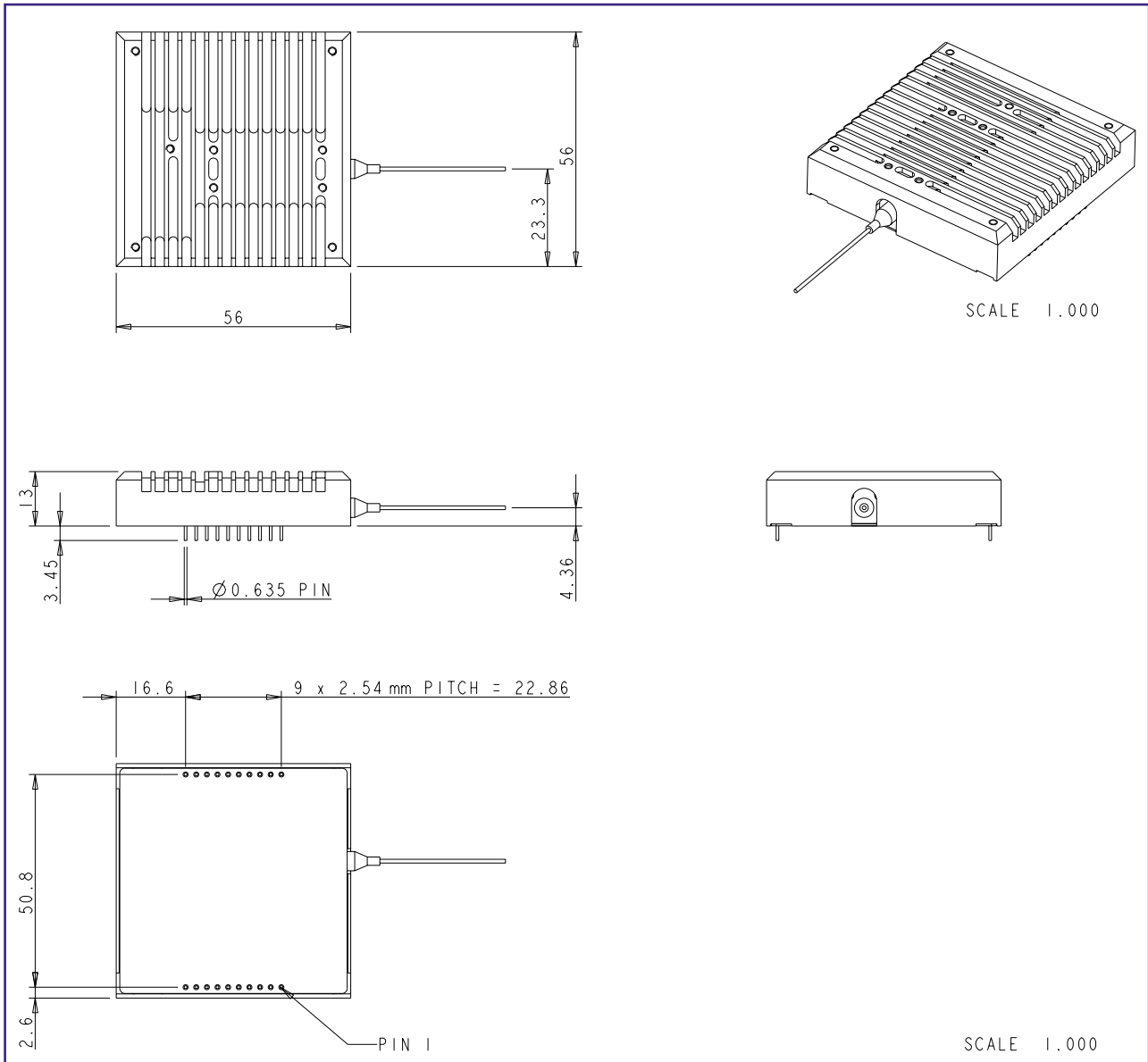

Figure 2: Mechanical outline

Electrical characteristics

The product is intended for use in fully compliant STM16 Long-haul optical links. These are defined by ITU-T G.957, G.958, and G.692. It is also intended for use in OC48 Long/Intermediate reach optical links as defined by Telcodia TA-NWT-000253. Table 4 shows the power supply requirements and digital data levels which must be met over temperature and life.

Typical parameters are RT/SOL, MIN and MAX values are over the operating temperature and power supply range.

Data input is 2.488 Gb/s 2^{23} -1 PRBS NRZ. PECL 10K

Table 4: Electrical characteristics

Parameter	Min	Typ	Max	Unit	Notes
Supply Voltage Vcc	4.7	5.0	5.3	V	
Supply Voltage Vtec	3.0	3.3	3.4	V	
Supply Current Icc		190	210	mA	
Supply Current Itec			1.4	A	
Transmitter Enable voltage	0		0.8	V	
Transmitter Disable voltage	3.6		Vcc	V	
Output Disable time			0.2	us	
Output Enable time			90	s	
Laser Bias Current Monitor	0		3.6	V	
LBC Monitor - Slope	35		45	mV/mA	
LBC Monitor -o/p current			1	mA	
Temperature Alarm Window	-1.0		+1.0	°C	
Temperature Alarm High	Vcc-0.7			V	
Temperature Alarm Low			0.6	V	
Etalon in Lock Flag High	Vcc-0.7			V	Note 4
Etalon in Lock Flag Low			0.6	V	Note 4
Laser Alarm - High	Vcc-1		Vcc	V	Note 1
Laser Alarm - Low	0		1	V	Note 1
Laser Alarm o/p current			10	mA	
Data Input Voltage	500	800	1000	mV	Pk-Pk
Data Input bit rate	0.155	2.488	2.7	Gb/s	Note 2
Modulation Voltage (RMS)	0		0.4	Vrms	Note 3
Modulation Input Frequency	10		500	KHz	

Note 1: Laser Alarm low under normal operating conditions.

Note 2: SONET/ITU compliance is at 2.488 Gb/s.

Note 3: Actual modulation depth obtained for a given input voltage varies between modules.

Note 4: In normal operation (Etalon in lock) the flag is high. Out of lock is indicated by a low level.

Optical characteristics

Typical parameters are RT/SOL, MIN and MAX values are over the operating temperature and power supply range.

Table 5: Optical characteristics

Parameter	Min	Typ	Max	Unit	Notes
Mean Output Power, SOL	+1.5	1.7	+2.5	dBm	Note 1
Mean Output Power, EOL	-0.5		+4.5	dBm	
Power Variation with Temp	-0.75		0.75	dB	
Wavelength	1527.22	-	1563.05	nm	Note 2
Wavelength Stability	-30		30	pm	
Spectral Width (-20dB)			1.0	nm	
Side Mode Suppression	30			dB	
Extinction Ratio	8.2			dB	
Optical rise/fall times		150		ps	Note 4
Dispersion Penalty			2.0	dB	Note 3

Note 1: Other mean powers available on request

Note 2: Compliant to ITU-T G692 100 GHz grid.

Note 3: Measured with 2^{23} 10e-10 over 3000 ps/nm fibre.

Note 4: Measured between 20% and 80% of rising/falling edge

Optical eye/jitter characteristics

The filtered optical eye obtained from the transmitter when driven with PRBS NRZ data must remain within the unshaded area of the SONET/SDH mask shown in Figure 3. A 4th Order Bessel Thompson with a 3dB point at 1.49 GHz is used to filter the incoming signal before applying the mask. "0.0" and "1.0" on the mask are normalised to "0" and "1" data levels of the optical output. See Table 5 for Optical Power Outputs.

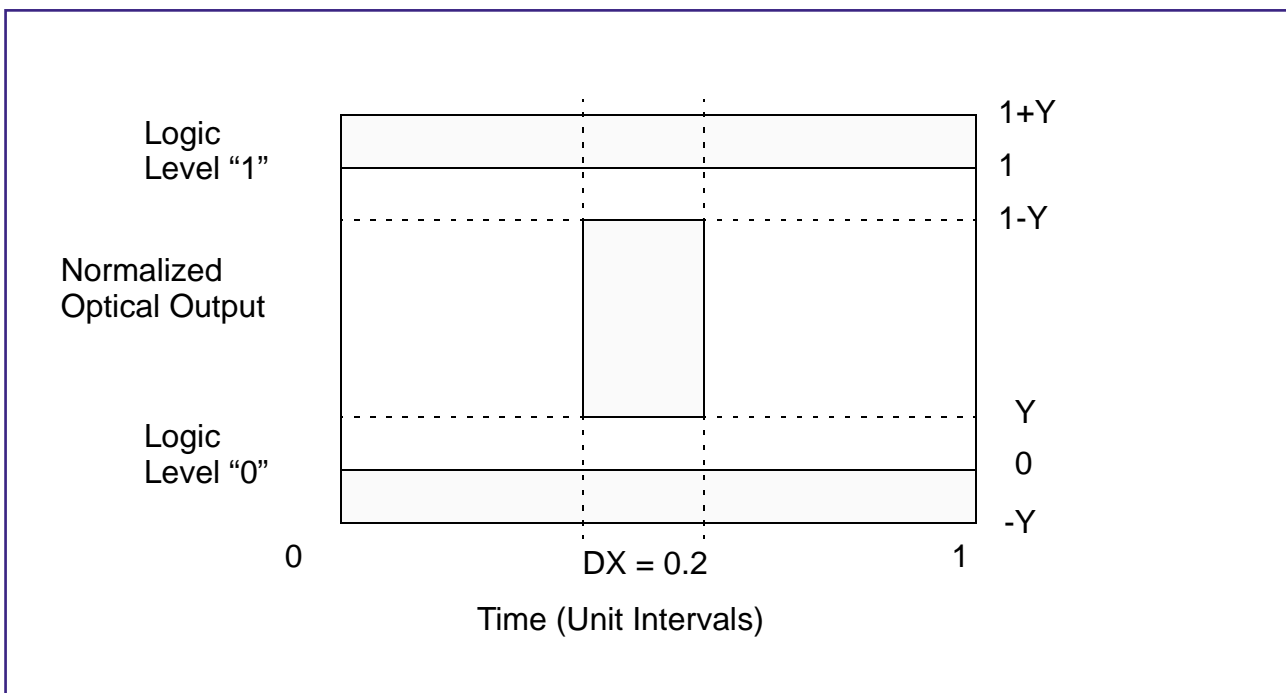

Figure 3: Optical eye/jitter characteristics

Wavelength

The tuneable module operates in groups of four wavelengths defined in table 6: System installation.

Table 6: Wavelength selection grid

No	Module	Reference	No	Module	Reference
1	MT25EW2722**_**	1527.22	24	MT25EW4532**_**	1545.32
2	MT25EW2799**_**	1527.99	25	MT25EW4612**_**	1546.12
3	MT25EW2877**_**	1528.77	26	MT25EW4692**_**	1546.92
4	MT25EW2955**_**	1529.55	27	MT25EW4772**_**	1547.72
5	MT25EW3033**_**	1530.33	28	MT25EW4851**_**	1548.51
6	MT25EW3112**_**	1531.12	29	MT25EW4932**_**	1549.32
7	MT25EW3190**_**	1531.90	30	MT25EW5012**_**	1550.12
8	MT25EW3268**_**	1532.68	31	MT25EW5092**_**	1550.92
9	MT25EW3347**_**	1533.47	32	MT25EW5172**_**	1551.72
10	MT25EW3425**_**	1534.25	33	MT25EW5252**_**	1552.52
11	MT25EW3504**_**	1535.04	34	MT25EW5333**_**	1553.33
12	MT25EW3582**_**	1535.82	35	MT25EW5413**_**	1554.13
13	MT25EW3661**_**	1536.61	36	MT25EW5494**_**	1554.94
14	MT25EW3740**_**	1537.40	37	MT25EW5575**_**	1555.75
15	MT25EW3819**_**	1538.19	38	MT25EW5655**_**	1556.55
16	MT25EW3898**_**	1538.98	39	MT25EW5736**_**	1557.36
17	MT25EW3977**_**	1539.77	40	MT25EW5817**_**	1558.17
18	MT25EW4056**_**	1540.56	41	MT25EW5898**_**	1558.98
19	MT25EW4135**_**	1541.35	42	MT25EW5979**_**	1559.79
20	MT25EW4214**_**	1542.14	43	MT25EW6061**_**	1560.61
21	MT25EW4294**_**	1542.94	44	MT25EW6142**_**	1561.42
22	MT25EW4373**_**	1543.73	45	MT25EW6223**_**	1562.23
23	MT25EW4453**_**	1544.53	46	MT25EW6305**_**	1563.05

Wavelength required is specified at the time of ordering.

For example:

MT25EW = Module, Transmitter, 2.488 Gb/s, Etalon, DWDM

MT25EW**2877**\$#-**. Wavelength required = 1528.77 nm

\$ Power C=3 mW (+1.7 dBm mean)

Reach C=160 km

** specify connector type and the fibre lengths

For SC(C28) connector, UPC polish and minimum connector return loss of -50 dB

Two Wire Interface

Communication with the module is via an industry standard synchronous two-wire interface.

Addressing

The module uses standard 7-bit addressing and has a fixed address of 60 h.

TWCK and TWDA

The two bus connections are implemented internally as an open collector interface. Pullups are not provided on board the module, these must be provided externally if the two wire bus is to be used. The value of the required pullups should be in the range 4.7 k to 10 k. The module supports two wire bus operation up to a maximum speed of 100 kHz. If the two wire bus is not used the TWCK and TWDA pins must be connected to either ground or Vcc, not left floating.

Clock Stretching

After being addressed and after every byte transfer from the host to the module, the module will hold the TWCK line low while the onboard processor readies data for either reception or transmission. The master device must be able to comply with this clock stretching technique. The time for which the clock is held low will typically be less than 0.1 ms.

Command Structure

All commands are one byte (eight bits) long. Extra data may be sent or received depending on the command. Some parameters are readable and writable (e.g. optical channel). In this case the same command is used to read or write, but the method of addressing the module determines if a read or a write operation occurs. See the table entitled "Two Wire Commands" for a complete list for the module command set.

Sending Data

To send a command to the module, first a start condition is asserted, followed by the address of the module, with the least significant bit (the R/W bit) clear. If the address matches that of the module, the module will acknowledge (ACK) on the next clock. The command is then sent to the module, which will also be acknowledged by the module. If no further data is to be sent, a stop condition can be asserted. If more data is to be sent, the module will ACK each byte until the stop condition is asserted. In the following diagrams, Slv ACK refers to the slave device (i.e. the module) acknowledging the master device. Mst ACK refers to the master device acknowledging the slave.

Sending command only

START	ADDRESS (R/W = 0)	Slv ACK	COMMAND	Slv ACK	STOP
-------	-------------------	---------	---------	---------	------

Sending command with extra data

START	ADDRESS (R/W = 0)	Slv ACK	COMMAND	Slv ACK	DATA1	Slv ACK	DATA2	Slv ACK	STOP
-------	-------------------	---------	---------	---------	-------	---------	-------	---------	------

Receiving Data

To receive data from the module e.g. submount temperature, first the module is addressed for write ($\overline{R/\overline{W}}$ bit clear) and the appropriate command is sent. After the module has returned an ACK, a re-start condition is asserted, and the module is re-addressed for read ($\overline{R/\overline{W}}$ bit set). The master can clock out the appropriate number of bytes from the module. The master must ACK the module for every byte received, apart from the last byte which the master must NACK. It is very important that the master sends NACK for the last byte, failure to do so can result in being unable to assert the stop condition if a low value has been set on the SDA line by the module.

Receiving one byte

START	ADDRESS ($\overline{R/\overline{W}} = 0$)	Slv ACK	COMMAND	Slv ACK	START	ADDRESS ($\overline{R/\overline{W}} = 1$)	Slv ACK	DATA	Mst NACK	STOP
-------	---	---------	---------	---------	-------	---	---------	------	----------	------

Receiving multiple bytes

START	ADDRESS ($\overline{R/\overline{W}} = 0$)	Slv ACK	COMMAND	Slv ACK	START	ADDRESS ($\overline{R/\overline{W}} = 1$)	Mst ACK	DATA	Mst ACK	DATA	Mst NACK	STOP
-------	---	---------	---------	---------	-------	---	---------	------	---------	------	----------	------

Command Set Details

CHN (00h)

Sets or return the current operating state. The command either accepts a one byte operand (unsigned) to set the output state or returns one byte on a read operation. Valid operands are:

- 00h - Module disabled
- 01h - Module enabled

DEF (01h)

Set or return the default power-on state of the module. The command either accepts a one byte operand (unsigned) to set the channel or returns one byte on a read operation. Valid channels are:

- 00h - Module disabled at power-on
- 01h - Module enabled as power-on

TUN (02h)

Set or return the optical wavelength fine tune value. This command accepts a one byte signed operand in the range -80 to +80 (two's complement). This will give an adjustment range of approximately 30 pm either side of the ITU grid wavelength. This value is volatile and is defaulted to zero on power up.

TWL (03h)

Return the ITU grid wavelength in pm. Result is returned as an unsigned 32-bit value, the MSB is returned first followed by the three lower bytes. The number returned is only a guide to the nominal wavelength of the currently selected channel and does not change if e.g. the TUN command is used to shift the frequency. Command is read-only.

LAS (04h)

Return the laser bias current in mA. Result is returned as an unsigned 16-bit value, MSB first followed by the LSB. Command is read-only.

SBT (05h)

Return the laser submount temperature in units of 1/10ths of a degree C, e.g. 345 = 34.5C. Result is returned as an unsigned 16-bit value, MSB first followed by the LSB. Command is read-only.

SBF (06h)

Return the current in uA of the short wavelength back-facet monitor (BFM). Result is returned as an unsigned 16-bit value, MSB first followed by the LSB. Command is read-only.

LBF (07h)

Return the current in uA of the long wavelength BFM. Result is returned as an unsigned 16-bit value, MSB first followed by the LSB. Command is read-only.

The sum of the short and long BFM currents can be used to monitor relative optical power.

The difference between the two gives an relative indication of wavelength.

STA (08h)
Return the module status. Module returns one byte that is divided into several bit fields as shown.

Command is read-only.

Status bits							
7	6	5	4	3	2	1	0
Etalon In Lock If set, all parameters are within tolerance	Temperature Alarm. If set, submount temperature is outside tolerance	Laser Alarm If set, optical power and/or ER are outside tolerance	Control loop state, see Control State table below for details				1

The following table describes the Control loop state bits

Status bit				Description
4	3	2	1	
0	0	0	0	THERMISTOR_STATE. Submount temperature is being stabilised under thermistor control
0	0	0	1	DUAL_BFM_ACQ_STATE. Submount temperature stabilised. Laser drive increased until a valid response is obtained from BFM's
0	0	1	0	DUAL_BFM_RAMP_STATE Submount temperature now under Etalon control. Optical power and extinction are ramping to their final values.
0	0	1	1	DUAL_BFM_LOCK_LASER Wavelength, optical power and extinction ratio have stabilised at their pre-set values. Module is ready for use.
0	1	0	0	DISABLE The processor has disabled the laser.
0	1	0	1	POWER_UP First state after power up. Laser is disabled while the microcontroller initialises peripherals.
0	1	1	0	EXTERNAL_LASER_DISABLE User has disabled the laser via the module disable input.
0	1	1	1	SYSTEM_CONFIG Module is initialising all calibration parameters after a power on.

SER (09h)

Return the module serial number. The serial number is 9 characters long and will typically include upper-case letters A-Z, digits 0-9, a period "." separator and may contain spaces to pad the serial number to nine characters if needed. All characters are returned in ASCII format. The serial number is sent in logical order i.e. first digit of the number is sent first. Command is read-only

THR (0Ah)

Returns the laser threshold calibration. Calibration value is returned as an unsigned 16-bit value, MSB first. This value is a factory set calibration value for internal control loop operation. The value is specific to each optical channel that the module supports and the value will not change under normal operation. Command is read-only.

MOD (0Bh)

Returns the laser modulation calibration. Calibration value is returned as an unsigned 16-bit value, MSB first. This value is a factory set calibration value for internal control loop operation. The value is specific to each optical channel that the module supports and the value will not change under normal operation. Command is read-only.

BIS (0Ch)

Returns the laser bias calibration. Calibration value is returned as an unsigned 16-bit value, MSB first. This value is a factory set calibration value for internal control loop operation. The value is specific to each optical channel that the module supports and the value will not change under normal operation. Command is read-only.

WAV (0Dh)

Returns the laser wavelength calibration. Calibration value is returned as an unsigned 16-bit value, MSB first. This value is a factory set calibration value for internal control loop operation. The value is specific to each optical channel that the module supports and the value will not change under normal operation. Command is read-only.

THM (10h)

Returns the submount temperature calibration. Calibration value is returned as an unsigned 16-bit value, MSB first. This value is a factory set calibration value for internal control loop operation. The value is specific to each optical channel that the module supports and the value will not change under normal operation. Command is read-only.

FWR (13h)

Returns the firmware revision. Result is returned as two unsigned bytes. The first value returned is the major revision number, the second is the minor revision. Command is read-only.

POW (16h)

Returns transmitted optical power in uW. The reported power will only be accurate whilst the module is wavelength locked (EIL flag active). During start-up and under certain fault conditions this monitor may not return an accurate representation of the transmitted power. Command is read-only.

Two Wire Command Summary

Command-Mnemonic	Command byte	Write Values	Read Values	Function
CHN	00h	(1 byte) 00h Disable 01h Enable	(1 byte) 00h Disabled 01h Enabled	Set or read laser disable state
DEF	01h	(1 byte) 00h Disabled 01h Enabled	(1 byte) 00h Disabled 01h Enabled	Set or read laser disable state at power up. 00h causes the module to power up in a laser disabled state.
TUN	02h	(1 signed byte) -80 to +80	(1 signed byte) -80 to +80	Fine tune the current wavelength
TWL	03h	-	(4 bytes) 32-bit value sent MSB first.	Returns the wavelength of the current channel in pm.
LAS	04h	-	(2 bytes) 16-bit value sent MSB first	Returns the laser bias current in mA.
SBT	05h	-	(2 bytes) 16-bit value sent MSB first	Returns the current submount temperature in C*10 (e.g. 125 would be 12.5 C)
SBF	06h	-	(2 bytes) 16-bit value sent MSB first	Returns the BFM current on the short wavelength side of the Etalon. Result is in uA.
LBF	07h	-	(2 bytes) 16-bit value sent MSB first	Returns the BFM current on the long wavelength side of the Etalon. Result is in uA.
STA	08h	-	(1 byte)	Return status byte.
SER	09h	-	(9 bytes)	Returns the serial number of the module.
THR	0Ah	-	(2 bytes) 16-bit value sent MSB first	Returns laser threshold calibration for the current channel
MOD	0Bh	-	(2 bytes) 16-bit value sent MSB first	Returns laser modulation calibration for the current channel
BIS	0Ch	-	(2 bytes) 16 bit value sent MSB first	Returns laser bias calibration for the current channel
WAV	0Dh	-	(2 bytes) 16-bit value sent MSB first	Returns laser wavelength calibration for the current channel
TYP	0Eh	-	(1 byte)	Returns laser type : 1= Single BFM 2= Dual BFM/Etalon
THM	10h	-	(2 bytes) 16-bit value sent MSB first	Return submount temperature calibration for the current channel
MCH	12h	-	(1 byte)	Returns the number of optical channels the module supports (1 to 4)
FWR	13h	-	(2 bytes)	Return firmware revision in the form Major/Minor e.g. first byte = 1, second byte = 2 would be revision 1.2)
POW	16h	-	(2 bytes) 16 bit value, MSB first	Returns transmitted optical power in uW

System installation

Electrostatic precautions

The module has built in protection and is qualified to ± 500 V, however the following procedures for handling ESD sensitive devices are recommended:

- reduce body charge by using non metallic carbon wrist stations
- ground the measuring and inspecting equipment and the work stations
- conduct assembly and testing at static protected work areas
- open shipment cartons in a static protected area
- make carrier jigs and packing cases conductive

Fibre handling

The secondary coated fibre pigtail has a nominal length of 1000 mm. Do not subject the fibre to excessive force and observe the minimum bend radius of 30 mm. The standard connector is an SC, C28 type. During soldering operations the fibre must be protected from excessive heat, maximum 85°C, and flux/cleaner contamination.

Soldering

It is recommended that the module is hand soldered. If wave soldering is used observe the maximum temperature and soldering times. In addition the case, which is not sealed, must not be immersed in or sprayed with any liquids.

General PCB layout guidelines

This module is a high speed electronic device. If the following advice is not adhered to, the module may fail to operate as required:

- follow high speed ECL design rules
- all high speed output lines must be controlled impedance lines with the termination impedance matching the line impedance. Ensure that paired lines such as DATA and $\overline{\text{DATA}}$ are of equal length. Avoid impedance interruptions such as 90° bends
- ensure that data and clock lines are as short and as straight as possible, and are isolated from noise sources and from each other
- ensure that the +5 V supply rail is decoupled and filtered
- use a multilayer PCB so that the ground plane surrounds the area underneath and around the receiver. Attach all ground pins directly to the ground plane with no additional lead length
- all unused outputs must be terminated. Recommended components are surface mount resistors and ceramic capacitors, X7R or equivalent

Recommended system interface

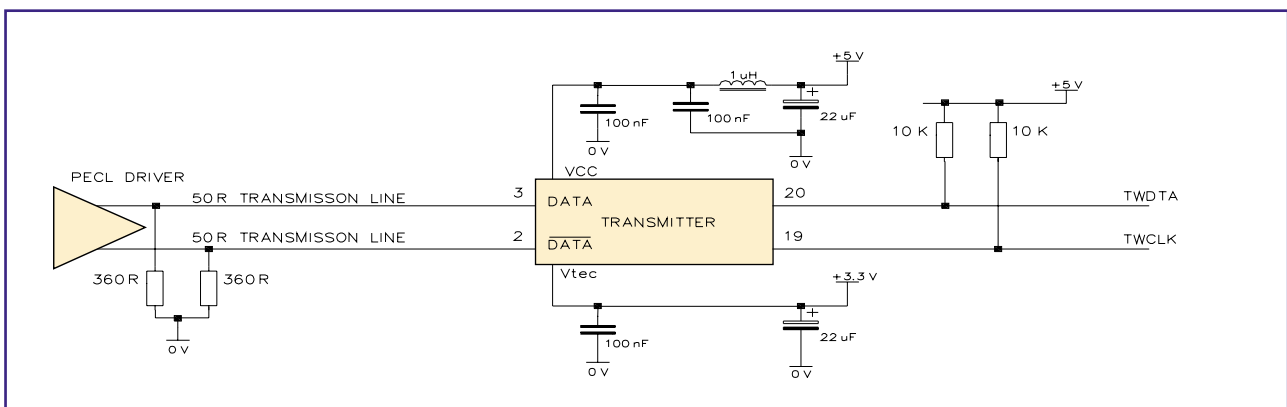

Ordering Information

For information on ordering this product please refer to table 6 on page 8 of this document.



Thinking optical solutions

North America

Bookham Technology Inc.
49 Buford Highway
Suwanee
GA 30024
USA

- Tel: +1 678 482 4021
- Fax: +1 678 482 4022

Europe

Bookham Technology plc
Brixham Road
Paignton
Devon
TQ4 7BE
UK

- Tel: +44 (0) 1803 66 2875
- Fax: +44 (0) 1803 66 2801

Asia

Bookham Technology plc
21/F Cityplaza One
1111 King's Road
Quarry Bay
Hong Kong

- Tel: +852 (2100) 2249
- Fax: +852 (2100) 2585

Sales@bookham.com

Important Notice

Bookham Technology has a policy of continuous improvement, as a result certain parameters detailed on this flyer may be subject to change without notice. If you are interested in a particular product please request the available from any Bookham Technology sales representative.



REFERENCE IEC 60825-1: Edition 1.2



This product complies with 21CFR 1040.10 and has been assessed as Class I for non-viewed sources

