

## 980nm Terrestrial and Submarine Pump Laser Diode Series

### G07

**The Bookham Technology G07 980nm Terrestrial and Submarine Pump Laser Diode Series have been designed and optimized for use as high-power, highly reliable pump sources for the latest erbium-doped fiber and waveguide amplifiers. The G07 is ideally suited for very low noise wavelength-locked operation with an FBG.**

#### Features

- Kink-free operations from 480 to 700mW
- High slope efficiency of 0.93W/A
- Rollover power in excess of 1.3W
- Small vertical farfield of 21 deg
- Failure rate below 500 FIT for an operating power up to 600mW
- Shippable as chip or burnt-in chip on a submount

#### Applications

- Pump modules for EDFAs, EDWAs, and other single mode high power laser diode applications



## Characteristics

Parameter	Conditions	Min	Typ	Max	Unit
Kinkfree Output Power		480	600		mW
Threshold Current			37	48	mA
Operating Current	@250mW		320	340	mA
Operating Voltage	@250mW		1.45	1.7	V
Centre Wavelength 1)	@250mW	970		990	nm
Spectral Width 2)	@250mW	0.2	5	7	nm
Lateral FWHM	@250mW	5.8	7	8.5	deg
Vertical FWHM	@250mW	19	21	23.5	deg
Slope Efficiency			0.93		mW/mA
Spectral Shift with Temperature	measured on submount		0.3		nm/K
Spectral Shift with Current	measured on submount		0.013		nm/mA

1) Wavelength selectable, extended range on request (920 - 1060nm)

2) 95% of the total spectral power

## Absolute Maximum Ratings

Parameter	Comments	Min	Max	Unit
Storage Temperature	in Gelpack	-40	85	°C
		-40	50	°C
Operating Temperature 1)		-40	80	°C
Forward Current	max. 10 sec @ 25°C max. 10 sec @ 70°C		1200	mA
			1300	mA
Reverse Voltage			2	V
Processing Temperature:	chip: max. 30 sec chip-on-submount: max. 10 sec		320	°C
			250	°C
ESD	Human Body Model, Class 5		4	kV

1) Device reliability is a function of operating temperature & current.

## Module performance of G07 chip with FBG stabilization

The G07 laser shows an excellent Bragg grating stabilization performance. Low frequency power variations of less than 0.05dB (>40mW) and a -20dB optical bandwidth below 1.5nm are possible with properly stabilized devices. An application note for FBG stabilization is available.

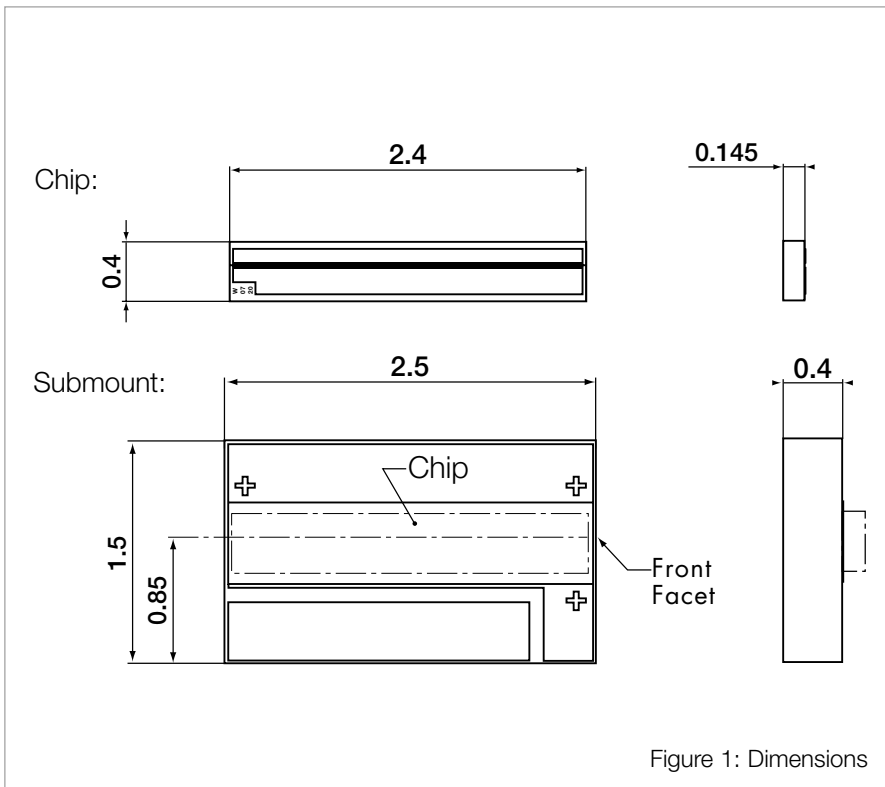

Figure 1: Dimensions

**Ordering Information**

Please contact your Bookham Technology plc representative quoting the relevant ordering information below:

Product Code	Product Name
G07	980nm Terrestrial and Submarine Pump Laser Diode Series
G07 CoS	980nm Terrestrial and Submarine Pump Laser Diode Series on Submount

**North America**

Bookham Technology Inc.  
49 Buford Highway  
Suwanee  
GA 30024  
USA

- Tel: +1 678 482 4021
- Fax: +1 678 482 4022

**Europe**

Bookham Technology plc  
Brixham Road  
Paignton  
Devon  
TQ4 7BE  
UK

- Tel: +44 (0) 1803 66 2875
- Fax: +44 (0) 1803 66 2801

**Asia**

Bookham Technology plc  
Hong Kong Representative Office  
Rm 2207-9  
Tower 2  
Lippo Centre  
Admiralty, Central  
Hong Kong

- Tel: +852 2530 8822
- Fax: +852 2530 8102

[sales@bookham.com](mailto:sales@bookham.com)

**Important Notice**

Performance figures, data and any illustrative material provided in this data sheet are typical and must be specifically confirmed in writing by Bookham Technology before they become applicable to any particular order or contract. In accordance with Bookham Technology's policy of continuous improvement specifications may change without notice. The publication of information in this data sheet does not imply freedom from patent or other protective rights of Bookham Technology or others. Further details are available from any Bookham Technology sales representative.



REFERENCE IEC 60825-1 : Edition 1.2



THIS PRODUCT COMPLIES WITH 21 CFR 1040.10



**Site Approvals:**



ISO9001:2000  
FM68159