

**QUAD OP AMP AND VOLTAGE REFERENCE****AP4302****General Description**

The AP4302 is a monolithic IC specifically designed to regulate the output current and voltage levels of switching battery chargers and power supplies.

The device contains quad Op Amps and a 2.5V externally adjusted voltage reference in a 16-pin package. The four Op Amps feature accurate voltage and current control. Combining a stable voltage reference with the four Op Amps makes AP4302 ideal for use in multi-function charger, power supply voltage monitor, signal processing and control system.

The IC offers the power converter designer a control solution that features increased precision with a corresponding reduction in system complexity and cost.

The AP4302 is available in standard packages of DIP-16 and SOIC-16.

Features**Op Amp**

- Input Offset Voltage: 0.5mV
- Supply Current: 250 μ A per Op Amp at 5.0V Supply Voltage
- Unity Gain Bandwidth: 1MHz
- Output Voltage Swing: 0 to ($V_{CC} - 1.5$)V
- Power Supply Range: 3 to 18V

Voltage Reference

- Reference Voltage Tolerance: 0.5%, 1%
- Sink Current Capability from 0.1 to 80mA
- Output Dynamic Impedance: 0.2 Ω
- Externally Adjusted Voltage Reference: 2.5V

Applications

- Battery Charger
- Switching Power Supply

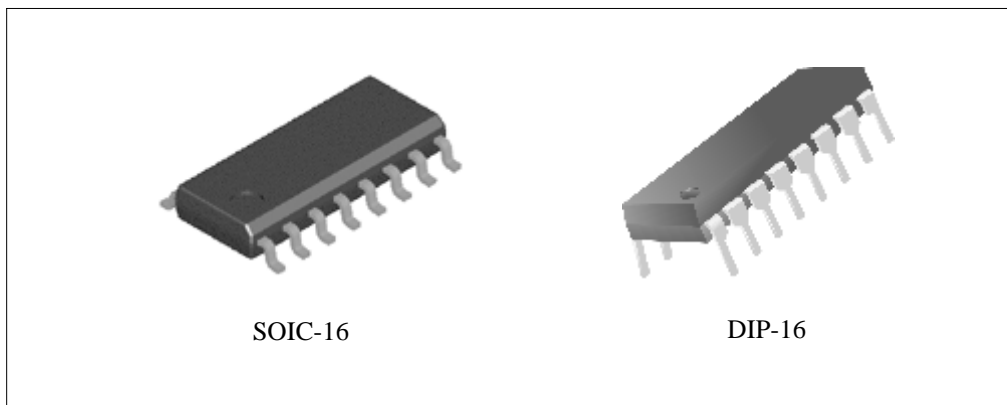

Figure 1. Package Types of AP4302



QUAD OP AMP AND VOLTAGE REFERENCE

AP4302

Pin Configuration

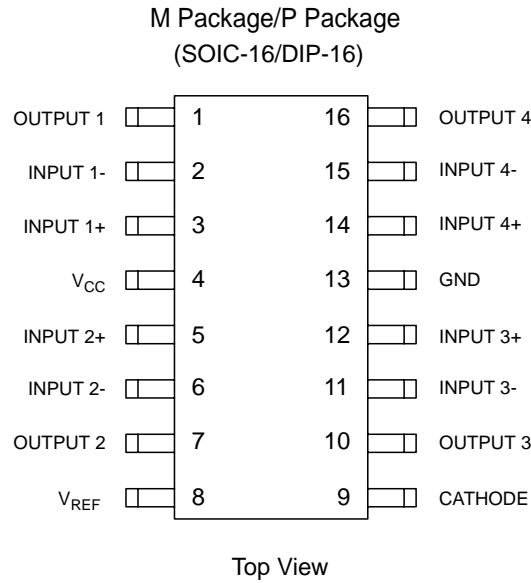

Figure 2. Pin configuration of AP4302

Functional Block Diagram

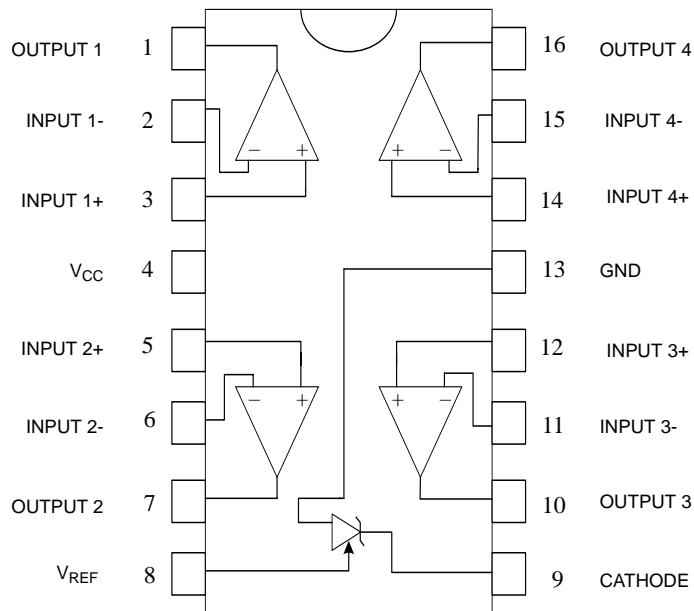

Figure 3. Functional Block Diagram of AP4302



QUAD OP AMP AND VOLTAGE REFERENCE

AP4302

Functional Block Diagram (Continued)

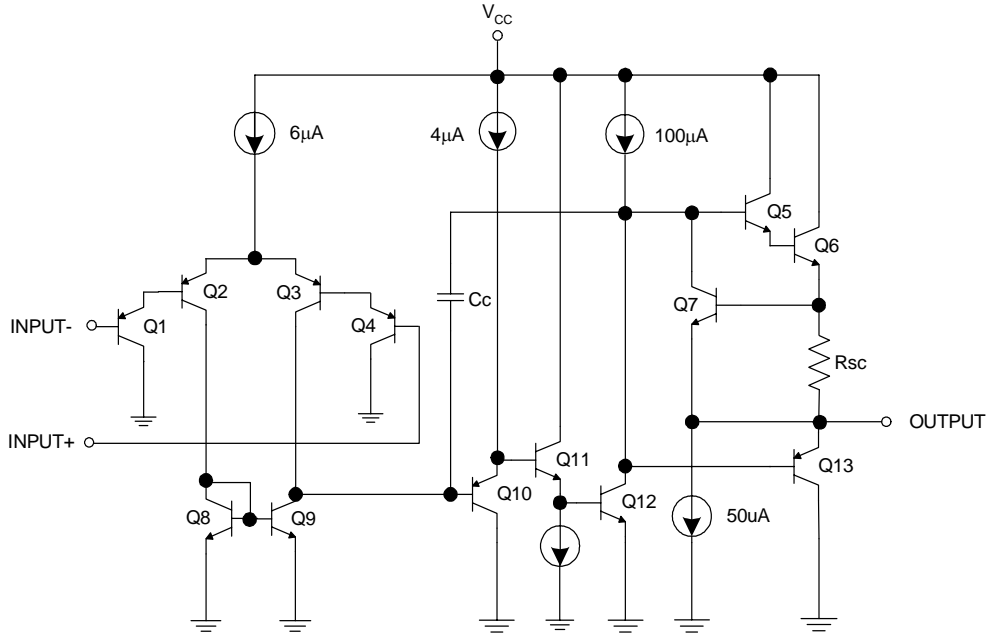

Figure 4. Op Amp Functional Block Diagram (Each Amplifier)

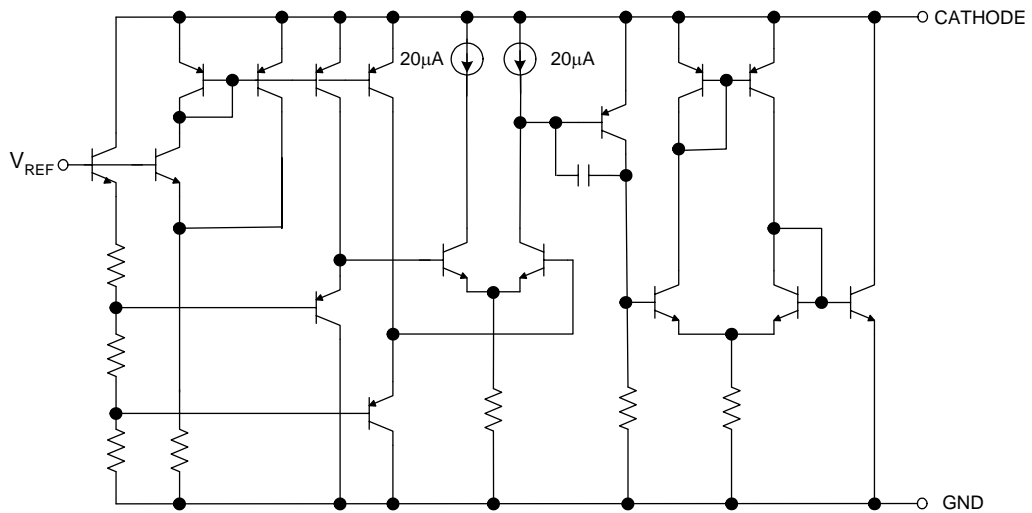
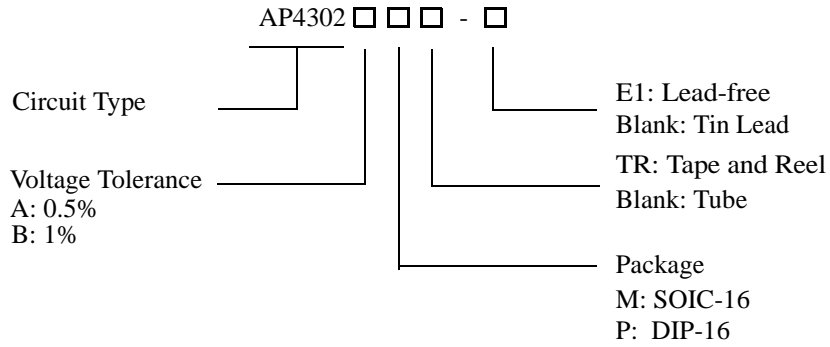

Figure 5. Voltage Reference Functional Block Diagram



QUAD OP AMP AND VOLTAGE REFERENCE **AP4302**

Ordering Information



Package	Voltage Tol-erance	Tempera-ture Range	Part Number		Marking ID		Packing Type
			Tin Lead	Lead Free	Tin Lead	Lead Free	
DIP-16	0.5%	-40 to 85°C	AP4302AP	AP4302AP-E1	AP4302AP	AP4302AP-E1	Tube
	1%		AP4302BP	AP4302BP-E1	AP4302BP	AP4302BP-E1	
SOIC-16	0.5%	-40 to 85°C	AP4302AM	AP4302AM-E1	AP4302AM	AP4302AM-E1	Tube
			AP4302AMTR	AP4302AMTR-E1	AP4302AM	AP4302AM-E1	Tape & Reel
	1%		AP4302BM	AP4302BM-E1	AP4302BM	AP4302BM-E1	Tube
			AP4302BMTR	AP4302BMTR-E1	AP4302BM	AP4302BM-E1	Tape & Reel

BCD Semiconductor's Pb-free products, as designated with "E1" suffix in the part number, are RoHS compliant.

**QUAD OP AMP AND VOLTAGE REFERENCE****AP4302****Absolute Maximum Ratings (Note 1)**

Parameter	Symbol	Value	Unit
Power Supply Voltage (V_{CC} to GND)	V_{CC}	20	V
Input Voltage Range	V_{IN}	-0.3 to $V_{CC} + 0.3$	V
Op Amp Input Differential Voltage	V_{ID}	20	V
Voltage Reference Cathode Current	I_K	100	mA
Power Dissipation	DIP-16	P_D	mW
	SOIC-16		
Storage Temperature Range	T_{STG}	-65 to 150	°C
ESD Protection Voltage (Machine Model)		>200	V

Note 1: Stresses greater than those listed under "Absolute Maximum Ratings" may cause permanent damage to the device. These are stress ratings only, and functional operation of the device at these or any other conditions beyond those indicated under "Recommended Operating Conditions" is not implied. Exposure to "Absolute Maximum Ratings" for extended periods may affect device reliability.

Recommended Operating Conditions

Parameter	Min	Max	Unit
Supply Voltage	3	18	V
Ambient Temperature	-40	85	°C



QUAD OP AMP AND VOLTAGE REFERENCE

AP4302

Electrical Characteristics

Operating Conditions: $V_{CC} = +5V$, $T_A = 25^\circ C$ unless otherwise specified.

Parameter	Conditions	Min	Typ	Max	Unit	
Total Supply Current, Excluding Current in Voltage Reference	$V_{CC} = 5V$, no load, $-40^\circ C \leq T_A \leq 85^\circ C$		1.0	1.6	mA	
	$V_{CC} = 18V$, no load, $-40^\circ C \leq T_A \leq 85^\circ C$		1.2	2.4		
Voltage Reference Section						
Reference Voltage	$I_{KA} = 10mA$ $T_A = 25^\circ C$	0.5% tolerance	2.487	2.500	2.513	V
		1% tolerance	2.475			
Reference Voltage Deviation over Full Temperature Range	$I_{KA} = 10mA$, $T_A = -40$ to $85^\circ C$			5	24	mV
Minimum Cathode Current for Regulation				0.1	0.2	mA
Ratio of Change in V_{REF} to that of Cathode Voltage	$I_{KA} = 10mA$	V_{REF} to 10V		1.0	2.7	mV/V
		10V to 18V		0.5	2.0	
Reference Current	$I_{KA} = 10mA$, $R1 = 10K$, $R2 = \infty$			0.7	4	μA
The Deviation of Reference Current over Temperature	$V_{KA} = V_{REF}$, $I_{KA} = 10mA$, $T_A = -40$ to $85^\circ C$			0.4	1.2	μA
Off-State Cathode Current	$V_{REF} = 0$, $V_{KA} = 18V$			0.05	1.0	μA
Dynamic Impedance	$I_{KA} = 1.0$ to $80mA$, $f < 1kHz$			0.2	0.5	Ω



QUAD OP AMP AND VOLTAGE REFERENCE

AP4302

Electrical Characteristics (Continued)

Operating Conditions: $V_{CC} = +5V$, $T_A = 25^\circ C$ unless otherwise specified.

Parameter	Conditions	Min	Typ	Max	Unit
Op Amp Section (per Op Amp) ($V_{CC} = 5V$, $V_O = 1.4V$, $T_A = 25^\circ C$, unless otherwise noted)					
Input Offset Voltage	$T_A = 25^\circ C$		0.5	3	mV
	$T_A = -40$ to $85^\circ C$			5	
Input Offset Voltage Temperature Drift	$T_A = -40$ to $85^\circ C$		7		$\mu V/^\circ C$
Input Offset Current	$T_A = 25^\circ C$		2	30	nA
Input Bias Current	$T_A = 25^\circ C$		20	150	nA
Input Voltage Range	$V_{CC} = 0$ to $18V$	0		$V_{CC} - 1.5$	V
Common Mode Rejection Ratio	$T_A = 25^\circ C$, $V_{CM} = 0$ to $3.5V$	70	85		dB
Large Signal Voltage Gain	$V_{CC} = 15V$, $R_L = 2k\Omega$, $V_O = 1.4$ to $11.4V$	85	100		dB
Power Supply Rejection Ratio	$V_{CC} = 5$ to $18V$	70	90		dB
Output Current	Source	$V_{CC} = 15V$, $V_{ID} = 1V$, $V_O = 2V$	20	40	mA
	Sink	$V_{CC} = 15V$, $V_{ID} = -1V$, $V_O = 2V$	10	20	mA
Output Voltage Swing (High)	$V_{CC} = 18$, $R_L = 10k\Omega$, $V_{ID} = 1V$	16	16.5		V
Output Voltage Swing (Low)	$V_{CC} = 18$, $R_L = 10k\Omega$, $V_{ID} = -1V$		17	100	mV
Slew Rate	$V_{CC} = 18V$, $R_L = 2k\Omega$, $A_V = 1$, $V_{IN} = 0.5$ to $2V$, $C_L = 100pF$	0.3	0.5		$V/\mu s$
Gain Bandwidth Product	$V_{CC} = 18V$, $R_L = 2k\Omega$, $C_L = 100pF$, $V_{IN} = 10mV$, $f=100kHz$	0.7	1		MHz



QUAD OP AMP AND VOLTAGE REFERENCE

AP4302

Typical Performance Characteristics

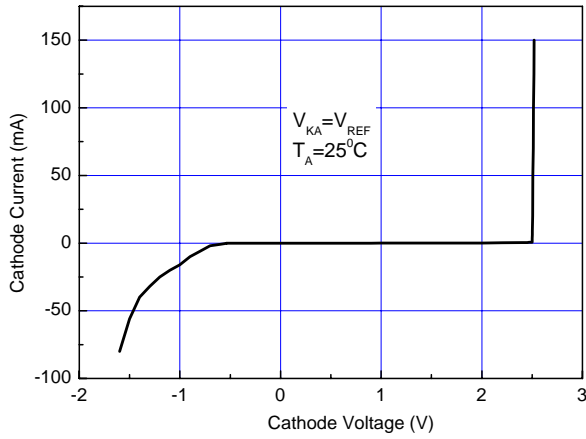

Figure 6. Cathode Current vs. Cathode Voltage

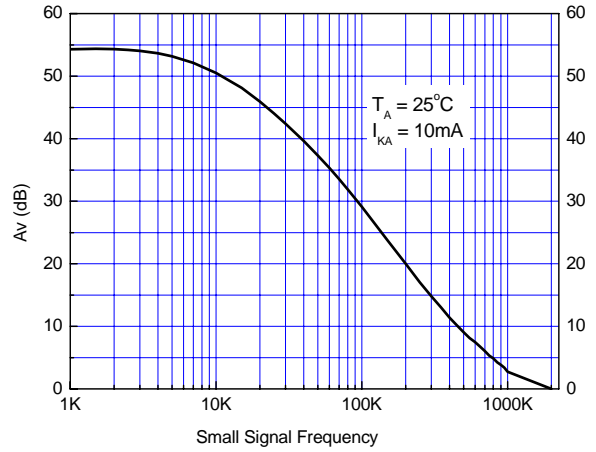

Figure 7. Voltage Reference Small Signal Voltage Gain vs. Frequency

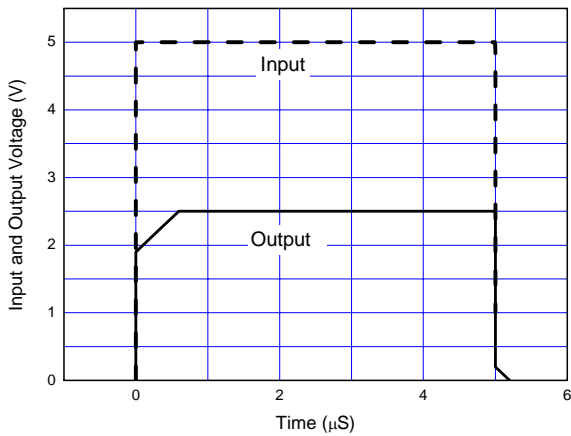

Figure 8. Pulse Response of Input and Output Voltage

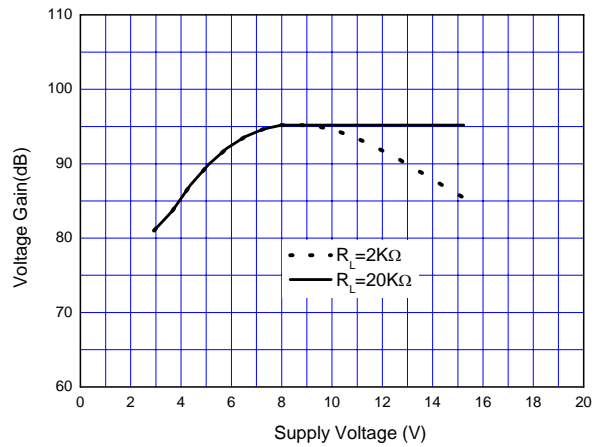

Figure 9. Op Amp Voltage Gain



QUAD OP AMP AND VOLTAGE REFERENCE

AP4302

Typical Performance Characteristics (Continued)

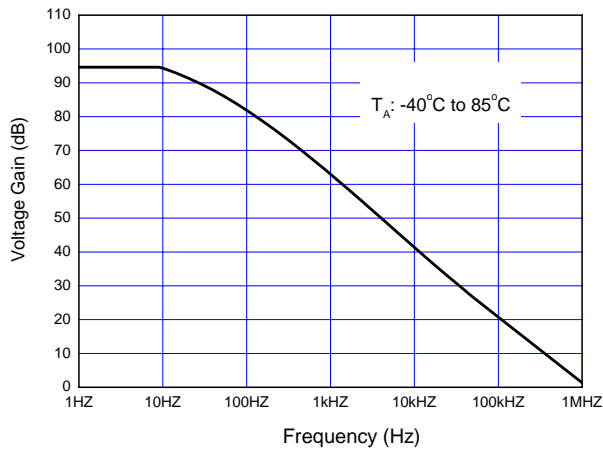

Figure 10. Op Amp Open Loop Frequency Response

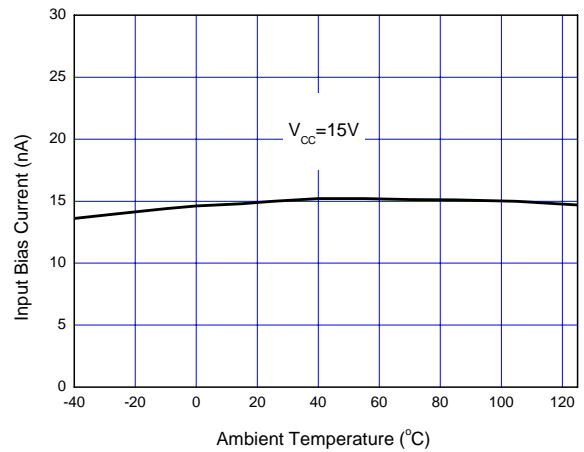

Figure 11. Op Amp Input Current



QUAD OP AMP AND VOLTAGE REFERENCE

AP4302

Mechanical Dimensions

DIP-16

Unit: mm(inch)

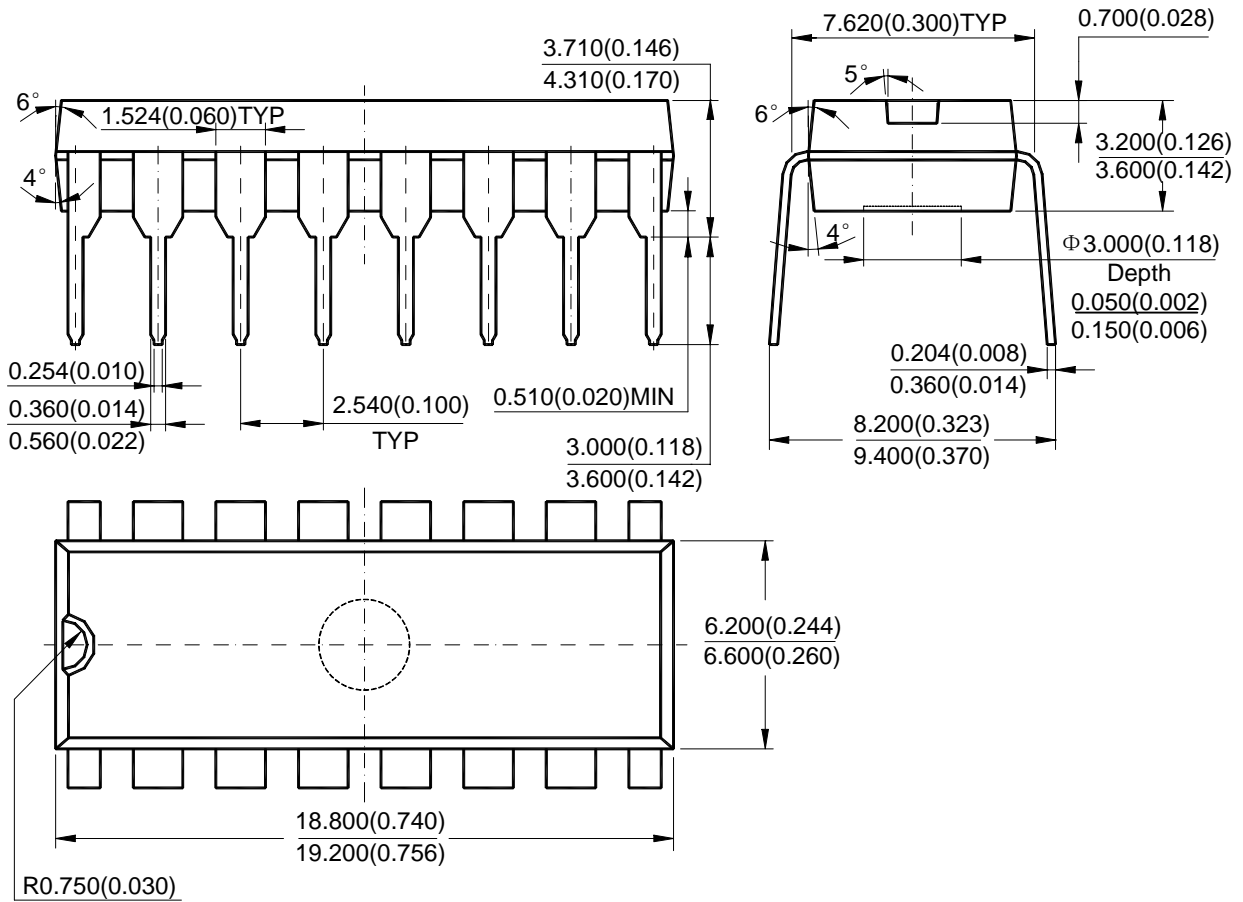



QUAD OP AMP AND VOLTAGE REFERENCE

AP4302

Mechanical Dimensions (Continued)

SOIC-16

Unit: mm(inch)

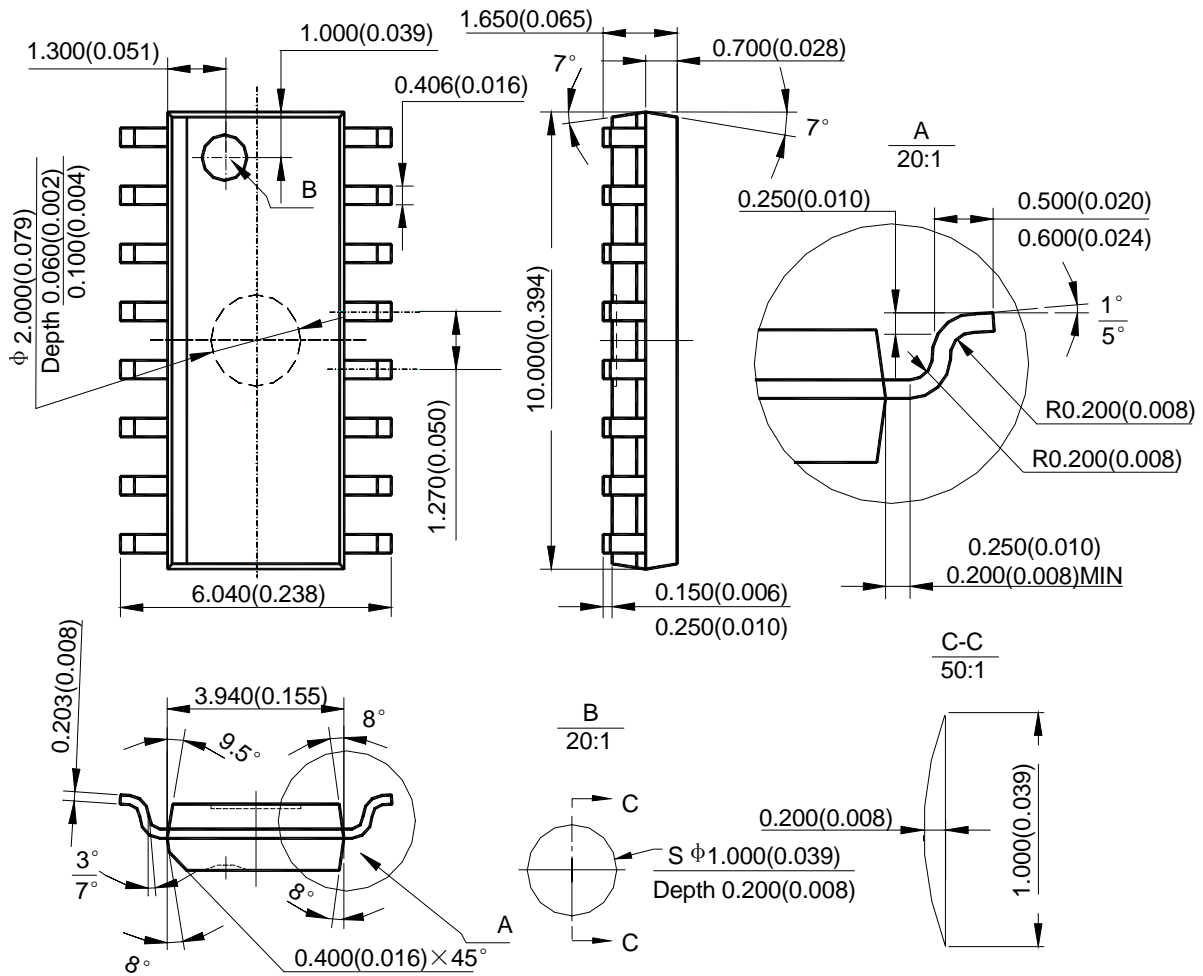



BCD Semiconductor Manufacturing Limited

<http://www.bcdsemi.com>

BCD Semiconductor Corporation

3170 De La Cruz Blvd, Suite # 105 Santa Clara, CA 95054-2411, U.S.A

Tel: +1-408-988 6388, Fax: +1-408-988 6386

Shanghai SIM-BCD Semiconductor Manufacturing Co., Ltd.

800 Yi Shan Road, Shanghai 200233, PRC

Tel: +86-21-6485-1491, Fax: +86-21-5450-0008

Advanced Analog Circuits (Shanghai) Corporation

8F, B Zone, 900 Yi Shan Road, Shanghai 200233, PRC

Tel: +86-21-6495 9539, Fax: +86-21-6485 9673

BCD Semiconductor (Taiwan) Company Limited

Room 2210, 22nd Fl, 333, Keelung Road, Sec. 1, TaiPei (110), Taiwan

Tel: +886-2-2758 6828, Fax: +886-2-2758 6892

IMPORTANT NOTICE

BCD Semiconductor Manufacturing Limited reserves the right to make changes without further notice to any products or specifications herein. BCD Semiconductor Manufacturing Limited does not assume any responsibility for use of any its products for any particular purpose, nor does BCD Semiconductor Manufacturing Limited assume any liability arising out of the application or use of any its products or circuits. BCD Semiconductor Manufacturing Limited does not convey any license under its patent rights or other rights nor the rights of others.