

Phase-Control IC – Tacho Applications/Overload Limitation

Description

The integrated circuit U211B is designed as a phase-control circuit in bipolar technology with an internal frequency-voltage converter. Furthermore, it has an internal control amplifier which means it can be used for

speed-regulated motor applications.

It has an integrated load limitation, tacho monitoring and soft-start functions, etc. to realize sophisticated motor control systems.

Features

- Internal frequency-to-voltage converter
- Externally-controlled integrated amplifier
- Overload limitation with a “fold back” characteristic
- Optimized soft-start function
- Tacho monitoring for shorted and open loop
- Automatic retriggering switchable
- Triggering pulse typ. 155 mA
- Voltage and current synchronization
- Internal supply-voltage monitoring
- Temperature reference source
- Current requirement ≤ 3 mA

Block Diagram

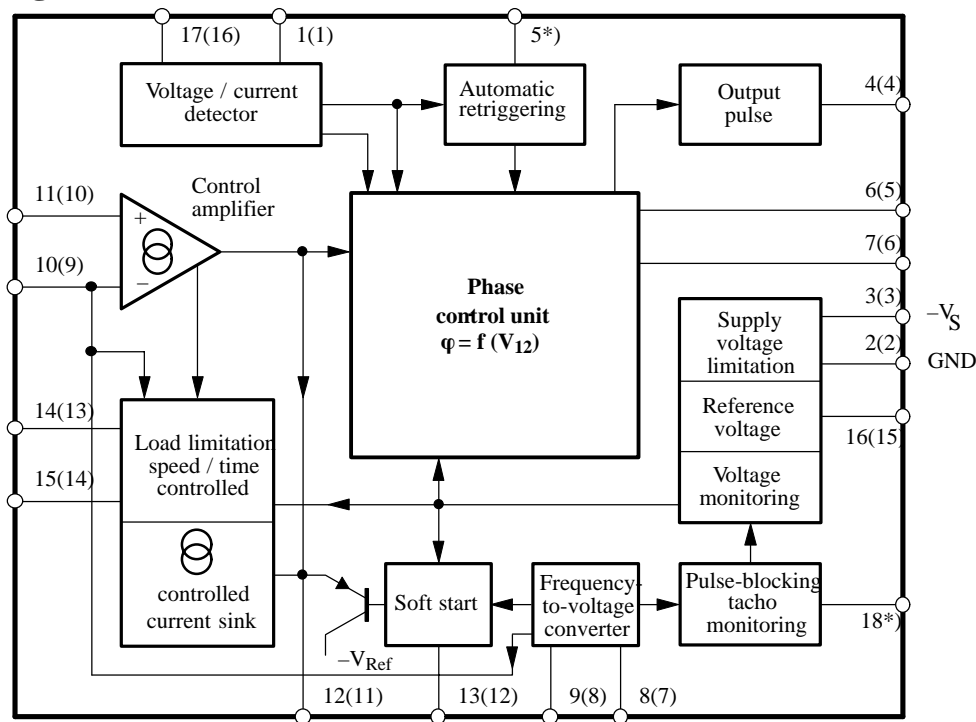

Figure 1. Block diagram (Pins in brackets refer to SO16)
 *) Pins 5 and 18 connected internally

Order Information

Extended Type Number	Package	Remarks
U211B-x	DIP18	Tube
U211B-xFP	SO16	Tube
U211B-xFPG3	SO16	Taped and reeled

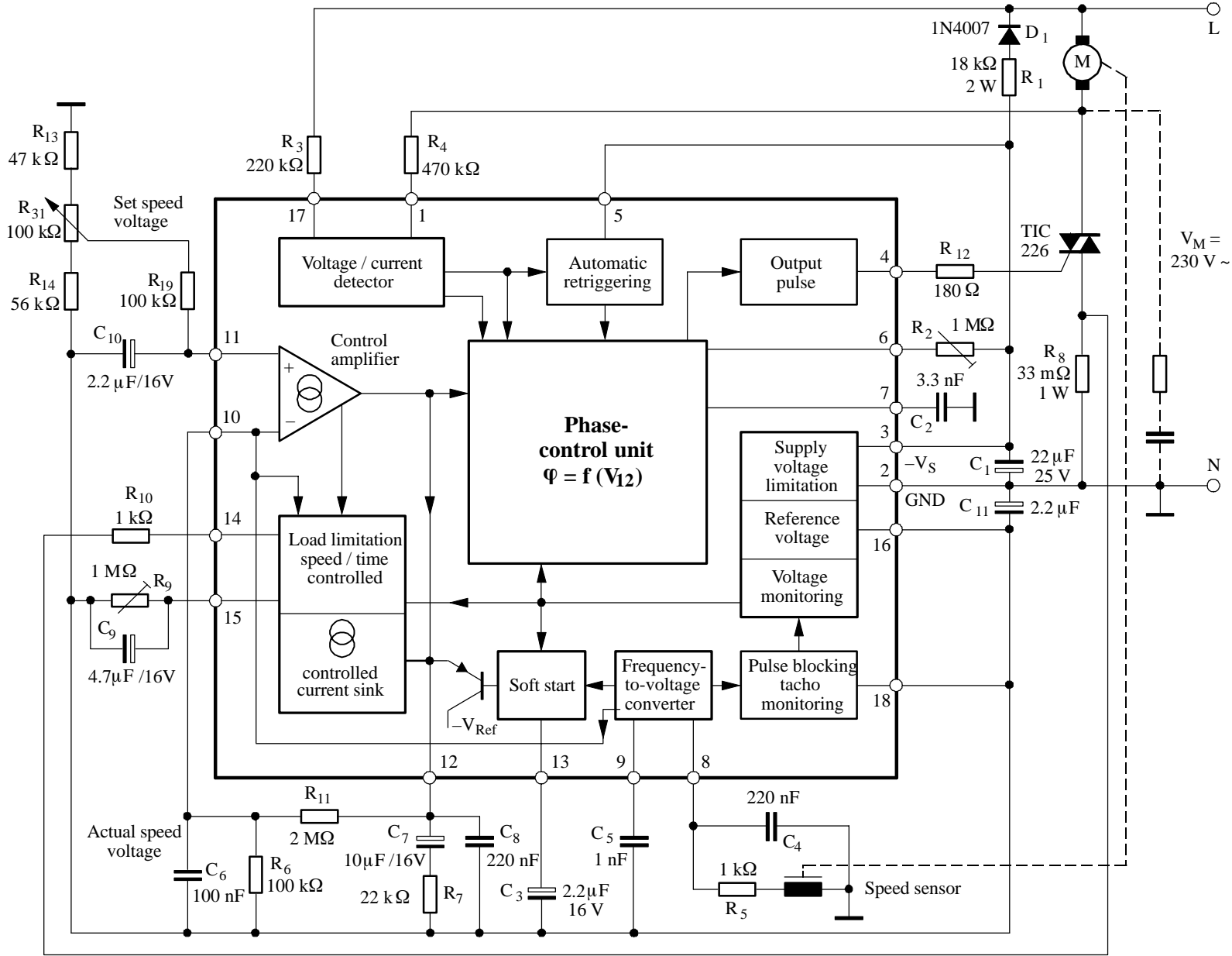

Figure 2. Speed control, automatic retriggering, load limiting, soft start

Pin Description

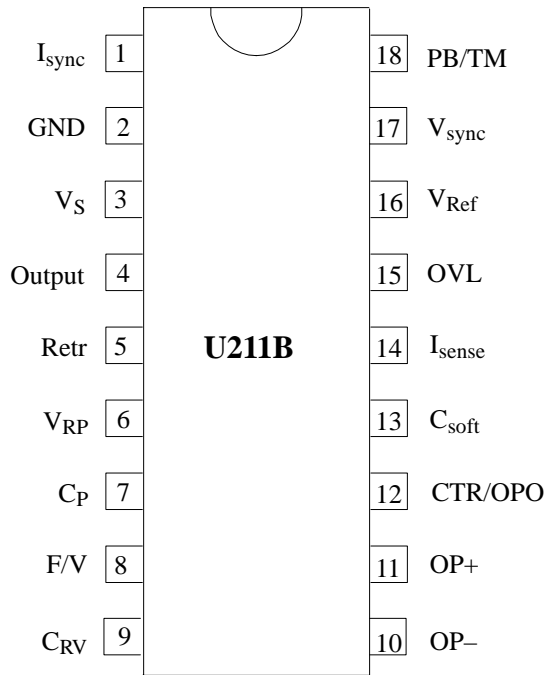

Figure 3. Pinning DIP18

Pin	Symbol	Function
1	I_{sync}	Current synchronization
2	GND	Ground
3	V_S	Supply voltage
4	Output	Trigger pulse output
5	Retr	Retrigger programming
6	V_{RP}	Ramp current adjust
7	C_P	Ramp voltage
8	F/V	Frequency-voltage converter
9	C_{RV}	Charge pump
10	OP-	OP inverting input
11	OP+	OP non-inverting input
12	CTR/OPO	Control input / OP output
13	C_{soft}	Soft start
14	I_{sense}	Load-current sensing
15	OVL	Overload adjust
16	V_{ref}	Reference voltage
17	V_{sync}	Voltage synchronization
18	PB/TM	Pulse blocking / tacho monitoring

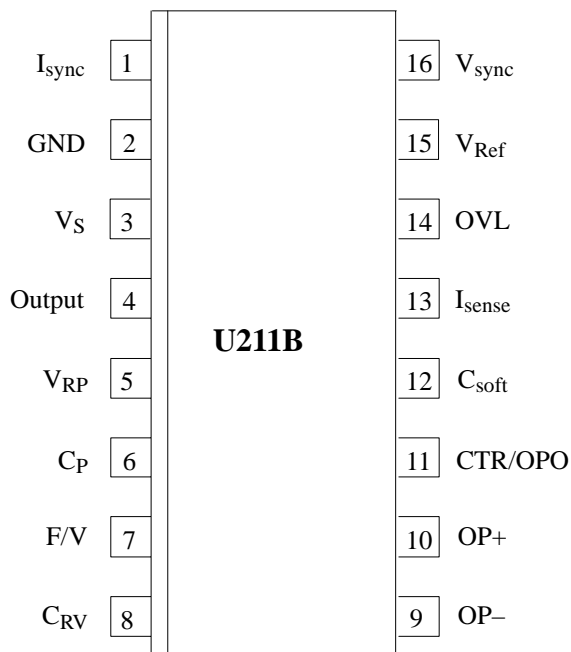

Figure 4. Pinning SO16

Pin	Symbol	Function
1	I_{sync}	Current synchronization
2	GND	Ground
3	V_S	Supply voltage
4	Output	Trigger pulse output
5	V_{RP}	Ramp current adjust
6	C_P	Ramp voltage
7	F/V	Frequency-voltage converter
8	C_{RV}	Charge pump
9	OP-	OP inverting input
10	OP+	OP non-inverting input
11	CTR/OPO	Control input / OP output
12	C_{soft}	Soft start
13	I_{sense}	Load-current sensing
14	OVL	Overload adjust
15	V_{ref}	Reference voltage
16	V_{sync}	Voltage synchronization

Description

Mains Supply

The U211B is fitted with voltage limiting and can therefore be supplied directly from the mains. The supply voltage between Pin 2 (+ pol/⊥) and Pin 3 builds up across D_1 and R_1 and is smoothed by C_1 . The value of the series resistance can be approximated using:

$$R_1 = \frac{V_M - V_S}{2 I_S}$$

Further information regarding the design of the mains supply can be found in the design hints. The reference voltage source on Pin 16 of typ. -8.9 V is derived from the supply voltage and is used for regulation.

Operation using an externally stabilized DC voltage is not recommended.

If the supply cannot be taken directly from the mains because the power dissipation in R_1 would be too large, then the circuit shown in figure 5 should be used.

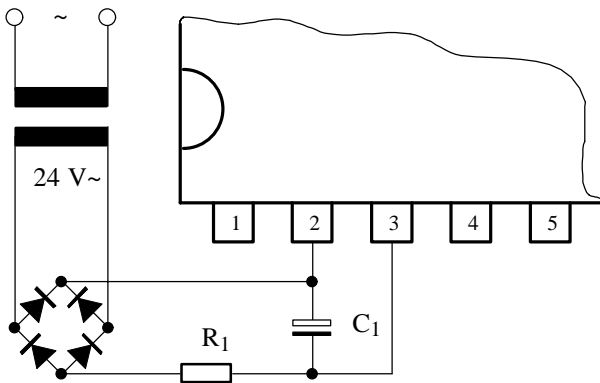

Figure 5. Supply voltage for high current requirements

Phase Control

The phase angle of the trigger pulse is derived by comparing the ramp voltage (which is mains synchronized by the voltage detector) with the set value on the control input Pin 12. The slope of the ramp is determined by C_2 and its charging current. The charging current can be varied using R_2 on Pin 6. The maximum phase angle α_{\max} can also be adjusted using R_2 .

When the potential on Pin 7 reaches the nominal value predetermined at Pin 12, then a trigger pulse is generated whose width t_p is determined by the value of C_2 (the value of C_2 and hence the pulse width can be evaluated by assuming $8\ \mu\text{s/nF}$). At the same time, a latch is set, so that as long as the automatic retriggering has not been activated, no more pulses can be generated in that half cycle.

The current sensor on Pin 1 ensures that, for operations with inductive loads, no pulse will be generated in a new half cycle as long as a current from the previous half cycle is still flowing in the opposite direction to the supply voltage at that instant. This makes sure that “gaps” in the load current are prevented.

The control signal on Pin 12 can be in the range 0 V to -7 V (reference point Pin 2).

If $V_{12} = -7\text{ V}$, the phase angle is at maximum = α_{\max} , i.e., the current flow angle is a minimum. The phase angle α_{\min} is minimum when $V_{12} = V_2$.

Voltage Monitoring

As the voltage is built up, uncontrolled output pulses are avoided by internal voltage surveillance. At the same time, all latches in the circuit (phase control, load limit regulation, soft start) are reset and the soft-start capacitor is short circuited. Used with a switching hysteresis of 300 mV , this system guarantees defined start-up behavior each time the supply voltage is switched on or after short interruptions of the mains supply.

Soft Start

As soon as the supply voltage builds up (t_1), the integrated soft start is initiated. Figure 6 shows the behaviour of the voltage across the soft-start capacitor which is identical with the voltage on the phase-control input on Pin 12. This behavior guarantees a gentle start-up for the motor and automatically ensures the optimum run-up time.

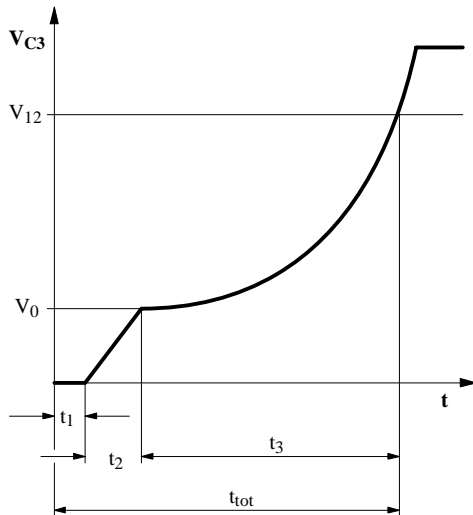

Figure 6. Soft start

- t_1 = build-up of supply voltage
- t_2 = charging of C_3 to starting voltage
- $t_1 + t_2$ = dead time
- t_3 = run-up time
- t_{tot} = total start-up time to required speed

C_3 is first charged up to the starting voltage V_0 with a current of typically $45 \mu\text{A}$ (t_2). By then reducing the charging current to approx. $4 \mu\text{A}$, the slope of the charging function is substantially reduced so that the rotational speed of the motor only slowly increases. The charging current then increases as the voltage across C_3 increases, resulting in a progressively rising charging function which accelerates the motor more and more with increasing rotational speed. The charging function determines the acceleration up to the set-point. The charging current can have a maximum value of $55 \mu\text{A}$.

Frequency-to-Voltage Converter

The internal frequency-to-voltage converter (f/V-converter) generates a DC signal on Pin 10 which is proportional to the rotational speed using an AC signal from a tachometer or a light beam whose frequency is in turn dependent on the rotational speed. The high-impedance input Pin 8 compares the tachometer voltage to a switch-on threshold of typ. -100 mV . The switch-off threshold is given with -50 mV . The hysteresis guarantees very reliable operation even when relatively simple tachometer generators are used. The tachometer frequency is given by:

$$f = \frac{n}{60} \times p \text{ (Hz)}$$

- where: n = revolutions per minute
- p = number of pulses per revolution

The converter is based on the charge pumping principle. With each negative half wave of the input signal, a quantity of charge determined by C_5 is internally amplified and then integrated by C_6 at the converter output on Pin 10. The conversion constant is determined by C_5 , its charge transfer voltage of V_{ch} , R_6 (Pin 10) and the internally adjusted charge transfer gain.

$$G_i \left[\frac{I_{10}}{I_9} \right] = 8.3$$

$$k = G_i \times C_5 \times R_6 \times V_{ch}$$

The analog output voltage is given by

$$V_O = k \times f$$

The values of C_5 and C_6 must be such that for the highest possible input frequency, the maximum output voltage V_O does not exceed 6 V . While C_5 is charging up, the R_1 on Pin 9 is approximately $6.7 \text{ k}\Omega$. To obtain good linearity of the f/V converter, the time constant resulting from R_1 and C_5 should be considerably less ($1/5$) than the time span of the negative half-cycle for the highest possible input frequency. The amount of remaining ripple on the output voltage on Pin 10 is dependent on C_5 , C_6 and the internal charge amplification.

$$\Delta V_O = \frac{G_i \times V_{ch} \times C_5}{C_6}$$

The ripple ΔV_O can be reduced by using larger values of C_6 . However, the increasing speed will then also be reduced.

The value of this capacitor should be chosen to fit the particular control loop where it is going to be used.

Pulse Blocking

The output of pulses can be blocked by using Pin 18 (standby operation) and the system reset via the voltage monitor if $V_{18} \geq -1.25 \text{ V}$. After cycling through the switching point hysteresis, the output is released when $V_{18} \leq -1.5 \text{ V}$ followed by a soft start such as that after turn-on.

Monitoring of the rotation can be carried out by connecting an RC network to Pin 18. In the event of a short or open circuit, the triac triggering pulses are cut off by the time delay which is determined by R and C. The capacitor C is discharged via an internal resistance $R_1 = 2 \text{ k}\Omega$ with each charge transfer process of the f/V converter. If there are no more charge transfer processes, C is charged up via R until the switch-off threshold is exceeded and the triac triggering pulses are cut off. For operation without trigger pulse blocking or monitoring of the rotation, Pins 18 and 16 must be connected together.

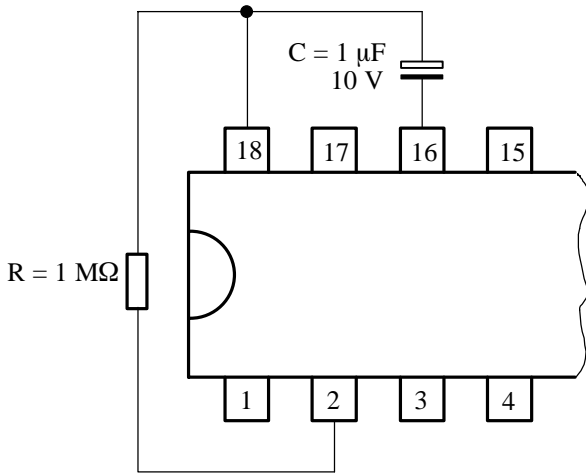

Figure 7. Operation delay

Control Amplifier (Figure 2)

The integrated control amplifier with differential input compares the set value (Pin 11) with the instantaneous value on Pin 10 and generates a regulating voltage on the output Pin 12 (together with the external circuitry on Pin 12) which always tries to hold the actual voltage at the value of the set voltages. The amplifier has a transmittance of typically $1000 \mu\text{A}/\text{V}$ and a bipolar current source output on Pin 12 which operates with typically $\pm 110 \mu\text{A}$. The amplification and frequency response are determined by R_7 , C_7 , C_8 and R_{11} (can be left out). For open-loop operation, C_4 , C_5 , R_6 , R_7 , C_7 , C_8 and R_{11} can be omitted. Pin 10 should be connected with Pin 12 and Pin 8 with Pin 2. The phase angle of the triggering pulse can be adjusted using the voltage on Pin 11. An internal limitation circuit prevents the voltage on Pin 12 from becoming more negative than $V_{16} + 1 \text{ V}$.

Load Limitation

The load limitation, with standard circuitry, provides absolute protection against overloading of the motor. The function of the load limiting takes account of the fact that motors operating at higher speeds can safely withstand larger power dissipations than at lower speeds due to the increased action of the cooling fan. Similarly, considerations have been made for short-term overloads for the motor which are, in practice, often required. These behavior are not damaging and can be tolerated.

In each positive half-cycle, the circuit measures via R_{10} the load current on Pin 14 as a potential drop across R_8 and produces a current proportional to the voltage on Pin 14. This current is available on Pin 15 and is integrated by C_9 . If, following high-current amplitudes or a large phase angle for current flow, the voltage on C_9

exceeds an internally set threshold of approximately 7.3 V (reference voltage Pin 16), a latch is set and the load limiting is turned on. A current source (sink) controlled by the control voltage on Pin 15 now draws current from Pin 12 and lowers the control voltage on Pin 12 so that the phase angle α is increased to α_{max} .

The simultaneous reduction of the phase angle during which current flows causes firstly: a reduction of the rotational speed of the motor which can even drop to zero if the angular momentum of the motor is excessively large, and secondly: a reduction of the potential on C_9 which in turn reduces the influence of the current sink on Pin 12. The control voltage can then increase again and bring down the phase angle. This cycle of action sets up a "balanced condition" between the "current integral" on Pin 15 and the control voltage on Pin 12.

Apart from the amplitude of the load current and the time during which current flows, the potential on Pin 12 and hence the rotational speed also affects the function of the load limiting. A current proportional to the potential on Pin 10 gives rise to a voltage drop across R_{10} , via Pin 14, so that the current measured on Pin 14 is smaller than the actual current through R_8 .

This means that higher rotational speeds and higher current amplitudes lead to the same current integral. Therefore, at higher speeds, the power dissipation must be greater than that at lower speeds before the internal threshold voltage on Pin 15 is exceeded. The effect of speed on the maximum power is determined by the resistor R_{10} and can therefore be adjusted to suit each individual application.

If, after the load limiting has been turned on, the momentum of the load sinks below the "o-momentum" set using R_{10} , then V_{15} will be reduced. V_{12} can then increase again so that the phase angle is reduced. A smaller phase angle corresponds to a larger momentum of the motor and hence the motor runs up - as long as this is allowed by the load momentum. For an already rotating machine, the effect of rotation on the measured "current integral" ensures that the power dissipation is able to increase with the rotational speed. The result is a current-controlled acceleration run-up which ends in a small peak of acceleration when the set point is reached. The latch of the load limiting is simultaneously reset. The speed of the motor is then again under control and is capable of carrying its full load. The above mentioned peak of acceleration depends upon the ripple of actual speed voltage. A large amount of ripple also leads to a large peak of acceleration.

The measuring resistor R_8 should have a value which ensures that the amplitude of the voltage across it does not exceed 600 mV.

Design Hints

Practical trials are normally needed for the exact determination of the values of the relevant components in the load limiting. To make this evaluation easier, the

following table shows the effect of the circuitry on the important parameters of the load limiting and summarizes the general tendencies.

Parameters	Component		
	R ₁₀ Increasing	R ₉ Increasing	C ₉ Increasing
P _{max}	increases	decreases	n.e.
P _{min}	increases	decreases	n.e.
P _{max} / min	increases	n.e.	n.e.
t _d	n.e.	increases	increases
t _r	n.e.	increases	increases

P_{max} – maximum continuous power dissipation

P_{min} – power dissipation with no rotation

t_d – operation delay time

t_r – recovery time

n.e. – no effect

P₁ = f_(n) n ≠ 0

P₁ = f_(n) n = 0

Pulse-Output Stage

The pulse-output stage is short-circuit protected and can typically deliver currents of 125 mA. For the design of smaller triggering currents, the function I_{GT} = f(R_{GT}) can be taken from figure 20.

Automatic Retriggering

The variable automatic retriggering prevents half cycles without current flow, even if the triac is turned off earlier, e.g., due to a collector which is not exactly centered (brush lifter) or in the event of unsuccessful triggering. If necessary, another triggering pulse is generated after a time lapse which is determined by the repetition rate set by resistance between Pin 5 and Pin 3 (R₅₋₃). With the maximum repetition rate (Pin 5 directly connected to Pin 3), the next attempt to trigger comes after a pause of 4.5 t_p and this is repeated until either the triac fires or the half cycle finishes. If Pin 5 is not connected, then only one trigger pulse per half cycle is generated. Because the value of R₅₋₃ determines the charging current of C₂, any repetition rate set using R₅₋₃ is only valid for a fixed value of C₂.

General Hints and Explanation of Terms

To ensure safe and trouble-free operation, the following points should be taken into consideration when circuits are being constructed or in the design of printed circuit boards.

- The connecting lines from C₂ to Pin 7 and Pin 2 should be as short as possible. The connection to Pin 2 should not carry any additional high current such as the load current. When selecting C₂, a low temperature coefficient is desirable.
- The common (earth) connections of the set-point generator, the tacho generator and the final interference suppression capacitor C₄ of the f/V converter should not carry load current.
- The tacho generator should be mounted without influence by strong stray fields from the motor.
- The connections from R₁₀ and C₅ should be as short as possible.

To achieve a high noise immunity, a maximum ramp voltage of 6 V should be used.

The typical resistance R_φ can be calculated from I_φ as follows:

$$R_{\phi} (\text{k}\Omega) = \frac{T(\text{ms}) \times 1.13(\text{V}) \times 10^3}{C(\text{nF}) \times 6(\text{V})}$$

T = Period duration for mains frequency
(10 ms at 50 Hz)

C_φ = Ramp capacitor, max. ramp voltage 6 V
and constant voltage drop at R_φ = 1.13 V.

A 10% lower value of R_φ (under worst case conditions) is recommended.

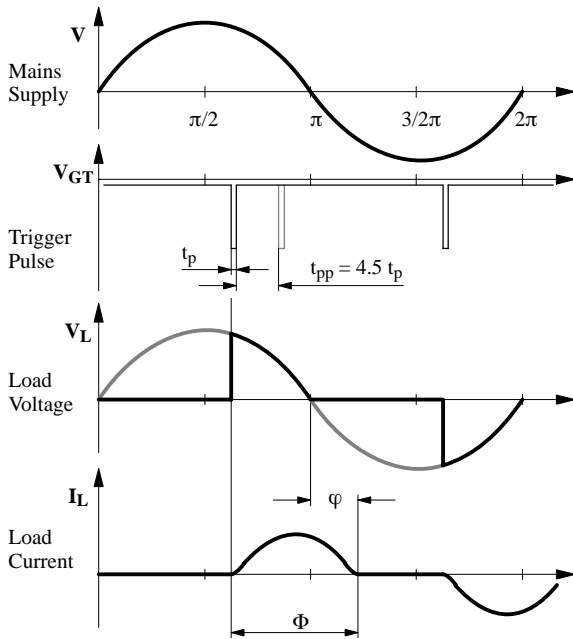

Figure 8. Explanation of terms in phase relationship

Design Calculations for Mains Supply

The following equations can be used for the evaluation of the series resistor R_1 for worst case conditions:

$$R_{1\max} = 0.85 \frac{V_{M\min} - V_{S\max}}{2 I_{\text{tot}}} \quad R_{1\min} = \frac{V_M - V_{S\min}}{2 I_{S\max}}$$

$$P_{(R1\max)} = \frac{(V_{M\max} - V_{S\min})^2}{2 R_1}$$

where:

V_M = Mains voltage

V_S = Supply voltage on Pin 3

I_{tot} = Total DC current requirement of the circuit
 $= I_S + I_p + I_x$

$I_{S\max}$ = Current requirement of the IC in mA

I_p = Average current requirement of the triggering pulse

I_x = Current requirement of other peripheral components

R_1 can be easily evaluated from the figures 22 to 24.

Absolute Maximum Ratings

Reference point Pin 2, unless otherwise specified

Parameters		Symbol	Value	Unit
Current requirement	Pin 3	$-I_S$	30	mA
	$t \leq 10 \mu s$	$-i_s$	100	mA
Synchronization current	Pin 1	I_{syncI}	5	mA
	Pin 17	I_{syncV}	5	mA
	$t < 10 \mu s$ Pin 1	$\pm I_I$	35	mA
	$t < 10 \mu s$ Pin 17	$\pm I_I$	35	mA
f/V converter		Pin 8		
Input current		I_I	3	mA
	$t < 10 \mu s$	$\pm I_I$	13	mA
Load limiting		Pin 14		
Limiting current, negative half wave		I_I	5	mA
	$t < 10 \mu s$	I_I	35	mA
Input voltage	Pin 14	$\pm V_i$	1	V
	Pin 15	$-V_I$	$ V_{16} $ to 0	V
Phase control				
Input voltage	Pin 12	$-V_I$	0 to 7	V
Input current	Pin 12	$\pm I_I$	500	μA
	Pin 6	$-I_I$	1	mA
Soft start				
Input voltage	Pin 13	$-V_I$	$ V_{16} $ to 0	V
Pulse output				
Reverse voltage	Pin 4	V_R	V_S to 5	V
Pulse blocking				
Input voltage	Pin 18	$-V_I$	$ V_{16} $ to 0	V
Amplifier				
Input voltage	Pin 11	V_I	0 to V_S	V
Pin 9 open	Pin 10	$-V_I$	$ V_{16} $ to 0	V
Reference voltage source				
Output current	Pin 16	I_o	7.5	mA
Storage temperature range		T_{stg}	-40 to +125	$^{\circ}C$
Junction temperature		T_j	125	$^{\circ}C$
Ambient temperature range		T_{amb}	-10 to +100	$^{\circ}C$

Thermal Resistance

Parameters		Symbol	Maximum	Unit
Junction ambient	DIP18	R_{thJA}	120	K/W
	SO16 on p.c.	R_{thJA}	180	K/W
	SO16 on ceramic	R_{thJA}	100	K/W

Electrical Characteristics

$-V_S = 13.0\text{ V}$, $T_{\text{amb}} = 25^\circ\text{C}$, reference point Pin 2, unless otherwise specified

Parameters	Test Conditions / Pins	Symbol	Min.	Typ.	Max.	Unit	
Supply voltage for mains operation	Pin 3	$-V_S$	13.0		V_{Limit}	V	
Supply voltage limitation	$-I_S = 4\text{ mA}$ $-I_S = 30\text{ mA}$	Pin 3	$-V_S$	14.6		16.6	V
			$-V_S$	14.7		16.8	V
DC current requirement	$-V_S = 13.0\text{ V}$	Pin 3	I_S	1.2	2.5	3.0	mA
Reference voltage source	$-I_L = 10\text{ }\mu\text{A}$ $-I_L = 5\text{ mA}$	Pin 16	$-V_{\text{Ref}}$	8.6	8.9	9.2	V
			$-V_{\text{Ref}}$	8.3		9.1	V
Temperature coefficient		Pin 16	$-TC_{V_{\text{Ref}}}$		0.5		mV/K
Voltage monitoring							
Turn-on threshold		Pin 3	$-V_{\text{SON}}$	11.2	13.0		V
Turn-off threshold		Pin 3	$-V_{\text{SOFF}}$	9.9	10.9		V
Phase-control currents							
Synchronization current		Pin 1	$\pm I_{\text{syncI}}$	0.35		2.0	mA
		Pin 17	$\pm I_{\text{syncV}}$	0.35		2.0	mA
Voltage limitation	$\pm I_L = 5\text{ mA}$	Pins 1 and 17	$\pm V_I$	1.4	1.6	1.8	V
Reference ramp , see figure 9							
Charge current	$I_7 = f(R_6)$; $R_6 = 50\text{ k to }1\text{ M}\Omega$	Pin 7	I_7	1	20		μA
R_ϕ -reference voltage	$\alpha \geq 180^\circ\text{C}$	Pins 6 and 3	$V_{\phi\text{Ref}}$	1.06	1.13	1.18	V
Temperature coefficient		Pin 6	$TC_{V_{\phi\text{Ref}}}$		0.5		mV/K
Pulse output , see figure 20							
		Pin 4					
Output pulse current	$R_{\text{GT}} = 0$, $V_{\text{GT}} = 1.2\text{ V}$		I_o	100	155	190	mA
Reverse current			I_{or}		0.01	3.0	μA
Output pulse width	$C_\phi = 10\text{ nF}$		t_p		80		μs
Amplifier							
Common-mode signal range		Pins 10 and 11	$V_{10, 11}$	V_{16}		-1	V
Input bias current		Pin 11	I_{IO}		0.01	1	μA
Input offset voltage		Pins 10 and 11	V_{10}		10		mV
Output current		Pin 12	$-I_O$	75	110	145	μA
			$+I_O$	88	120	165	μA
Short circuit forward, transmittance	See figure 16 $I_{12} = f(V_{10-11})$	Pin 12	Y_f		1000		$\mu\text{A/V}$
Pulse blocking, tacho monitoring							
		Pin 18					
Logic-on			$-V_{\text{TON}}$	3.7	1.5		V
Logic-off			$-V_{\text{TOFF}}$		1.25	1.0	V
Input current	$V_{18} = V_{\text{TOFF}} = 1.25\text{ V}$ $V_{18} = V_{16}$		I_I		0.3	1	μA
			I_I	14.5			μA
Output resistance			R_O	1.5	6	10	k Ω

Electrical Characteristics (continued)

$-V_S = 13.0\text{ V}$, $T_{\text{amb}} = 25^\circ\text{C}$, reference point Pin 2, unless otherwise specified

Parameters	Test Conditions / Pins	Symbol	Min.	Typ.	Max.	Unit
Frequency-to-voltage converter Pin 8						
Input bias current		I_{IB}		0.6	2	μA
Input voltage limitation	See figure 15 $I_{\text{I}} = -1\text{ mA}$ $I_{\text{I}} = +1\text{ mA}$	$-V_{\text{I}}$ $+V_{\text{I}}$	660 7.25		750 8.05	mV V
Turn-on threshold		$-V_{\text{TON}}$		100	150	mV
Turn-off threshold		$-V_{\text{TOFF}}$	20	50		mV
Charge amplifier						
Discharge current	See figure 2, $C_5 = 1\text{ nF}$, Pin 9	I_{dis}		0.5		mA
Charge transfer voltage	Pins 9 to 16	V_{ch}	6.50	6.70	6.90	V
Charge transfer gain	I_{10}/I_9 Pins 9 and 10	G_{i}	7.5	8.3	9.0	
Conversion factor	See figure 2 $C_5 = 1\text{ nF}$, $R_6 = 100\text{ k}\Omega$	K		5.5		mV/Hz
Output operating range	Pins 10 to 16	V_{O}		0-6		V
Linearity				± 1		%
Soft start , see figures 10, 12, f/v-converter non-active						
Starting current	$V_{13} = V_{16}$, $V_8 = V_2$ Pin 13	I_{O}	20	45	55	μA
Final current	$V_{13} = 0.5$ Pin 13	I_{O}	50	85	130	μA
f/v-converter active , see figures 11, 13, 14						
Starting current	$V_{13} = V_{16}$ Pin 13	I_{O}	2	4	7	μA
Final current	$V_{13} = 0.5$	I_{O}	30	55	80	μA
Discharge current	Restart pulse Pin 13	I_{O}	0.5	3	10	mA
Automatic retriggering , see figure 21 Pin 5						
Repetition rate	$R_{5-3} = 0$	t_{pp}	3	4.5	6	t_{p}
	$R_{5-3} = 15\text{ k}\Omega$	t_{pp}		20		t_{p}
Load limiting , see figures 17, 18, 19 Pin 14						
Operating voltage range	Pin 14	V_{I}	-1.0		1.0	V
Offset current	$V_{10} = V_{16}$ Pin 14	I_{O}	5		12	μA
	$V_{14} = V_2$ via $1\text{ k}\Omega$ Pin 15-16	I_{O}		0.1	1.0	μA
Input current	$V_{10} = 4.5\text{ V}$ Pin 14	I_{I}	60	90	120	μA
Output current	$V_{14} = 300\text{ mV}$ Pin 15-16	I_{O}	110		140	μA
Overload ON	Pin 15-16	V_{TON}	7.05	7.4	7.7	V

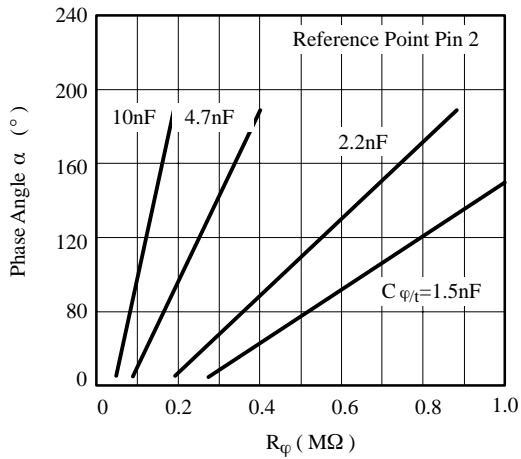

Figure 9. Ramp control

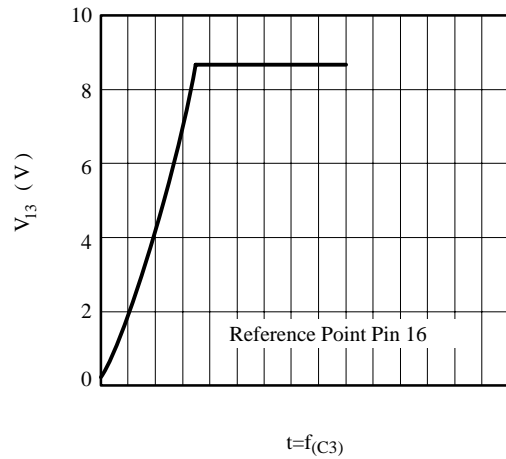

Figure 12. Soft-start voltage (f/V-converter non-active)

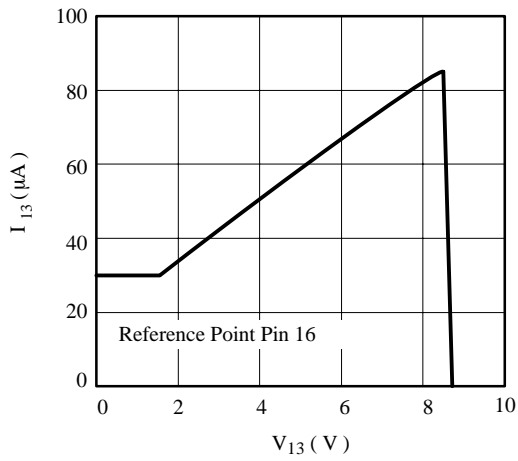

Figure 10. Soft-start charge current (f/V-converter non-active)

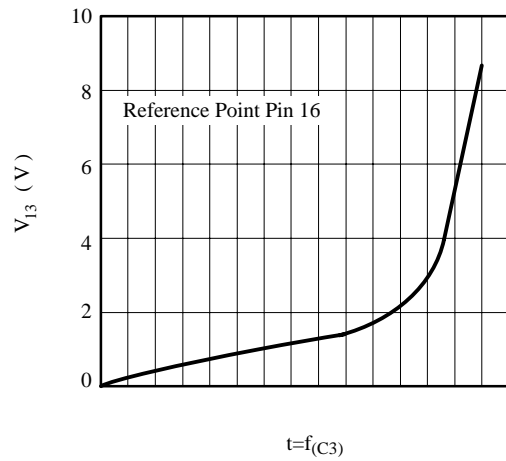

Figure 13. Soft-start voltage (f/V-converter active)

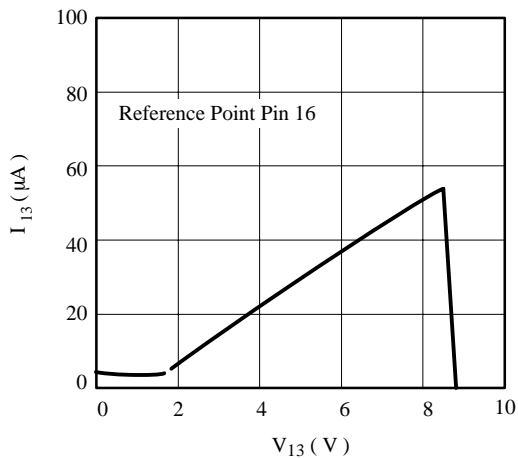

Figure 11. Soft-start charge current (f/V-converter active)

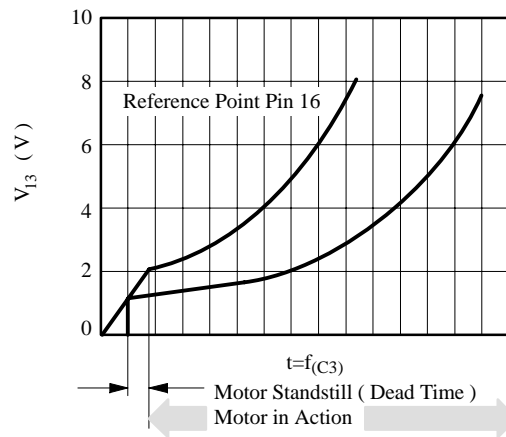

Figure 14. Soft-start function

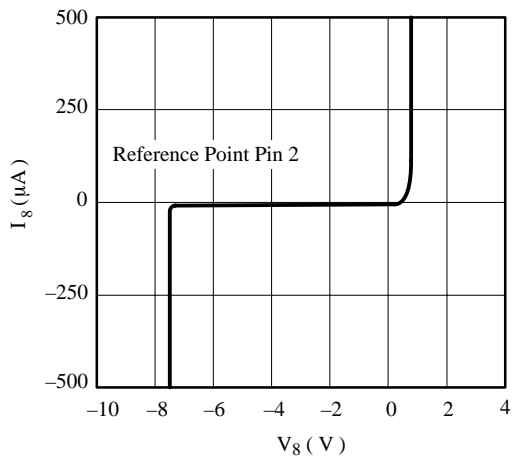

Figure 15. f/V-converter voltage limitation

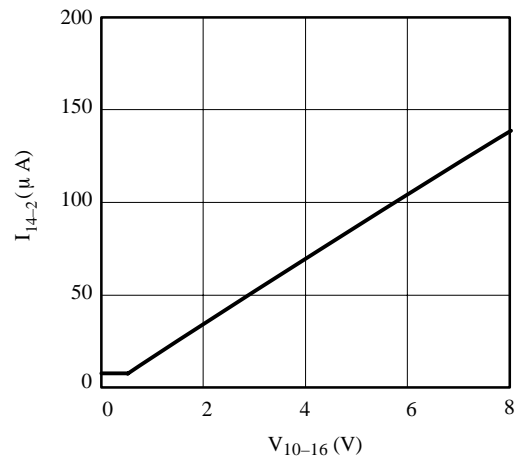

Figure 18. Load limit control f/V dependency

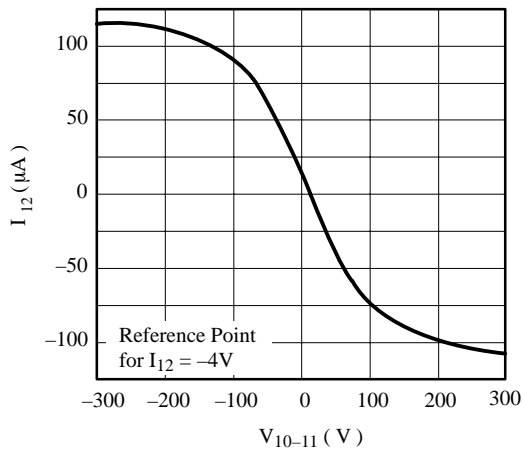

Figure 16. Amplifier output characteristic

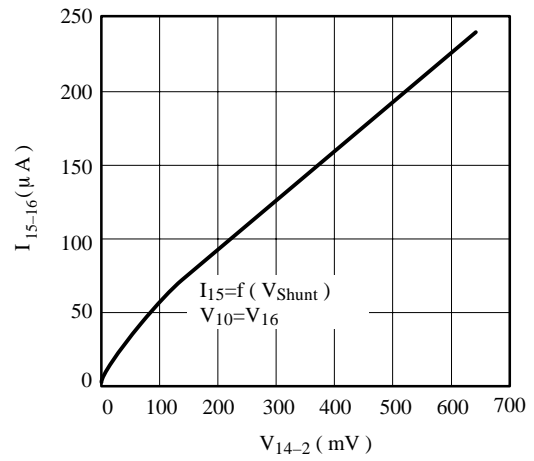

Figure 19. Load current detection

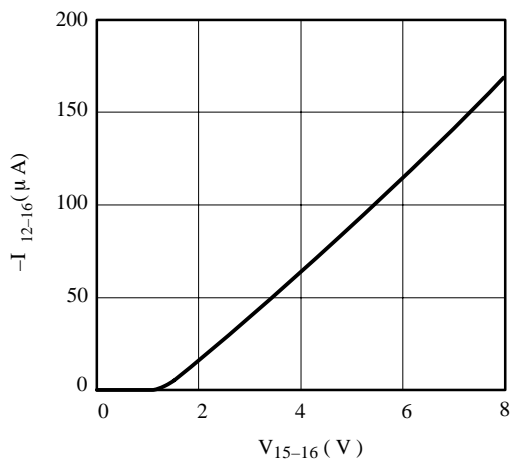

Figure 17. Load limit control

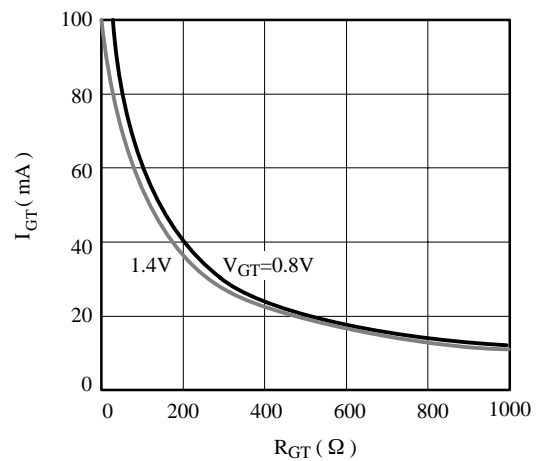

Figure 20. Pulse output

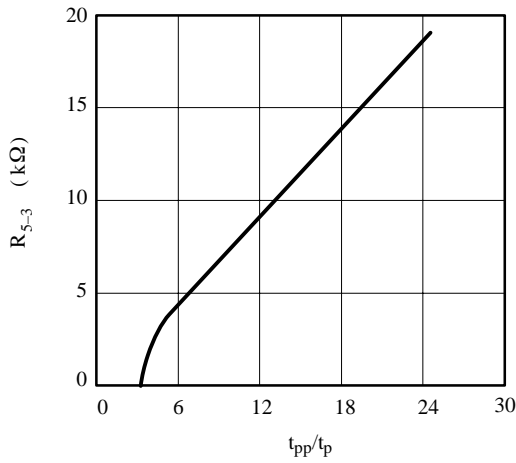

Figure 21. Automatic retriggering repetition rate

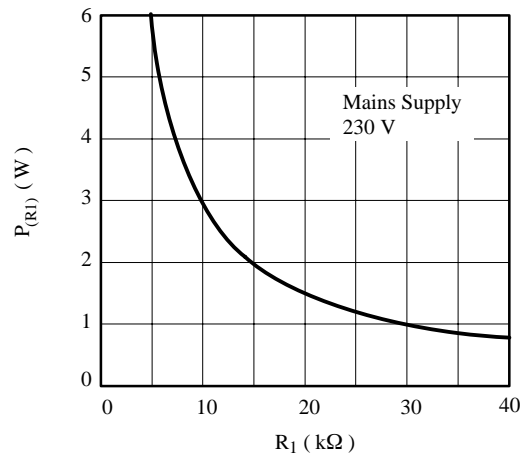

Figure 23. Power dissipation of R_1

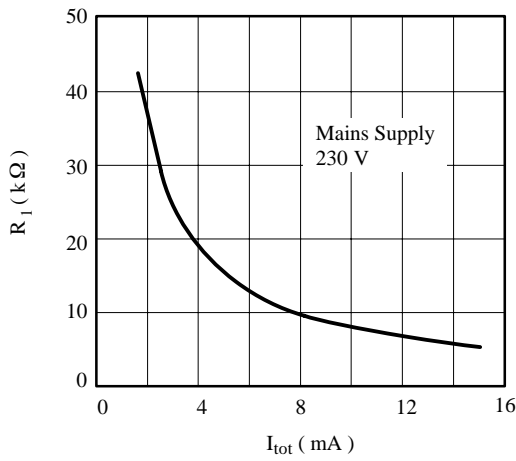

Figure 22. Determination of R_1

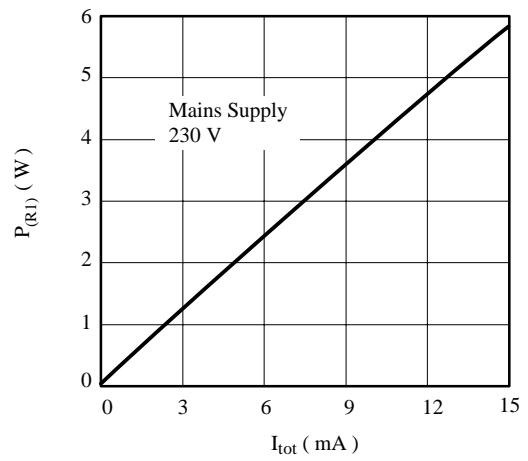

Figure 24. Power dissipation of R_1 according to current consumption

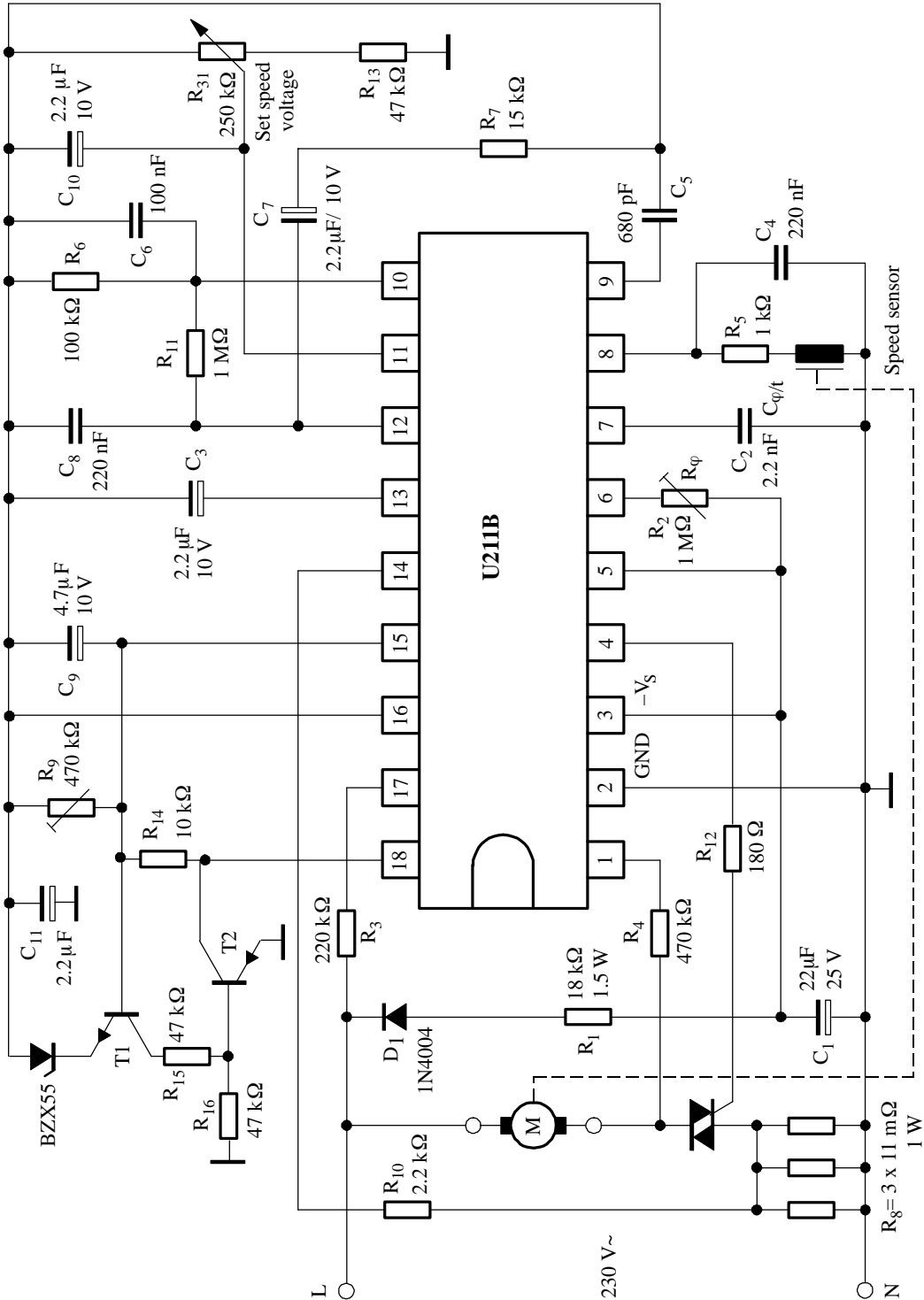

Figure 25. Speed control, automatic retriggering, load switch-off, soft start

The switch-off level at maximum load shows in principle the same speed dependency as the original version (see figure 2), but when reaching the maximum load, the motor is switched off completely.

This function is effected by the thyristor (formed by T1 and T2) which ignites when the voltage at Pin 15 reaches typ. 7.4 V (reference point Pin 16). The circuit is thereby switched in the "stand-by mode" over the release Pin 18.

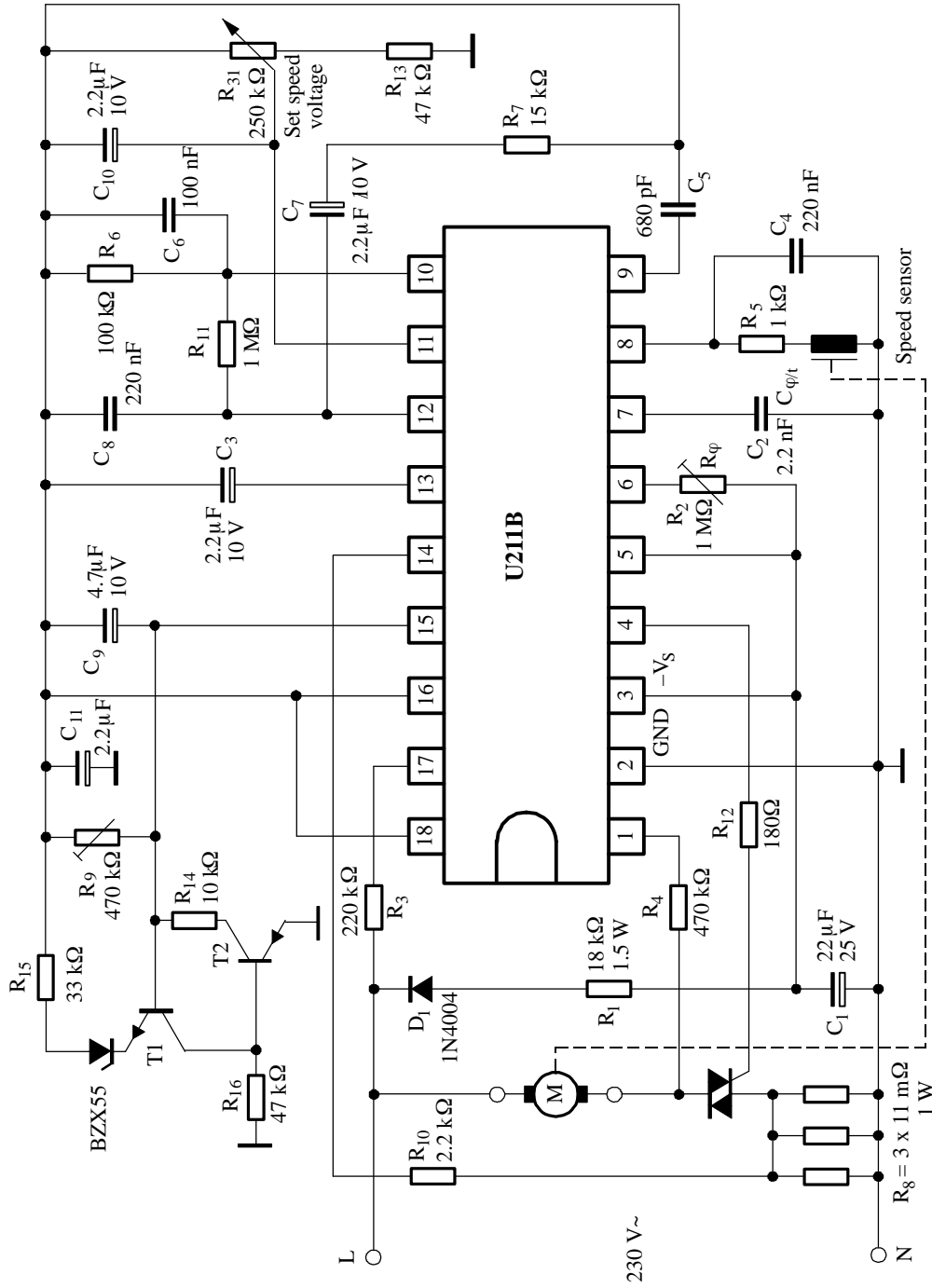

Figure 26. Speed control, automatic retriggering, load switch-off, soft start

The maximum load regulation shows the principle in the same speed dependency as the original version (see figure 2). When reaching the maximum load, the control unit is turned to α_{max} , adjustable with R_2 . Then only I_0 flows. This function is effected by the thyristor, formed by T_1 and T_2 which ignites as soon as the voltage at Pin 15 reaches ca. 6.8 V (reference point Pin 16). The potential

at Pin 15 is lifted and kept by R_{14} over the internally operating threshold whereby the maximum load regulation starts and adjusts the control unit constantly to α_{max} (I_0), inspite of a reduced load current. The motor shows that the circuit is still in operation in the matter of a quiet buzzing sound.

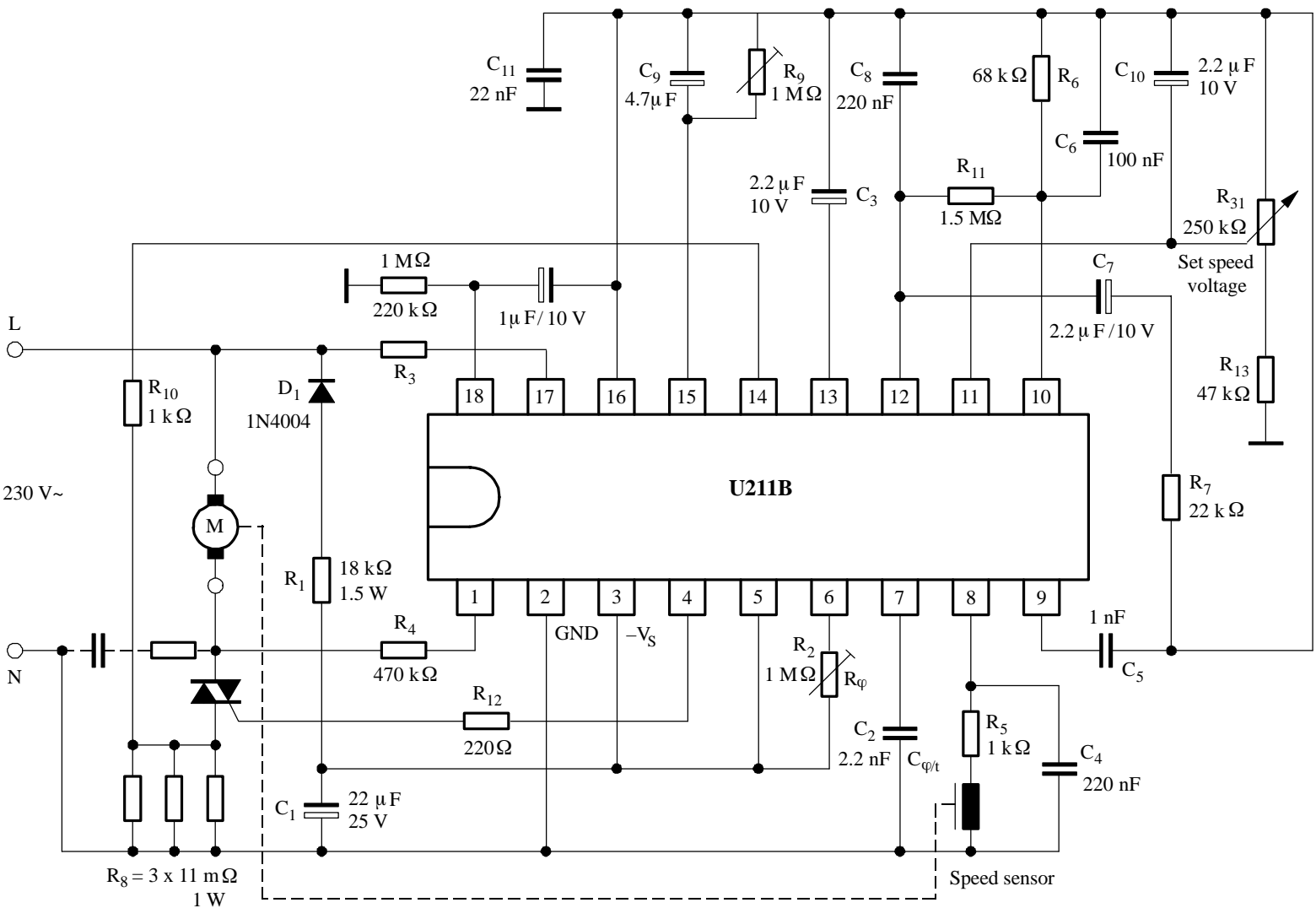

Figure 27. Speed control, automatic retriggering, load limiting, soft start, tachometer control

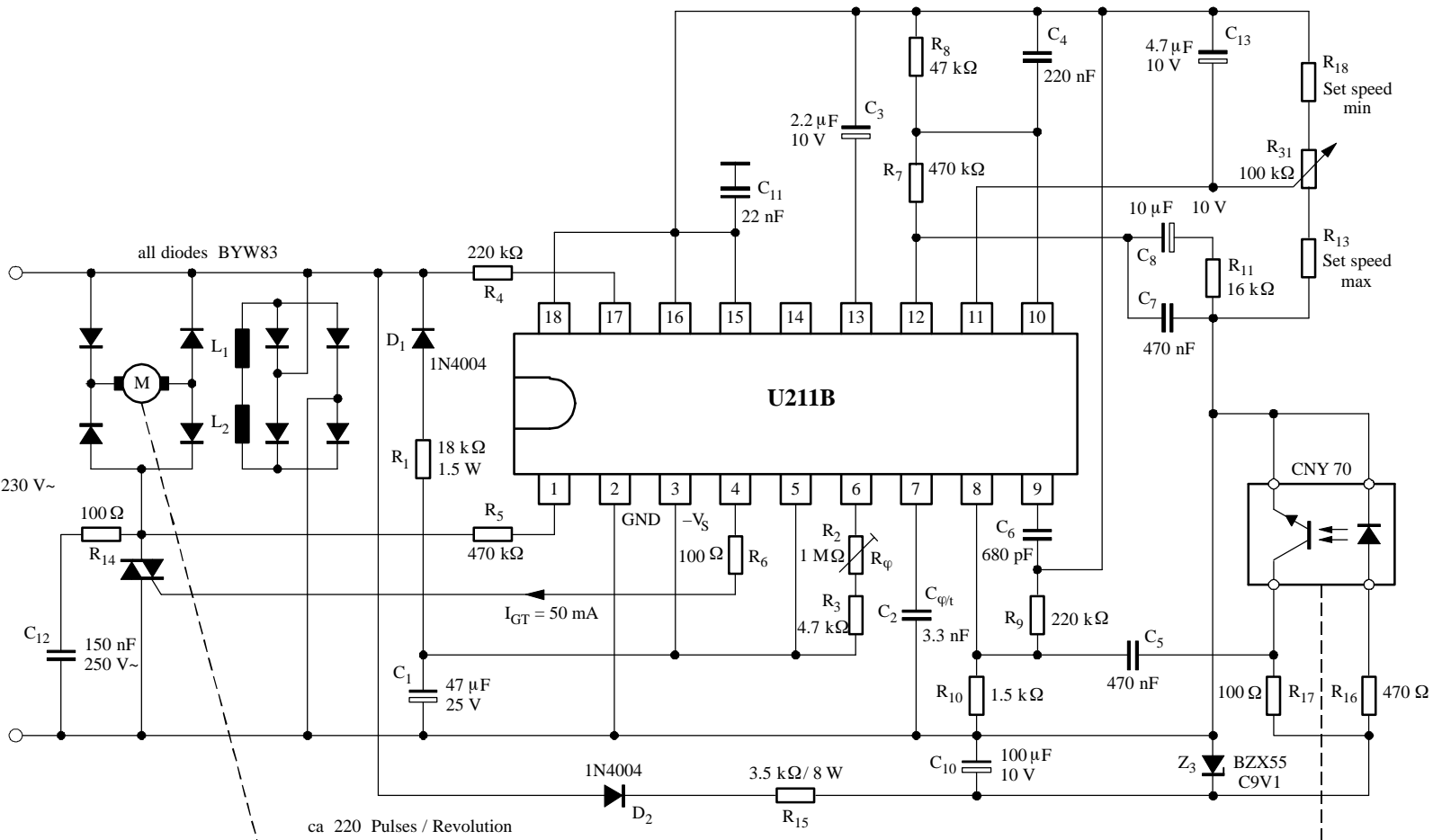

Figure 28. Speed control with reflective opto coupler CNY70 as emitter

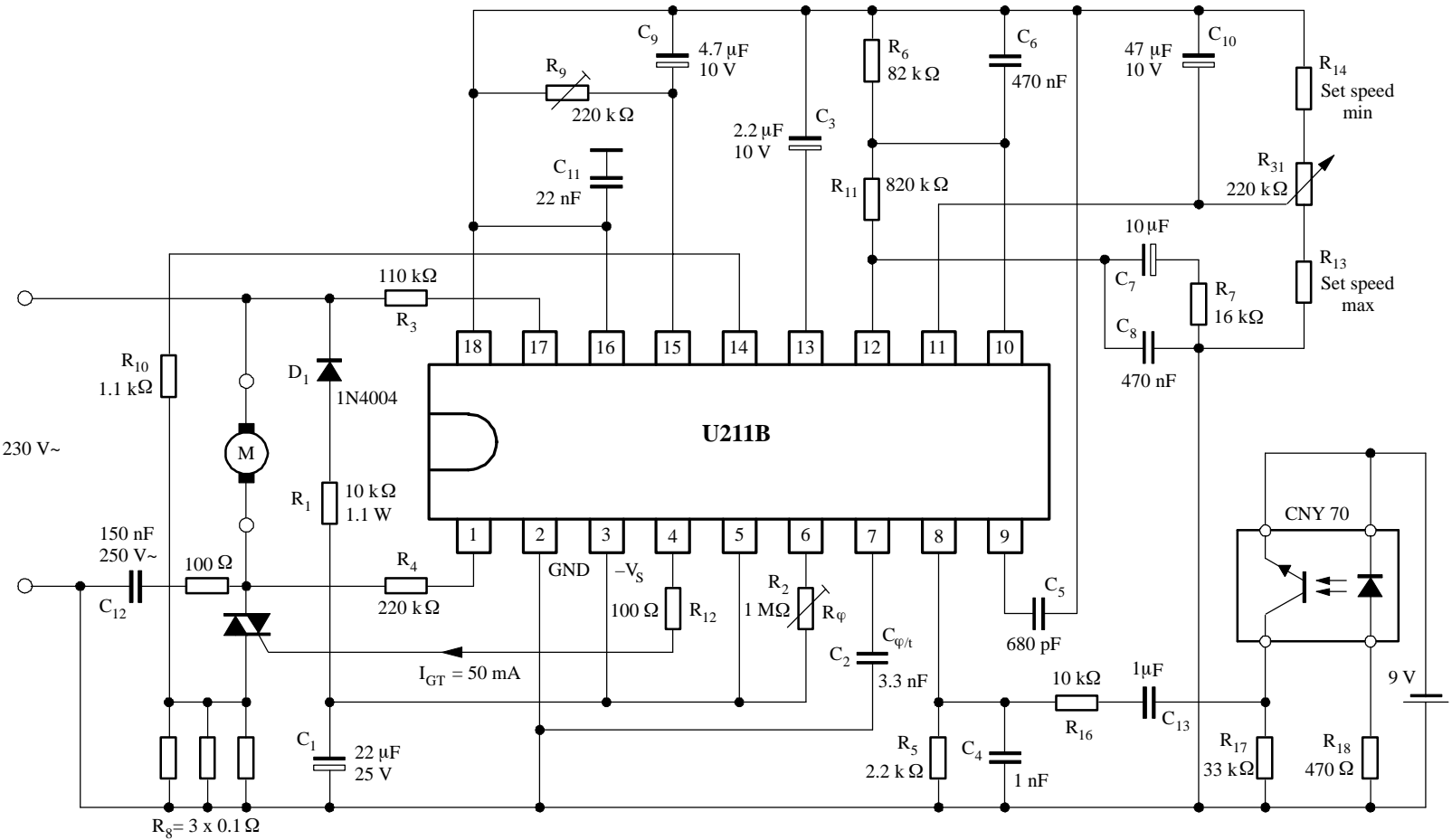

Figure 29. Speed control, max. load control with reflective opto coupler CNY70 as emitter

The circuit is designed as a speed control based on the reflection-coupled principle with 4 periods per revolution and a max. speed of 30.000 rpm. The separation of the coupler from the rotating aperture should be about 1 mm approximately. In this experimental circuit, the power supply for the coupler was provided externally because of the relatively high current consumption.

Instructions for adjusting:

- In the initial adjustment of the phase-control circuit, R_2 should be adjusted so that when $R_{14} = 0$ and R_{31} are in min. position, the motor just turns.
- The speed can now be adjusted as desired by means of R_{31} between the limits determined by R_{13} and R_{14} .
- The switch-off power of the limiting-load control can be set by R_9 . The lower R_9 , the higher the switch-off power.

Package Information

Package DIP18

Dimensions in mm

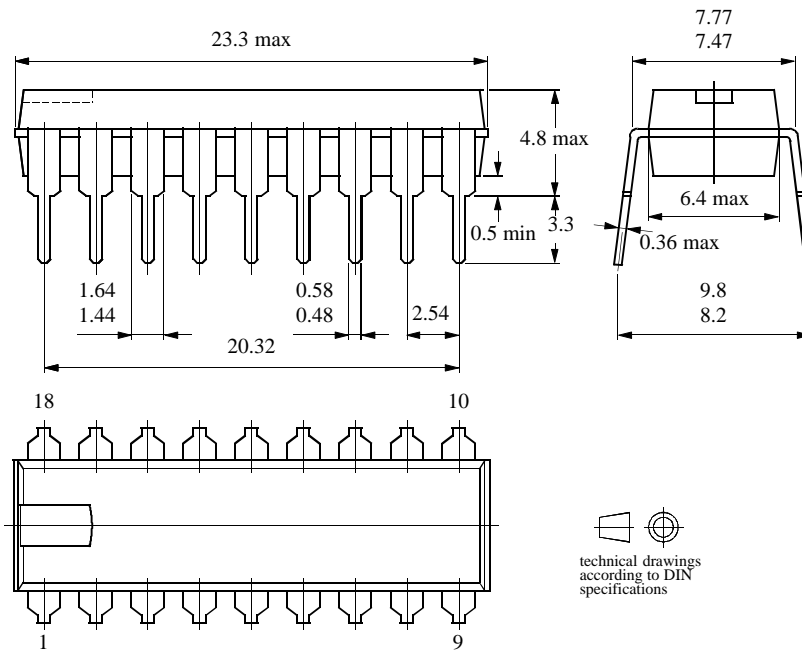

Package SO16

Dimensions in mm

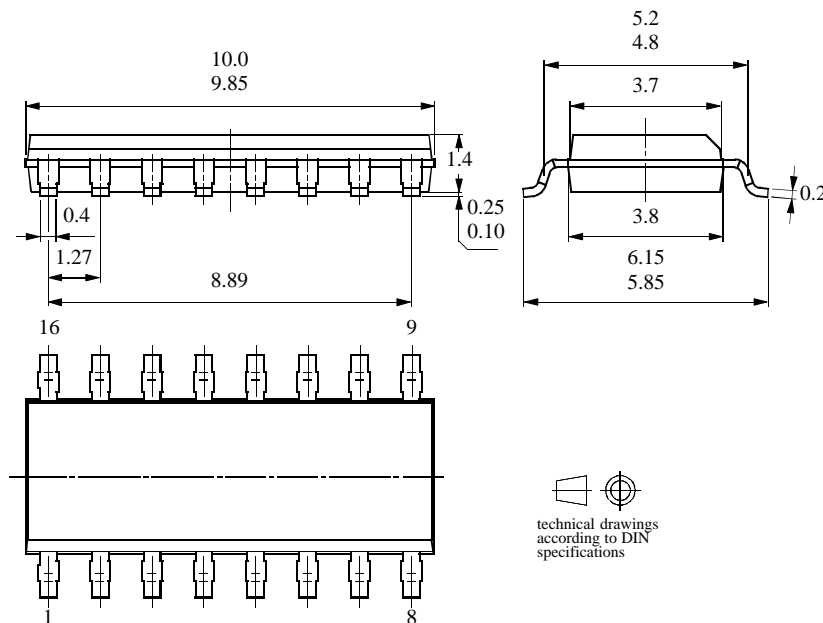

Ozone Depleting Substances Policy Statement

It is the policy of **Atmel Germany GmbH** to

1. Meet all present and future national and international statutory requirements.
2. Regularly and continuously improve the performance of our products, processes, distribution and operating systems with respect to their impact on the health and safety of our employees and the public, as well as their impact on the environment.

It is particular concern to control or eliminate releases of those substances into the atmosphere which are known as ozone depleting substances (ODSs).

The Montreal Protocol (1987) and its London Amendments (1990) intend to severely restrict the use of ODSs and forbid their use within the next ten years. Various national and international initiatives are pressing for an earlier ban on these substances.

Atmel Germany GmbH has been able to use its policy of continuous improvements to eliminate the use of ODSs listed in the following documents.

1. Annex A, B and list of transitional substances of the Montreal Protocol and the London Amendments respectively
2. Class I and II ozone depleting substances in the Clean Air Act Amendments of 1990 by the Environmental Protection Agency (EPA) in the USA
3. Council Decision 88/540/EEC and 91/690/EEC Annex A, B and C (transitional substances) respectively.

Atmel Germany GmbH can certify that our semiconductors are not manufactured with ozone depleting substances and do not contain such substances.

We reserve the right to make changes to improve technical design and may do so without further notice.

Parameters can vary in different applications. All operating parameters must be validated for each customer application by the customer. Should the buyer use Atmel Wireless & Microcontrollers products for any unintended or unauthorized application, the buyer shall indemnify Atmel Wireless & Microcontrollers against all claims, costs, damages, and expenses, arising out of, directly or indirectly, any claim of personal damage, injury or death associated with such unintended or unauthorized use.

Data sheets can also be retrieved from the Internet: <http://www.atmel-wm.com>

Atmel Germany GmbH, P.O.B. 3535, D-74025 Heilbronn, Germany
Telephone: 49 (0)7131 67 2594, Fax number: 49 (0)7131 67 2423