

■ Features

- 3.5V to 20V DC operation voltage
- Temperature compensation
- Wide operating voltage range
- Open-Collector pre-driver
- 25mA maximum sinking output current.
- Reverse polarity protection
- Package: SIP3, SOT23

■ Applications

- Brush-less DC Motor
- Brush-less DC Fan
- Revolution counting
- Speed measurement

■ General Description

ATS177 is an integrated Hall effect latched sensor designed for electronic commutation of brush-less DC motor applications. The device includes an on-chip Hall voltage generator for magnetic sensing, a comparator that amplifies the Hall voltage, and a schmitt trigger to provide switching hysteresis for noise rejection, and open-collector output. An internal bandgap regulator is used to provide temperature compensated supply voltage for internal circuits and allows a wide operating supply range.

If a magnetic flux density larger than threshold B_{op} , DO is turned on(low). The output state is held until a magnetic flux density reversal falls below B_{rp} causing DO to be turned off (high).

■ Ordering Information

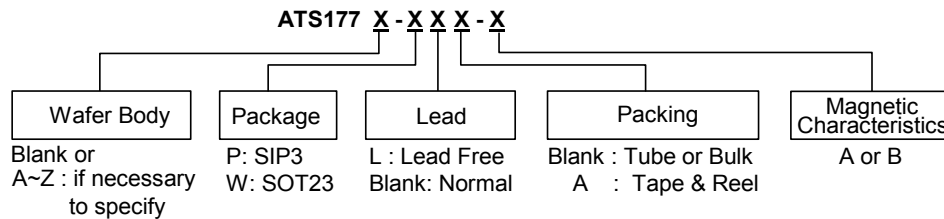

■ Typical Application Circuit

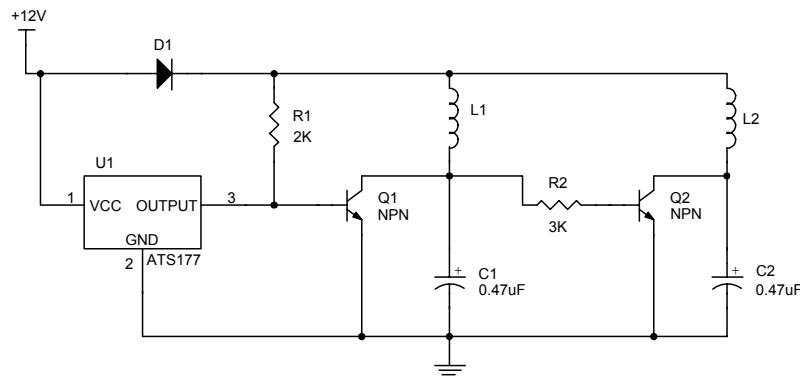

Brush-less DC Fan

■ **Functional Block Diagrams**

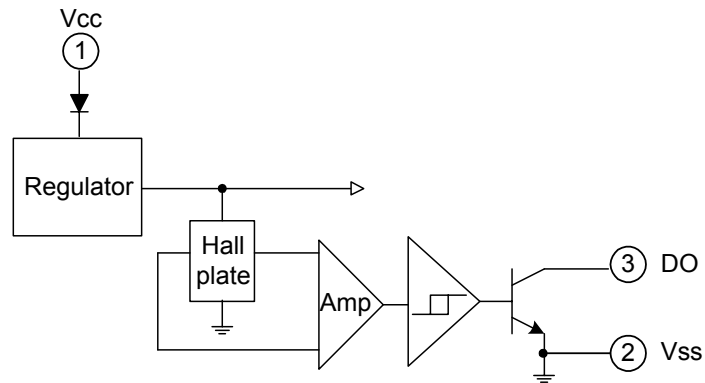

■ **Pin Descriptions**

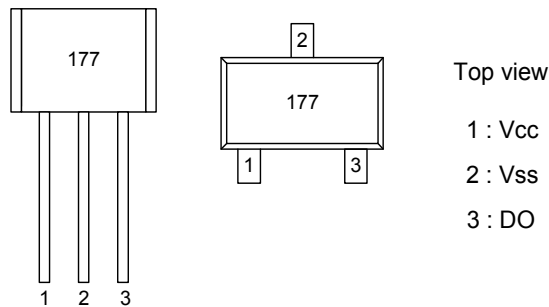

Name	P/I/O	Pin #	Description
Vcc	P	1	Positive power supply
Vss	P	2	Ground
DO	O	3	Digital output

■ **Absolute Maximum Ratings** (at Ta=25°C)

Characteristics		Symbol	Values	Unit
Supply voltage		V _{CC}	20	V
Reverse Vcc Polarity Voltage		V _{RCC}	-20	V
Magnetic flux density		B	Unlimited	
Output OFF Voltage		V _{ce}	30	V
Output "on" current	Continuous	I _c	25	mA
Operating temperature range		T _a	-20~+85	°C
Storage temperature range		T _s	-65~+150	°C
Maximum Junction Temp.		T _j	175	°C
Package Power Dissipation	SIP-3L	P _d	400	mW
	SOT23-3L		200	mW

■ **Electrical Characteristics** (Ta=+ 25°C)

Characteristic	Symbol	Test Conditions	Min	Typ	Max	Units
Supply Voltage	V _{cc}	—	3.5	-	20	V
Output Saturation Voltage	V _{ce(sat)}	V _{cc} =14V, I _c =20mA	-	300	700	mV
Output Leakage Current	I _{cex}	V _{ce} =14V, V _{cc} =14V	-	<0.1	10	uA
Supply Current	I _{cc}	V _{cc} =20V, Output Open	-	5	10	mA
Output Rise Time	t _r	V _{cc} =14V, R _L =820Ω, CL=20Pf	-	0.3	1.5	us
Output Falling Time	t _f	V _{cc} =14V, R _L =820Ω, CL=20pF	-	0.3	1.5	us

■ **Test Circuit**

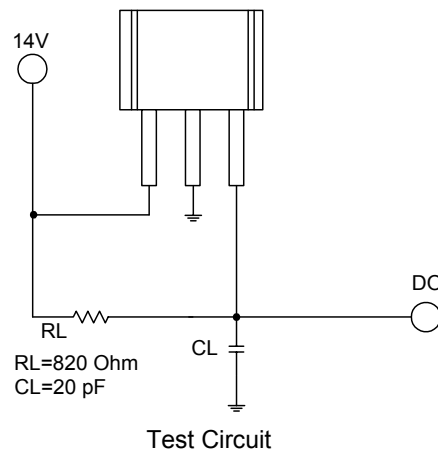

■ **Magnetic Characteristics** (Ta= 25°C)

(1mT=10Gauss)

A grade

Parameter	Symbol	Min.	Typ.	Max.	Unit
Operate Point	Bop	5	-	70	Gauss
Release Point	Brp	-70	-	-5	Gauss
Hysteresis	Bhys	-	80	-	Gauss

B grade

Parameter	Symbol	Min.	Typ.	Max.	Unit
Operate Point	Bop	-	-	100	Gauss
Release Point	Brp	-100	-	-	Gauss
Hysteresis	Bhys	-	80	-	Gauss

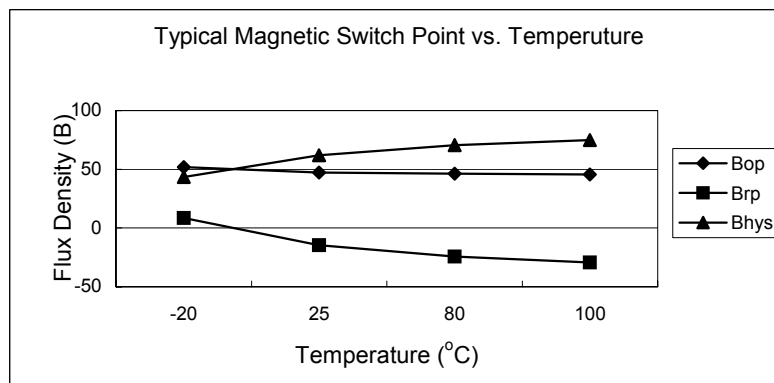
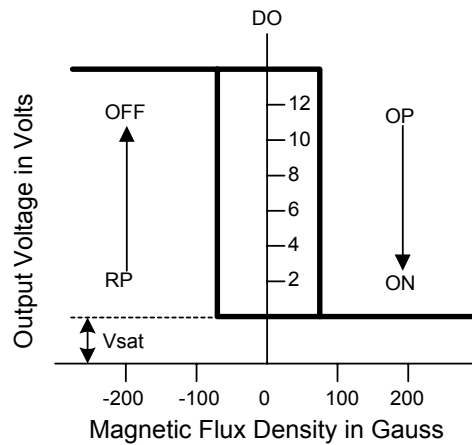

■ **Marking Information**

(1) SOT23

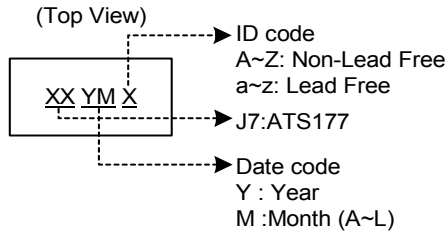

(2) SIP3

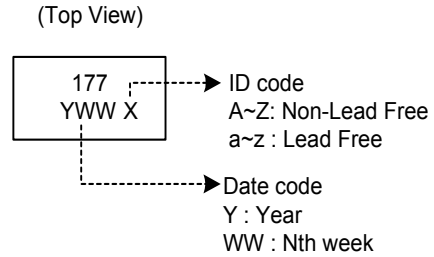

■ **Package Information** (unit: mm)

(1)Package Type: SIP-3L

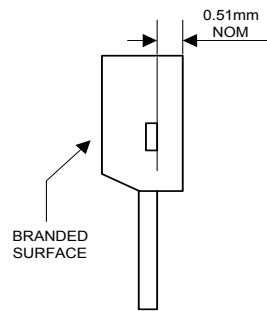

Active Area Depth

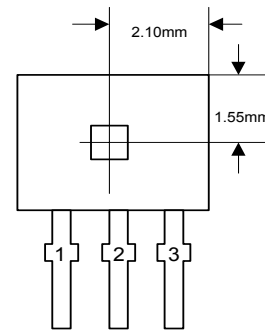

Sensor Location

Package Dimension

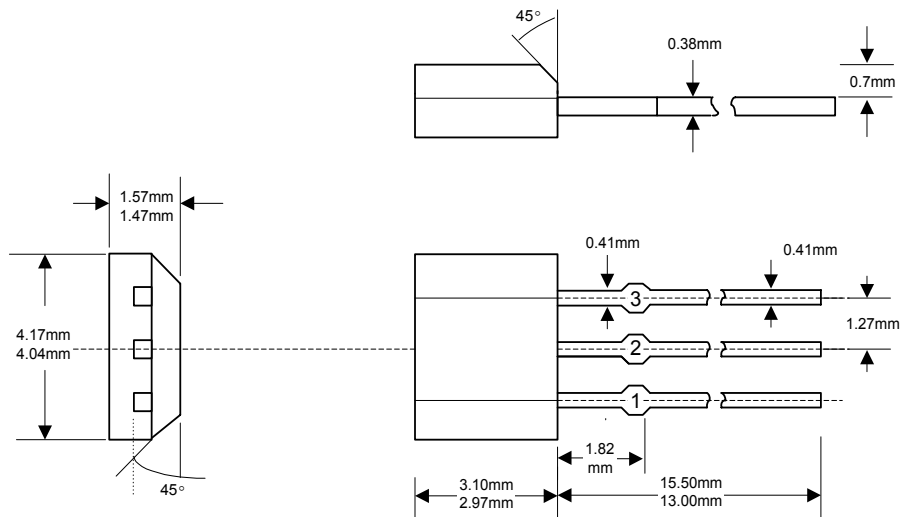

(2)Package Type: SOT23-3L

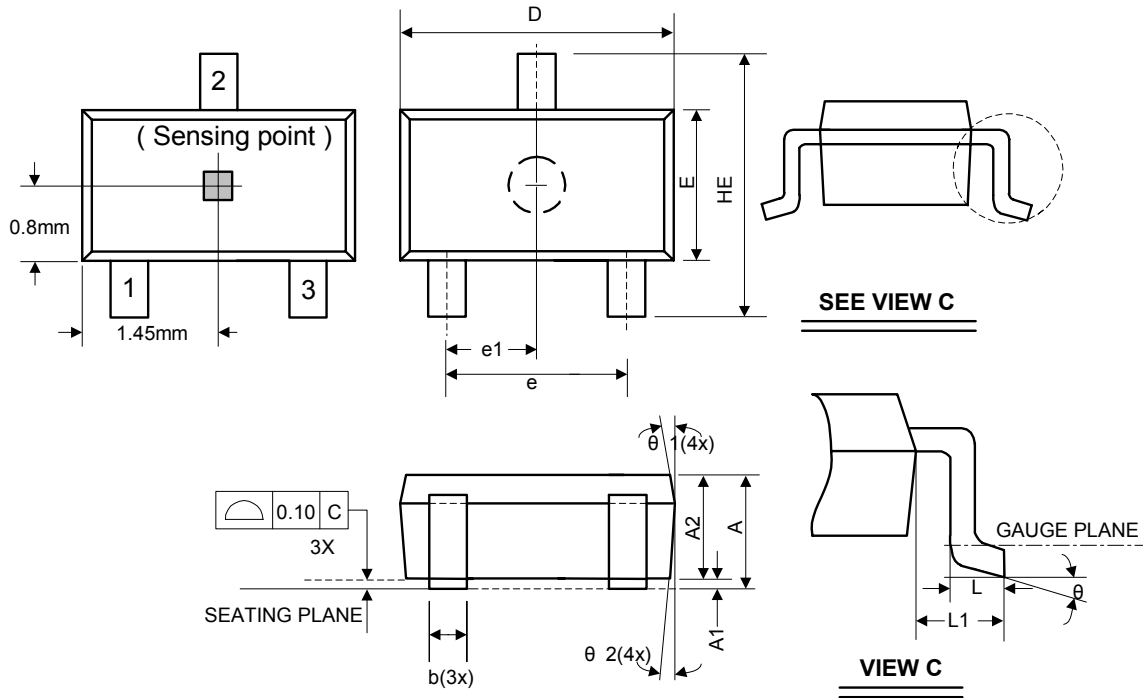

Symbol	Dimensions In Millimeters			Dimensions In Inches		
	Min.	Nom.	Max.	Min.	Nom.	Max.
A	1.05	-	1.35	0.041	-	0.053
A1	0.05	-	0.15	0.002	-	0.006
A2	1.00	1.10	1.20	0.039	0.043	0.047
b	0.25	-	0.50	0.010	-	0.020
C	0.08	-	0.20	0.003	-	0.008
D	2.70	2.90	3.00	0.106	0.114	0.118
E	1.50	1.60	1.70	0.059	0.063	0.067
HE	2.60	2.80	3.00	0.102	0.110	0.118
L	0.30	-	0.55	0.012	-	0.022
L1	0.50	0.60	0.70	0.020	0.024	0.028
e	1.80	1.90	2.00	0.071	0.075	0.079
e1	0.85	0.95	1.05	0.033	0.037	0.041
θ	0°	5°	10°	0°	5°	10°
θ_1	3°	5°	7°	3°	5°	7°
θ_2	6°	8°	10°	6°	8°	10°