

## Key Features

- 2 channel quadrature TTL squarewave outputs (A/B) with 16 pulses per revolution
- Rotary direction information available
- Optional 3<sup>rd</sup> channel index (one pulse per revolution) which is user programmable. This allows cost effective manufacturing of the encoder system.
- Rotation speed of magnetic source up to 30,000 rpm
- Extended temperature range: - 40°C to +125°C (-40°F to +257°F)
- System on Chip: Hall effect sensors and signal processing combined on a single chip
- Simple permanent magnetic source required

## Benefits

- Non-contact switching providing high reliability and long mechanical life time. Ideal for electrically isolated applications.
- Extremely compact SOIC-8 package
- Ease of implementation with reduced number of external components
- No calibration needed
- Extremely tolerant to magnetic and harsh environment
- Tolerant to magnetic source misalignment

## Applications

- Motor control
- Incremental encoders
- Precision angular position sensing
- Angular Speed Sensing
- Motion control

## General Description

The AS5021 device provides a 2 x 16 pulse quad A/B signal within one rotation, encoding 64 state changes. These incremental steps are encoded by a simple magnet source that is placed above the device surface. A total of 64 incremental angular positions are available within the full 360° range (typical step size: 5.625°).



Figure 1 Placement of AS5021 device and magnet source

The optional 3<sup>rd</sup> channel index (one pulse per revolution) is user programmable and allows one time programming of a user specific index-position between the device and the magnet source.

The device includes a Hall sensor array as well as the signal conditioning and the post processing circuits. Figure 2 shows the working principal of the AS5021 device.

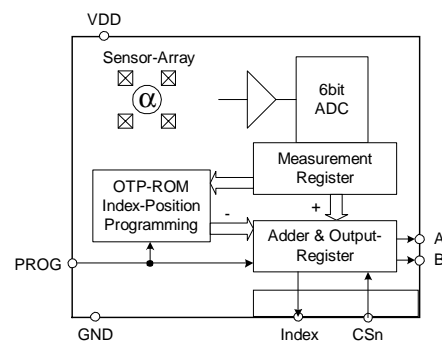
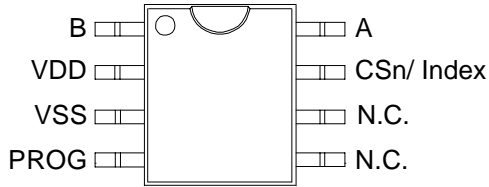

Figure 2 Block diagram

## Pin Configuration



## Pin Description

Pin #	Symbol	Type	Description
1	B	DO	This pin represents signal B of quad A/B outputs. Signal B changes the state every 11.25° and is shifted 5.625° relative to signal A.
2	V <sub>DD</sub>	AI	Positive Supply Voltage.
3	V <sub>SS</sub>	AI	Negative Supply Voltage (GND).
4	PROG	DI	<b>PRO</b> gramming Input This pin is used to program the index position into a non-volatile memory (One Time Programmable).
5	N.C.	AI	Not Connected during operation. This pin is for manufacturers use only
6	N.C.	AI	Not Connected during operation. This pin is for manufacturer's use only.
7	CSn/ Index	DIO	Chip Select (active low) CSn=0 activates the device and enables measurement. <b>Index</b> After programming an user specific index position this pin provides one index pulse per revolution. A version with pre-programmed index can be delivered.
8	A	DO	This pin represents signal A of quad A/B outputs. Signal A changes the state every 11.25° and is shifted 5.625° relative to signal B.

DI: Digital Input  
 AI: Analogue Input  
 DO: Digital Output  
 DIO: Digital Input Output

Note: Pins 4, 5 and 6 may be either left open or connected together

## Functional Description

A Hall sensor array is used to convert the magnetic field distributed above the chip surface into a quadrature output signal. Any angular change of 5.625° results in a change in state of either A or B output.

Figure 3 shows the changing of the quad A/B signal in clockwise (CW) and counter-clockwise (CCW) direction.

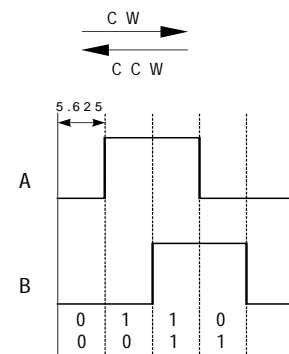

Figure 3 Quadrature A/B signal

Figure 4 shows the output signals A and B for one full 360° rotation. 16 pulses per revolution, each interpolating 4 position changes, lead to a resolution of 64 increments over 360° with a maximum output frequency of 8,000 Hz.

Chip Select must be active low (CSn=0) to enable measurement and to activate the output pin A and B (pin 8 and 1).

Pin A and pin B change the state every 11.25°. The 90 degree phase shift between channel A and B indicates the direction of the magnet's movement. Channel A leads channel B by 5.625 degree for a clockwise rotation of the rotor viewed from the encoder cover. Channel B leads channel A for a counter clockwise rotation of the rotor.

With Chip Select at logic high, the device returns to the power down state. A and B becomes high ohmic (e.g. for use in bus systems).

The AS5021 is extremely tolerant to magnetic misalignment and to environmental influences due to the design adopted for the ratiometric measurement and Hall sensor conditioning circuitry.

Due to the very high level of system integration, the AS5021 allows for easy implementation of an angular measurement system. Only two external components, a magnetic field source and a de-coupling capacitor, are required.

### Timing Diagrams

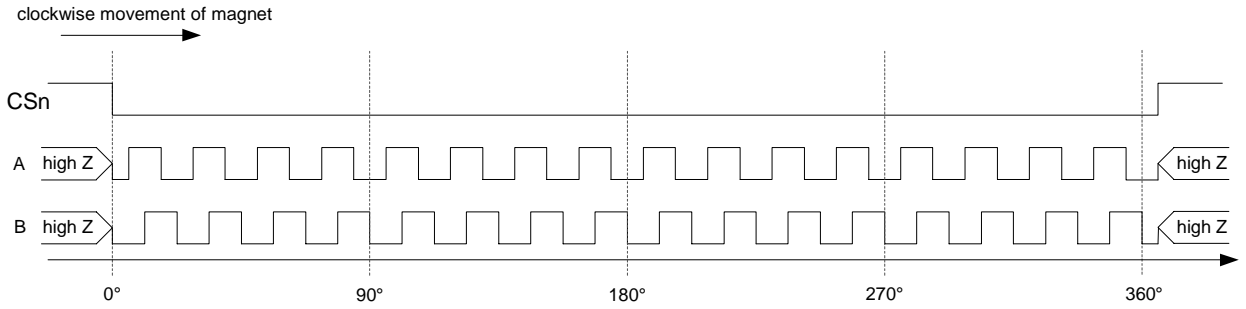

Figure 4 Output signals A and B for one full 360° rotation in standard mode

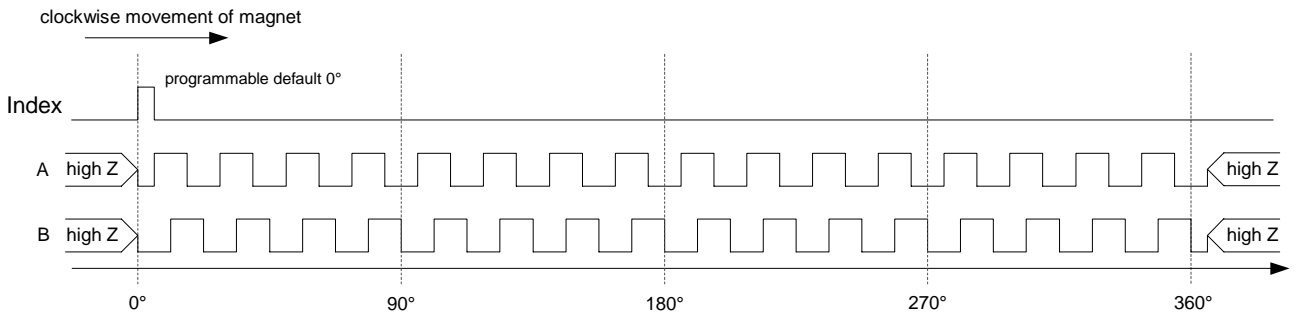

Figure 5 Output signals A, B and index for one full 360° rotation in continuous read out mode

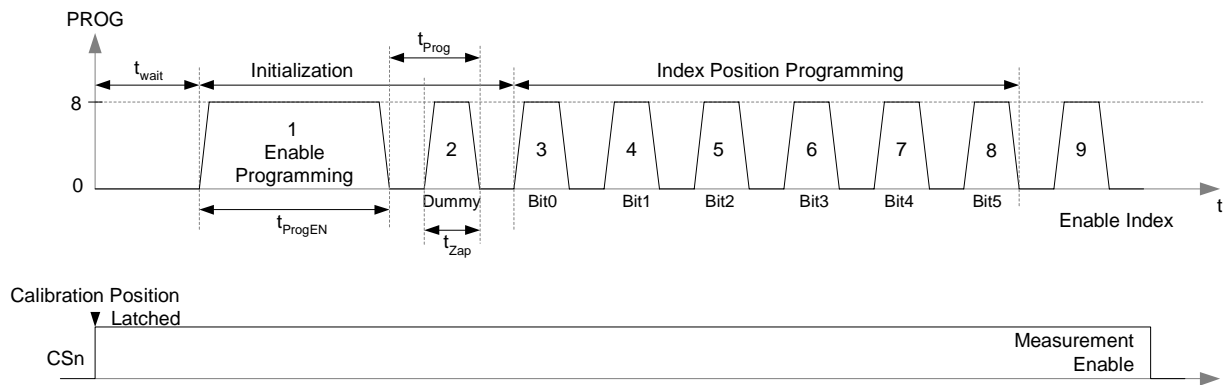

Figure 6 Programming sequence

As illustrated in figure 7, a simple two-pole permanent magnet may be used as the magnetic field source.

The magnet may be a diametrically magnetized, cylindrical standard magnet. Magnetic materials such as rare earth AlNiCo / SmCo5 or NdFeB are recommended. Typically, the magnet size should be 3 to 6mm in diameter and 2 to 3mm in height. The typical distance between the magnet and the device is 0.5 to 1.5 mm.

A magnetic field strength of typically  $\pm 40\text{mT}$  is required at the package surface and a diameter of 1.6 mm.

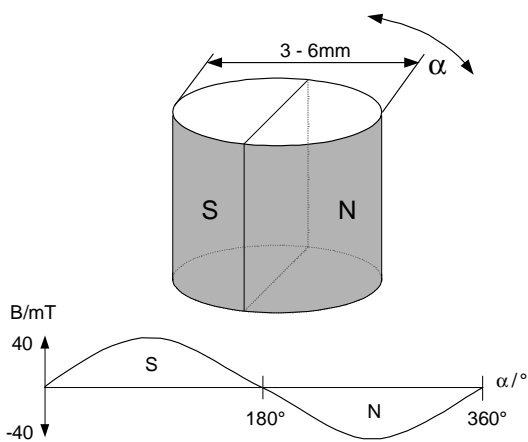

Figure 7 Typical magnet and magnetic field at the diameter of 1.5mm

## Programming of Index Pulse

The possibility to program the optional 3rd channel index pulse at a user specific position gives many advantages (e.g. it simplifies the assembly at the production line, as the orientation of the magnet does not need to be considered).

Figure 6 shows the timing diagram for programming the user specific index pulse (one pulse per revolution). The typical values are shown in the table on page 5.

Before programming the user specific index position the magnet must be adjusted in measurement mode ( $CSn=0$ ).

The rising edge of  $CSn$  measures the actual position between the device and the magnetic source and stores it internally for the permanent programming  $CSn$  must be high during the whole programming sequence.

The first 8V pulse after the minimum waiting time  $t_{wait}$  sets the device into programming mode. It is important that this first

pulse has a minimum duration of  $t_{progEN} = 200 \mu\text{s}$ . The following 7 pulses with  $8\text{V}/5\mu\text{s}$  select the latched position information and permanently write the reference value into the OTP ROM. The 9th pulse enables the index.

The index pulse at pin 7 will be available after switching the power off and on again.

## Physical Placement of the Magnet

The magnet may be placed above or below the device. The distance must be within the specified range and the rotation axis should be aligned to the device center.

The recommended axis point is given by the crossing of the diagonals with respect to the leadframe.

Accurate placement is important to achieve the specified accuracy with respect to the temperature and the voltage ranges. Figure 8 shows the maximum allowed misalignment of the magnet with respect to the device, the typical values are shown in the table on page 6.

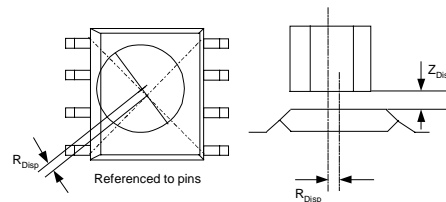

Figure 8 Maximum allowed misalignment of magnet with respect to the device

If placement tolerances are larger than specified, the device continues to operate at a reduced linearity performance.

## Electrical Characteristics

### Absolute Maximum Ratings

Symbol	Parameter	Remarks	Min	Typ	Max	Unit
V <sub>DD</sub>	Max. Supply Voltage		-0.3		7	V
I <sub>LUI</sub>	Max. Input Current	Latch-up immunity / Norm JEDEC 17		25		mA
V <sub>IN</sub>	Max. Digital Input Voltage		-0.3		V <sub>DD</sub> + 0.3	V
ESD	Electrostatic Discharge	Norm MIL883E method 3015	-1000		+1000	V
T <sub>Store</sub>	Storage Temperature Range		-50		+125	°C
P <sub>tot</sub>	Total Power Dissipation				150	mW
H	Humidity non-condensing		5		85	%
	Soldering Conditions	Norm: IEC 6170-1	0.7 V <sub>DD</sub>		V <sub>DD</sub>	V

Stresses beyond those listed under "Absolute Maximum Ratings" may cause permanent damage to the device. These are stress ratings only. Functional operation of the device at these or any other conditions beyond those indicated under "Operating Conditions" is not implied. Exposure to absolute maximum rating conditions for extended periods may affect device reliability.

### Operating Conditions

Symbol	Parameter	Conditions	Min	Typ*	Max	Unit
V <sub>DD</sub>	Supply Voltage	Measurement mode, V <sub>SS</sub> =0V	4.75	5.0	5.25	V
T <sub>AMB</sub>	Ambient Operating Temp. Range		-40		+125	°C
V <sub>IL</sub>	Input Low Voltage		V <sub>SS</sub>		0.3 V <sub>DD</sub>	V
V <sub>IH</sub>	Input High Voltage**		0.7 V <sub>DD</sub>		V <sub>DD</sub>	V

Note: External Buffer Capacitance is needed: e.g. 4.7µF between the supply pins

\* typical figures at 25°C are for design aid only; not guaranteed and not subjected to production testing.

\*\* At pin PROG a higher voltage (up to 8.5V) is defined for the zero position programming routine.

### DC Characteristics

Symbol	Parameter	Conditions	Min	Typ	Max	Unit
I <sub>DD</sub>	Operating Supply Current	CSn=0, Continuous Mode	15		24	mA
I <sub>o</sub>	Digital Output Current Capability				4	mA

### Programming Input (see Figure 6)

Symbol	Parameter	Conditions	Min	Typ*	Max	Unit
V <sub>PROG</sub>	Programming Voltage	Measurement mode, V <sub>SS</sub> =0V	8		8.5	V
t <sub>Zap</sub>	Zap Pulse Duration		4.5	5	5.5	µs
t <sub>Prog</sub>	Programming Period		9	10	11	µs
t <sub>Wait</sub>	Minimum Waiting Time after Rising Edge of CSn		0.5			µs
t <sub>ProgEN</sub>	Delay after CSn=1		200			µs
T <sub>LH</sub>	Pulse Slew Rate		2			V/µs
I <sub>PROG</sub>	Programming Current				100	mA

## Timing Characteristics

Symbol	Parameter	Conditions	Min	Typ*	Max	Unit
$t_{\text{setup}}$	Setup Time after Power-on		20			$\mu\text{s}$

## Magnetic Input Characteristics

Recommended: cylindrical two pole source diametrically magnetized,  $\varnothing 3$  to 6mm, h=2mm

Symbol	Parameter	Conditions	Min	Typ	Max	Unit
$B_{\text{min-max}}$	Magnetic Field Strength Input Range	At chip surface (package surface is 0.5mm above chip) Sinusoidal magnetic field density along concentric circle with 1.6mm diameter.	30	40	50	mT
$\text{Off}_{\text{mag}}$	Magnetic Offset	e.g. overlapping, external stray field	-5		5	mT
$\text{DistF}_{\text{mag}}$	Magnetic Distortion Factor (magnetic field non-linearity)			2	3	%
$T_d$	Magnet Temperature Drift			-0.035		%/K
D	Diameter of Encoder Magnet		3	6		mm
f	Input Frequency	Both directions			30,000	rpm

\*Note: Please ask for our preferred Magnet Supplier List.

## System Performance

Symbol	Parameter	Conditions	Min	Typ	Max	Unit
PPR	Pulses per Revolution			2 * 16		lines/rev
INC	Incremental Step Size			5.625		deg
$\text{INL}_{\text{opt}}$	Optimum Integral Non-Linearity	See Note 2) $T=25^\circ$ , optimum alignment using recommended magnetic source			+/-1.00	deg
INL	Integral Non-Linearity	See Note 2) $-40 < T < 125^\circ$ , with specified tolerances			+/-2.813	deg
DNL	Differential Non-Linearity	See Note 2) No missing codes guaranteed			+/-2.813	deg
TN	Transition Noise			0.5		deg

1. Linearity is defined in terms of end point fit and guaranteed by design, proved by simulated test signals
2. System linearity limited by magnetic source linearity
3. Box method is used to calculate parameter drift over temperature

## Magnet Placement \*

Symbol	Parameter	Conditions	Min	Typ	Max	Unit
$R_{\text{Disp}}$	Displacement radius of rotational axis with reference to pins	Magnet centered on rotational axis	-0.25		+0.25	mm
$Z_{\text{Dist}}$	Distance between permanent magnet and package surface	With reference magnet (depends on magnet used)		1		mm

\*Note: These values depend strongly on the magnet

## Mechanical Dimensions

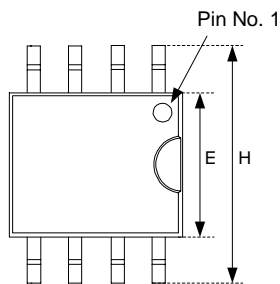
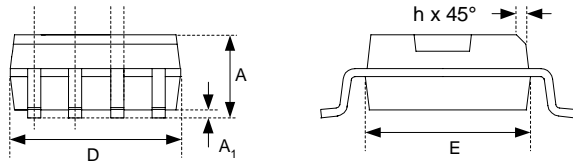

	Common Dimensions (in mm)		
	min.	nom.	max.
A	1,55	1,63	1,73
A <sub>1</sub>	0,127	0,15	0,25
D	4,80	4,93	4,98
E	3,81	3,94	3,99
H	5,84	5,99	6,20

## Available Documents

Magnet Supplier List

Application Notes:

- Contactless position and speed measurement of the rotor in electric motors
- Magnetic properties required for use with the AS5020/AS5021

## Ordering Information

AS5021-E Incremental angular encoder

Package: SOIC-8 Narrow Body

Delivery: Tape and Reel (1 reel = 2500 devices)

Tubes (1 box = 100 tubes á 97 devices)

Order # 2670-001 for delivery in tubes

Order # 2670-201 for delivery in tape and reel

## Copyright

Devices sold by austriamicrosystems are covered by the warranty and patent indemnification provisions appearing in its Term of Sale. austriamicrosystems makes no warranty, express, statutory, implied, or by description regarding the information set forth herein or regarding the freedom of the described devices from patent infringement. austriamicrosystems reserves the right to change specifications and prices at any time and without notice. Therefore, prior to designing this product into a system, it is necessary to check with austriamicrosystems for current information. This product is intended for use in normal commercial applications.

Copyright © 2001 austriamicrosystems. Trademarks registered ®. All rights reserved. The material herein may not be reproduced, adapted, merged, translated, stored, or used without the prior written consent of the copyright owner. To the best of its knowledge, austriamicrosystems asserts that the information contained in this publication is accurate and correct. However, austriamicrosystems shall not be liable to recipient or any third party for any damages, including but not limited to personal injury, property damage, loss of profits, loss of use, interruption of business or indirect, special, incidental or consequential damages, of any kind, in connection with or arising out of the furnishing, performance or use of the technical data herein. No obligation or liability to recipient or any third party shall arise or flow out of austriamicrosystems rendering of technical or other services.

## Contact

### Headquarters

austriamicrosystems AG  
A 8141 Schloss Premstätten, **Austria**  
Phone: +43 3136 500 0  
Fax: +43 3136 525 01  
[industry.medical@austriamicrosystems.com](mailto:industry.medical@austriamicrosystems.com)  
[www.austriamicrosystems.com](http://www.austriamicrosystems.com)

### Sales Offices

austriamicrosystems Germany GmbH  
Tegernseer Landstrasse 85  
D-81539 München, **Germany**  
Phone: +49 89 69 36 43 0  
Fax: +49 89 69 36 43 66

austriamicrosystems France S.A.R.L.  
124, Avenue de Paris  
F-94300 Vincennes, **France**  
Phone: +33 1 43 74 00 90  
Fax: +33 1 43 74 20 98

austriamicrosystems UK, Ltd.  
Coliseum Business Centre  
Watchmoor Park  
Camberley, Surrey  
England GU15 3YL, **United Kingdom**  
Phone: +44 1276 23 3 99  
Fax: +44 1276 29 3 53

austriamicrosystems Switzerland AG  
Rietstrasse 4  
CH-8640 Rapperswil, **Switzerland**  
Phone: +41 55 220 9008  
Fax: +41 55 220 9001

austriamicrosystems USA, Inc.  
8601 Six Forks Road  
Suite 400  
Raleigh, NC 27615, **USA**  
Phone: +1 919 676 5292  
Fax: +1 509 696 2713

austriamicrosystems AG  
Suite 811, Tsimshatsui Centre  
East Wing, 66 Mody Road  
Tsim Sha Tsui East, Kowloon, **Hong Kong**  
Phone: +852 2268 6899  
Fax: +852 2268 6799

austriamicrosystems AG  
Shin Yokohama Daini, Center Bldg. 10F  
3-19-5, Shin Yokohama  
Kohoku-ku, Yokohama 222-0033, **Japan**  
Phone: +81 45 474 0962  
Fax: +81 45 472 9845

austriamicrosystems AG  
Singapore Representative Office  
83 Clemenceau Avenue, #02-01 UE Square  
239920, **Singapore**  
Phone: +65 68 30 83 05