



FASTcard™ 2

FDDI PC/AT-Based SUPERNET® 2 Technology Card (FASTcard) Dual Attachment Concentrator Board Set and Software Package

DISTINCTIVE CHARACTERISTICS

- IBM PC-AT or compatible plug-in board to implement an FDDI station
- Highly integrated: single board DAS, four master ports per MP board
- AMD's FORMAC Plus (Am79C830A) and AmPHY (Am79C864, Am79865 and Am79866) second generation FDDI devices
- 128K byte SRAM buffer memory with parity
- Extensive implementation of station management (SMT) services in silicon (including physical connection management (PCM), station insertion and removal, station configuration management and fault detection, isolation and recovery, and duplicate address detection)
- Protocol independent—operates with all standard protocols and network operating systems
- Built-in interface for external address matching logic (e.g. CAM)
- LED status indicators for ring operational and for port A, port B, and master ports physical connection
- Station management (SMT) software and device drivers for on-board resources
- Software support package
 - pDEMO 2 (demonstration software)

GENERAL DESCRIPTION

The FASTcard 2 is a PC/AT-based, single MAC, dual attachment FDDI concentrator board-set, based on AMD's second generation SUPERNET 2 FDDI devices. The board set consists of two board types: a dual attachment station (DAS) board, and a master ports (MP) board. The basic 2-board set configures a 4-station dual attachment concentrator. By adding additional MP boards, 8-station or 12-station dual attachment concentrators can be configured.

The FASTcard 2 evaluation board uses AMD's proven SUPERNET 2 hardware solution to operate as an FDDI compliant node. The kit can be used as a model design to base new FDDI development on or it can be used to debug and test your existing system. The hardware and

software have been tested and revised to make them more robust and interoperable with multiple vendors' equipment. In fact, you can use the FASTcard 2 tools to check your own system for interoperability.

The FASTcard 2 provides complete hardware and software tools to implement a FDDI Dual Attachment Station (DAS) or a concentrator. Along with the board, the DAS card comes with pDEMO 2 (a user interface application), user manuals, SUPERNET 2 Data Book, ribbon cable and connectors, and 10 ft fiber optic cables and connectors. The Master Port board(s) may be purchased separately to configure a 4, 8 or 12 station dual attachment concentrator.

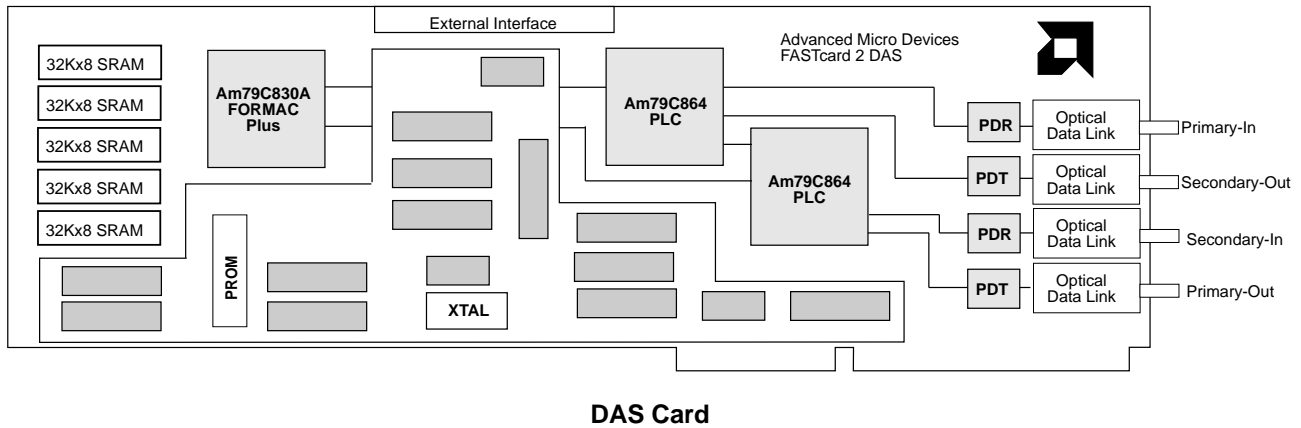

DAS Card

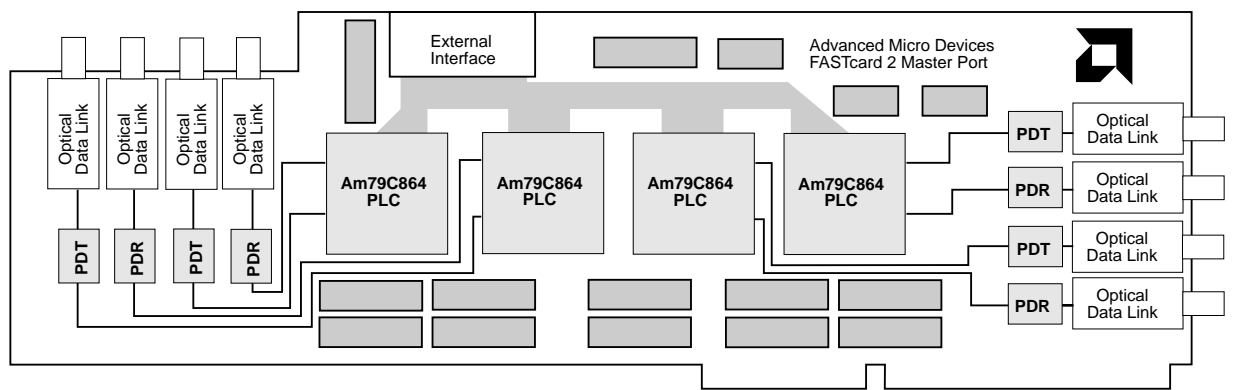

MP Card

16047B-1

HARDWARE

The FASTcard 2 hardware consists of two main sections; the FDDI station logic and the associated interface logic. The FDDI station logic consists of the SUPERNET 2 chip set, the buffer memory, and the fiber optic transmitter/receiver. The chip set performs the buffer memory management tasks in addition to the MAC and PHY layer functions. The buffer memory on the FASTcard 2 hardware consists of 128K bytes organized as 32K x 36 bits. Buffer memory control logic provides the host CPU with direct access to the FDDI buffer memory via the host DMA interface of the FORMAC Plus (Am79C830A).

The interface logic consists of the AT bus interface, the host-buffer memory interface, counter and interrupt logic, Connection Management (CMT) logic, and FDDI configuration hooks and control logic. The CMT logic is responsible for gathering connection statistics of the network to report them to the station. The DAS board provides interface signals to additional MP cards when constructing a concentrator. The DAS board makes use of the AT's processor as the host and node controller.

ORDERING INFORMATION

Ordering Part Number (OPN)	Description
AmFDDI-PC-DAS	Dual Attachment Station (DAS) Board
AmFDDI-PC-MP	4-Port Master Port (MP) Board
AmFDDI-PC-CON	Concentrator Board Set (1-DAS, 1-MP)

For more information, please contact your local AMD sales office.