



# Am29DL322D/323D/324D

32 Megabit (4 M x 8-Bit/2 M x 16-Bit)

CMOS 3.0 Volt-only, Simultaneous Operation Flash Memory

## DISTINCTIVE CHARACTERISTICS

### ARCHITECTURAL ADVANTAGES

- **Simultaneous Read/Write operations**
  - Data can be continuously read from one bank while executing erase/program functions in other bank.
  - Zero latency between read and write operations
- **Multiple bank architectures**
  - Three devices available with different bank sizes (refer to Table 3)
- **SecSi™ (Secured Silicon) Sector**
  - Current version of device has 64 Kbytes; future versions will have 256 bytes
  - *Factory locked and identifiable*: 16 bytes available for secure, random factory Electronic Serial Number; verifiable as factory locked through autoselect function. ExpressFlash option allows entire sector to be available for factory-secured data
  - *Customer lockable*: Can be read, programmed, or erased just like other sectors. Once locked, data cannot be changed
- **Zero Power Operation**
  - Sophisticated power management circuits reduce power consumed during inactive periods to nearly zero.
- **Package options**
  - 63-ball FBGA
  - 48-pin TSOP
- **Top or bottom boot block**
- **Manufactured on 0.23 μm process technology**
- **Compatible with JEDEC standards**
  - Pinout and software compatible with single-power-supply flash standard

### PERFORMANCE CHARACTERISTICS

- **High performance**
  - Access time as fast 70 ns
  - Program time: 7 μs/word typical utilizing Accelerate function
- **Ultra low power consumption (typical values)**
  - 2 mA active read current at 1 MHz
  - 10 mA active read current at 5 MHz
  - 200 nA in standby or automatic sleep mode

- **Minimum 1 million write cycles guaranteed per sector**
- **20 year data retention at 125°C**
  - Reliable operation for the life of the system

### SOFTWARE FEATURES

- **Data Management Software (DMS)**
  - AMD-supplied software manages data programming, enabling EEPROM emulation
  - Eases historical sector erase flash limitations
- **Supports Common Flash Memory Interface (CFI)**
- **Erase Suspend/Erase Resume**
  - Suspends erase operations to allow programming in same bank
- **Data# Polling and Toggle Bits**
  - Provides a software method of detecting the status of program or erase cycles
- **Unlock Bypass Program command**
  - Reduces overall programming time when issuing multiple program command sequences

### HARDWARE FEATURES

- **Any combination of sectors can be erased**
- **Ready/Busy# output (RY/BY#)**
  - Hardware method for detecting program or erase cycle completion
- **Hardware reset pin (RESET#)**
  - Hardware method of resetting the internal state machine to the read mode
- **WP#/ACC input pin**
  - Write protect (WP#) function allows protection of two outermost boot sectors, regardless of sector protect status
  - Acceleration (ACC) function accelerates program timing
- **Sector protection**
  - Hardware method of locking a sector, either in-system or using programming equipment, to prevent any program or erase operation within that sector
  - Temporary Sector Unprotect allows changing data in protected sectors in-system

## GENERAL DESCRIPTION

The Am29DL322D/323D/324D family consists of 32 megabit, 3.0 volt-only flash memory devices, organized as 2,097,152 words of 16 bits each or 4,194,304 bytes of 8 bits each. Word mode data appears on DQ0–DQ15; byte mode data appears on DQ0–DQ7. The device is designed to be programmed in-system with the standard 3.0 volt  $V_{CC}$  supply, and can also be programmed in standard EPROM programmers.

The devices are available with an access time of 70, 90 or 120 ns. The devices are offered in 48-pin TSOP and 63-ball FBGA packages. Standard control pins—chip enable (CE#), write enable (WE#), and output enable (OE#)—control normal read and write operations, and avoid bus contention issues.

The devices requires only a **single 3.0 volt power supply** for both read and write functions. Internally generated and regulated voltages are provided for the program and erase operations.

### Simultaneous Read/Write Operations with Zero Latency

The Simultaneous Read/Write architecture provides **simultaneous operation** by dividing the memory space into two banks. The device can improve overall system performance by allowing a host system to program or erase in one bank, then immediately and simultaneously read from the other bank, with zero latency. This releases the system from waiting for the completion of program or erase operations.

The Am29DL32xD device family uses multiple bank architectures to provide flexibility for different applications. Two devices are available with the following bank sizes:

Device	Bank 1	Bank 2
DL322	4	28
DL323	8	24
DL324	16	16

### Am29DL322D/323D/324D Features

The **SecSi™ (Secured Silicon) Sector** is an extra sector capable of being permanently locked by AMD or customers. The **SecSi Indicator Bit** (DQ7) is permanently set to a 1 if the part is **factory locked**, and set to a 0 if **customer lockable**. This way, customer lockable parts can never be used to replace a factory locked part. **Current version of device has 64 Kbytes; future versions will have only 256 bytes. This should be considered during system design.**

Factory locked parts provide several options. The SecSi Sector may store a secure, random 16 byte ESN (Electronic Serial Number), customer code (programmed through AMD's ExpressFlash service), or both. Customer Lockable parts may utilize the SecSi

Sector as bonus space, reading and writing like any other flash sector, or may permanently lock their own code there.

**DMS (Data Management Software)** allows systems to easily take advantage of the advanced architecture of the simultaneous read/write product line by allowing removal of EEPROM devices. DMS will also allow the system software to be simplified, as it will perform all functions necessary to modify data in file structures, as opposed to single-byte modifications. To write or update a particular piece of data (a phone number or configuration data, for example), the user only needs to state which piece of data is to be updated, and where the updated data is located in the system. This is an advantage compared to systems where user-written software must keep track of the old data location, status, logical to physical translation of the data onto the Flash memory device (or memory devices), and more. Using DMS, user-written software does not need to interface with the Flash memory directly. Instead, the user's software accesses the Flash memory by calling one of only six functions. AMD provides this software to simplify system design and software integration efforts.

The device offers complete compatibility with the **JEDEC single-power-supply Flash command set standard**. Commands are written to the command register using standard microprocessor write timings. Reading data out of the device is similar to reading from other Flash or EPROM devices.

The host system can detect whether a program or erase operation is complete by using the device **status bits**: RY/BY# pin, DQ7 (Data# Polling) and DQ6/DQ2 (toggle bits). After a program or erase cycle has been completed, the device automatically returns to the read mode.

The **sector erase architecture** allows memory sectors to be erased and reprogrammed without affecting the data contents of other sectors. The device is fully erased when shipped from the factory.

**Hardware data protection** measures include a low  $V_{CC}$  detector that automatically inhibits write operations during power transitions. The **hardware sector protection** feature disables both program and erase operations in any combination of the sectors of memory. This can be achieved in-system or via programming equipment.

The device offers two power-saving features. When addresses have been stable for a specified amount of time, the device enters the **automatic sleep mode**. The system can also place the device into the **standby mode**. Power consumption is greatly reduced in both modes.

## TABLE OF CONTENTS

<b>Product Selector Guide</b> .....	<b>4</b>	DQ6: Toggle Bit I .....	29
<b>Block Diagram</b> .....	<b>4</b>	Figure 6. Toggle Bit Algorithm .....	29
<b>Connection Diagrams</b> .....	<b>5</b>	DQ2: Toggle Bit II .....	30
Special Handling Instructions for FBGA Package .....	6	Reading Toggle Bits DQ6/DQ2 .....	30
<b>Pin Description</b> .....	<b>6</b>	DQ5: Exceeded Timing Limits .....	30
<b>Logic Symbol</b> .....	<b>6</b>	DQ3: Sector Erase Timer .....	30
<b>Ordering Information</b> .....	<b>7</b>	<b>Absolute Maximum Ratings</b> .....	<b>32</b>
<b>Device Bus Operations</b> .....	<b>8</b>	Figure 7. Maximum Negative Overshoot Waveform .....	32
Word/Byte Configuration .....	8	Figure 8. Maximum Positive Overshoot Waveform .....	32
Requirements for Reading Array Data .....	8	<b>DC Characteristics</b> .....	<b>33</b>
Writing Commands/Command Sequences .....	9	Figure 9. $I_{CC1}$ Current vs. Time (Showing Active and	
Simultaneous Read/Write Operations		Automatic Sleep Currents).....	34
with Zero Latency .....	9	Figure 10. Typical $I_{CC1}$ vs. Frequency.....	34
Standby Mode .....	9	<b>Test Conditions</b> .....	<b>35</b>
Automatic Sleep Mode .....	9	Figure 11. Test Setup .....	35
RESET#: Hardware Reset Pin .....	10	Figure 12. Input Waveforms and Measurement Levels .....	35
Output Disable Mode .....	10	<b>AC Characteristics</b> .....	<b>36</b>
Autoselect Mode .....	15	Figure 13. Read Operation Timings.....	36
Sector/Sector Block Protection and Unprotection .....	16	Figure 14. Reset Timings.....	37
Write Protect (WP#) .....	17	Word/Byte Configuration (BYTE#) .....	38
Temporary Sector Unprotect .....	17	Figure 15. BYTE# Timings for Read Operations .....	38
Figure 1. Temporary Sector Unprotect Operation .....	17	Figure 16. BYTE# Timings for Write Operations .....	38
Figure 2. In-System Sector Protection/		<b>Erase and Program Operations</b> .....	<b>39</b>
Sector Unprotection Algorithms .....	18	Figure 17. Program Operation Timings .....	40
SecSi™ (Secured Silicon) Sector		Figure 18. Accelerated Program Timing Diagram .....	40
Flash Memory Region .....	19	Figure 19. Chip/Sector Erase Operation Timings .....	41
Hardware Data Protection .....	20	Figure 20. Back-to-back Read/Write Cycle Timings .....	42
<b>Common Flash Memory Interface (CFI)</b> .....	<b>20</b>	Figure 21. Data# Polling Timings (During Embedded Algorithms) .....	42
<b>Command Definitions</b> .....	<b>22</b>	Figure 22. Toggle Bit Timings (During Embedded Algorithms) .....	43
Reading Array Data .....	22	Figure 23. DQ2 vs. DQ6 .....	43
Reset Command .....	23	Temporary Sector Unprotect .....	44
Autoselect Command Sequence .....	23	Figure 24. Temporary Sector Unprotect Timing Diagram .....	44
Enter SecSi™ Sector/Exit SecSi Sector		Figure 25. Sector/Sector Block Protect and Unprotect Timing Diagram .....	45
Command Sequence .....	23	Alternate CE# Controlled Erase and Program Operations .....	46
Byte/Word Program Command Sequence .....	23	Figure 26. Alternate CE# Controlled Write (Erase/Program)	
Figure 3. Program Operation .....	24	Operation Timings .....	47
Chip Erase Command Sequence .....	24	<b>Erase And Programming Performance</b> .....	<b>48</b>
Sector Erase Command Sequence .....	25	<b>Latchup Characteristics</b> .....	<b>48</b>
Erase Suspend/Erase Resume Commands .....	25	<b>TSOP And SO Pin Capacitance</b> .....	<b>48</b>
Figure 4. Erase Operation .....	26	<b>Data Retention</b> .....	<b>48</b>
<b>Write Operation Status</b> .....	<b>28</b>	<b>Physical Dimensions</b> .....	<b>49</b>
DQ7: Data# Polling .....	28	FBD063—63-ball Fine-Pitch Ball Grid Array (FBGA) 8 x 14 mm .....	49
Figure 5. Data# Polling Algorithm .....	28	TS 048—48-Pin Standard TSOP .....	50
RY/BY#: Ready/Busy# .....	29	<b>Revision Summary</b> .....	<b>51</b>

## PRODUCT SELECTOR GUIDE

Part Number		Am29DL322D/323D/324D		
Speed Option	Regulated Voltage Range: $V_{CC} = 3.0\text{--}3.6\text{ V}$	70R		
	Standard Voltage Range: $V_{CC} = 2.7\text{--}3.6\text{ V}$		90	120
Max Access Time (ns)		70	90	120
CE# Access (ns)		70	90	120
OE# Access (ns)		30	40	50

## BLOCK DIAGRAM

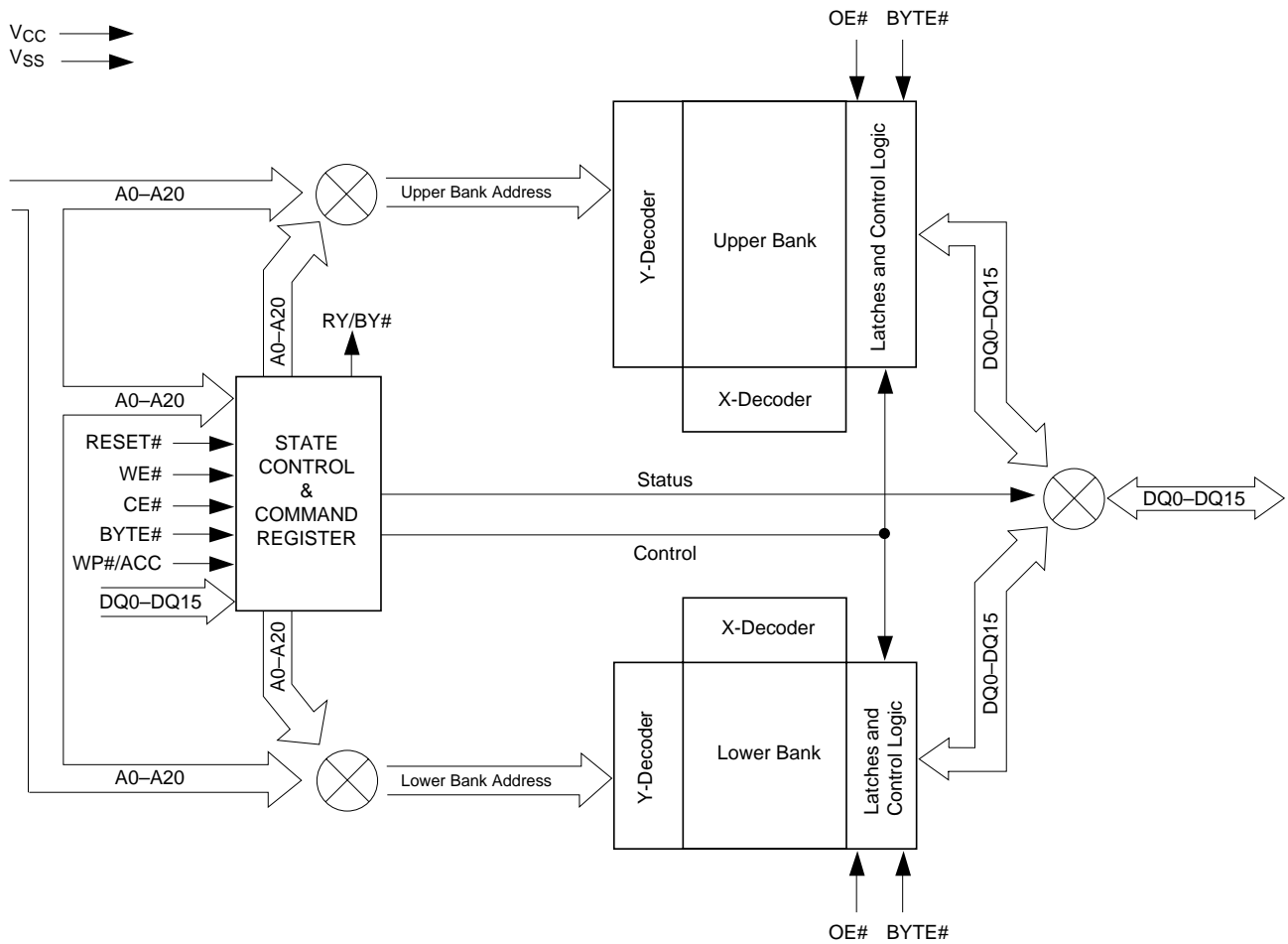

CONNECTION DIAGRAMS

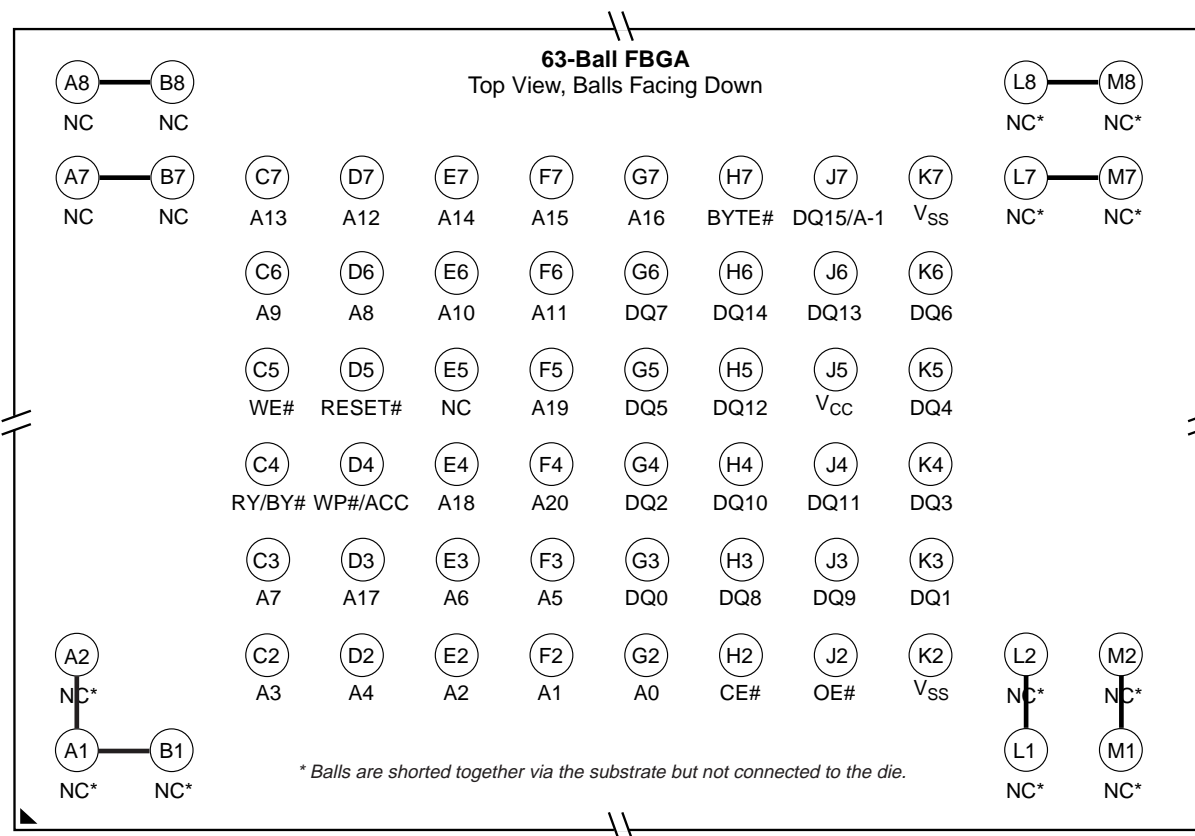
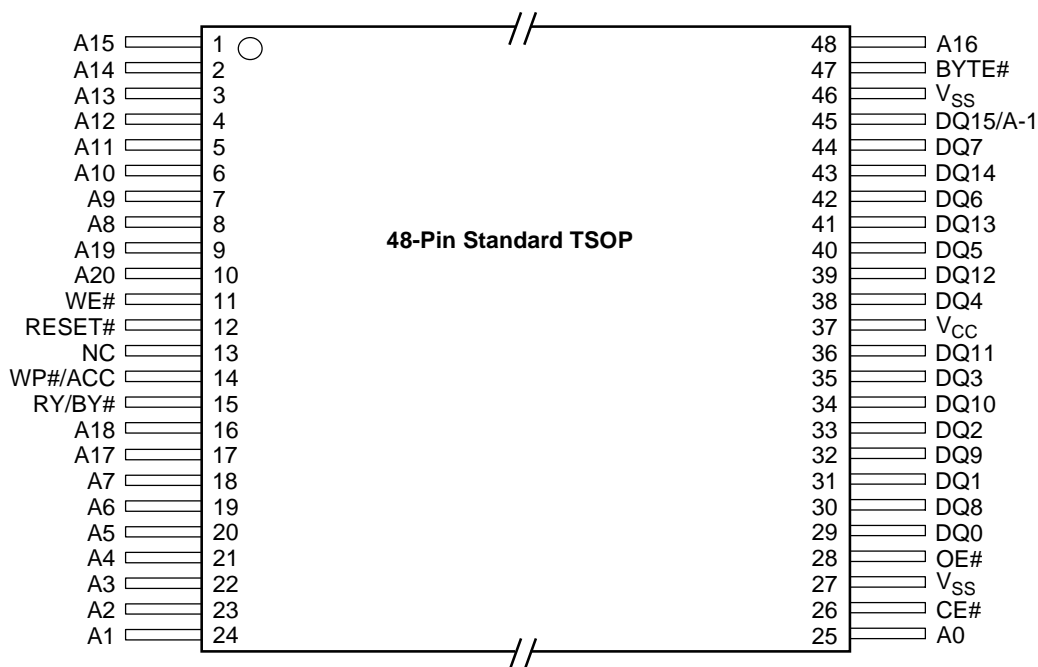

## Special Handling Instructions for FBGA Package

Special handling is required for Flash Memory products in FBGA packages.

Flash memory devices in FBGA packages may be damaged if exposed to ultrasonic cleaning methods. The package and/or data integrity may be compromised if the package body is exposed to temperatures above 150°C for prolonged periods of time.

### PIN DESCRIPTION

A0–A20	= 21 Addresses
DQ0–DQ14	= 15 Data Inputs/Outputs
DQ15/A-1	= DQ15 (Data Input/Output, word mode), A-1 (LSB Address Input, byte mode)
CE#	= Chip Enable
OE#	= Output Enable
WE#	= Write Enable
WP#/ACC	= Hardware Write Protect/ Acceleration Pin
RESET#	= Hardware Reset Pin, Active Low
BYTE#	= Selects 8-bit or 16-bit mode
RY/BY#	= Ready/Busy Output
V <sub>CC</sub>	= 3.0 volt-only single power supply (see Product Selector Guide for speed options and voltage supply tolerances)
V <sub>SS</sub>	= Device Ground
NC	= Pin Not Connected Internally

### LOGIC SYMBOL

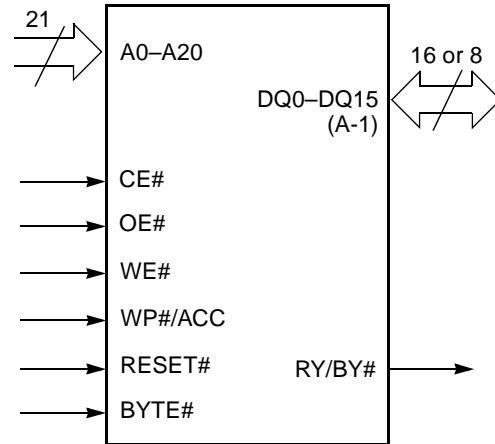

## ORDERING INFORMATION

### Standard Products

AMD standard products are available in several packages and operating ranges. The order number (Valid Combination) is formed by a combination of the following:

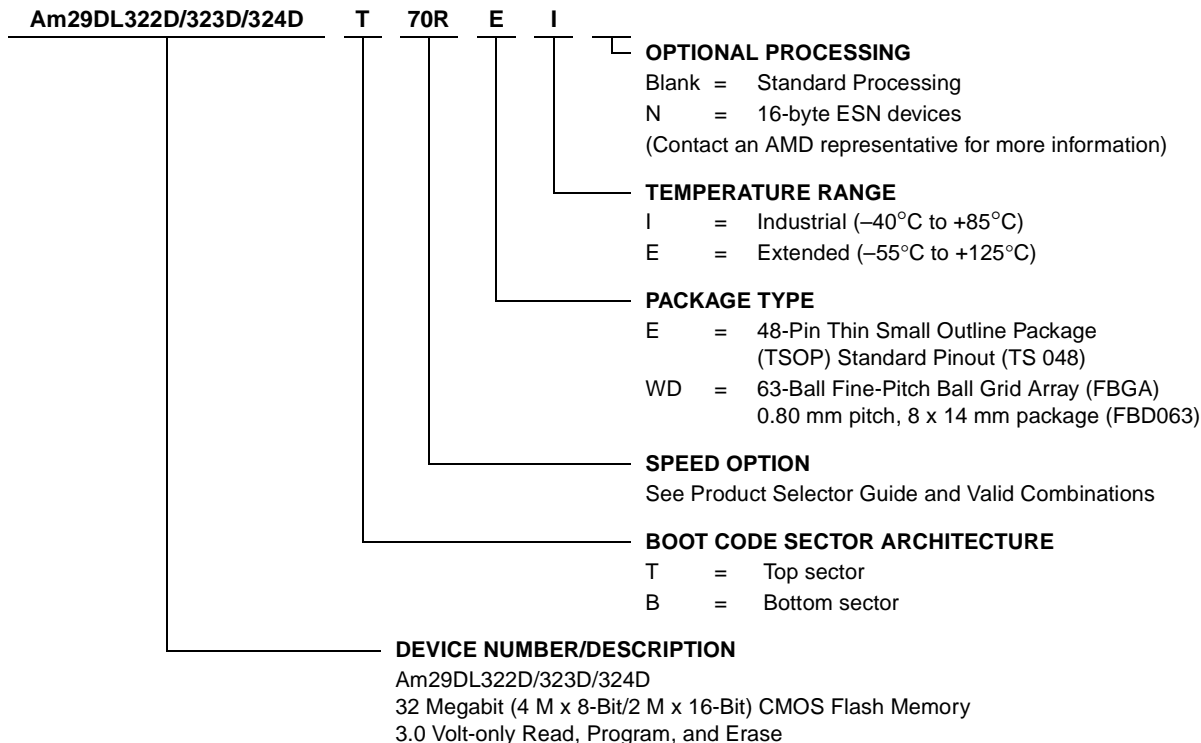

Valid Combinations for TSOP Packages	
AM29DL322DT70R, AM29DL322DB70R	EI, EIN
AM29DL323DT70R, AM29DL323DB70R	
AM29DL324DT70R, AM29DL324DB70R	
AM29DL322DT90, AM29DL322DB90	
AM29DL323DT90, AM29DL323DB90	
AM29DL324DT90, AM29DL324DB90	
AM29DL322DT120, AM29DL322DB120	
AM29DL323DT120, AM29DL323DB120	
AM29DL324DT120, AM29DL324DB120	

#### Valid Combinations

Valid Combinations list configurations planned to be supported in volume for this device. Consult the local AMD sales office to confirm availability of specific valid combinations and to check on newly released combinations.

Valid Combinations for FBGA Packages			
Order Number		Package Marking	
AM29DL322DT70R, AM29DL322DB70R	WDI, WDIN	D322DT70R, D322DB70R	I
AM29DL323DT70R, AM29DL323DB70R		D323DT70R, D323DB70R	
AM29DL324DT70R, AM29DL324DB70R		D324DT70R, D324DB70R	
AM29DL322DT90, AM29DL322DB90		D322DT90V, D322DB90V	
AM29DL323DT90, AM29DL323DB90		D323DT90V, D323DB90V	
AM29DL324DT90, AM29DL324DB90		D324DT90V, D324DB90V	
AM29DL322DT120, AM29DL322DB120		WDI, WDIN, WDE, WDEN	
AM29DL323DT120, AM29DL323DB120	D323DT12V, D323DB12V		
AM29DL324DT120, AM29DL324DB120	D324DT12V, D324DB12V		

## DEVICE BUS OPERATIONS

This section describes the requirements and use of the device bus operations, which are initiated through the internal command register. The command register itself does not occupy any addressable memory location. The register is a latch used to store the commands, along with the address and data information needed to execute the command. The contents of the

register serve as inputs to the internal state machine. The state machine outputs dictate the function of the device. Table 1 lists the device bus operations, the inputs and control levels they require, and the resulting output. The following subsections describe each of these operations in further detail.

**Table 1. Device Bus Operations**

Operation	CE#	OE#	WE#	RESET#	WP#/ACC	Addresses (Note 2)	DQ0– DQ7	DQ8–DQ15	
								BYTE# = V <sub>IH</sub>	BYTE# = V <sub>IL</sub>
Read	L	L	H	H	L/H	A <sub>IN</sub>	D <sub>OUT</sub>	D <sub>OUT</sub>	DQ8–DQ14 = High-Z, DQ15 = A-1
Write	L	H	L	H	(Note 3)	A <sub>IN</sub>	D <sub>IN</sub>	D <sub>IN</sub>	
Standby	V <sub>CC</sub> ± 0.3 V	X	X	V <sub>CC</sub> ± 0.3 V	H	X	High-Z	High-Z	High-Z
Output Disable	L	H	H	H	L/H	X	High-Z	High-Z	High-Z
Reset	X	X	X	L	L/H	X	High-Z	High-Z	High-Z
Sector Protect (Note 2)	L	H	L	V <sub>ID</sub>	L/H	SA, A6 = L, A1 = H, A0 = L	D <sub>IN</sub>	X	X
Sector Unprotect (Note 2)	L	H	L	V <sub>ID</sub>	(Note 3)	SA, A6 = H, A1 = H, A0 = L	D <sub>IN</sub>	X	X
Temporary Sector Unprotect	X	X	X	V <sub>ID</sub>	(Note 3)	A <sub>IN</sub>	D <sub>IN</sub>	D <sub>IN</sub>	High-Z

**Legend:** L = Logic Low = V<sub>IL</sub>, H = Logic High = V<sub>IH</sub>, V<sub>ID</sub> = 8.5–12.5 V, V<sub>HH</sub> = 9.0 ± 0.5 V, X = Don't Care, SA = Sector Address, A<sub>IN</sub> = Address In, D<sub>IN</sub> = Data In, D<sub>OUT</sub> = Data Out

### Notes:

- Addresses are A20:A0 in word mode (BYTE# = V<sub>IH</sub>), A20:A-1 in byte mode (BYTE# = V<sub>IL</sub>).
- The sector protect and sector unprotect functions may also be implemented via programming equipment. See the "Sector/Sector Block Protection and Unprotection" section.
- If WP#/ACC = V<sub>IL</sub>, the two outermost boot sectors remain protected. If WP#/ACC = V<sub>IH</sub>, the two outermost boot sector protection depends on whether they were last protected or unprotected using the method described in "Sector/Sector Block Protection and Unprotection". If WP#/ACC = V<sub>HH</sub>, all sectors will be unprotected.

## Word/Byte Configuration

The BYTE# pin controls whether the device data I/O pins operate in the byte or word configuration. If the BYTE# pin is set at logic '1', the device is in word configuration, DQ0–DQ15 are active and controlled by CE# and OE#.

If the BYTE# pin is set at logic '0', the device is in byte configuration, and only data I/O pins DQ0–DQ7 are active and controlled by CE# and OE#. The data I/O pins DQ8–DQ14 are tri-stated, and the DQ15 pin is used as an input for the LSB (A-1) address function.

## Requirements for Reading Array Data

To read array data from the outputs, the system must drive the CE# and OE# pins to V<sub>IL</sub>. CE# is the power control and selects the device. OE# is the output control and gates array data to the output pins. WE# should remain at V<sub>IH</sub>. The BYTE# pin determines whether the device outputs array data in words or bytes.

The internal state machine is set for reading array data upon device power-up, or after a hardware reset. This ensures that no spurious alteration of the memory content occurs during the power transition. No command is necessary in this mode to obtain array data. Standard microprocessor read cycles that assert valid



addresses on the device address inputs produce valid data on the device data outputs. Each bank remains enabled for read access until the command register contents are altered.

See “Requirements for Reading Array Data” for more information. Refer to the AC Read-Only Operations table for timing specifications and to Figure 13 for the timing diagram.  $I_{CC1}$  in the DC Characteristics table represents the active current specification for reading array data.

## Writing Commands/Command Sequences

To write a command or command sequence (which includes programming data to the device and erasing sectors of memory), the system must drive WE# and CE# to  $V_{IL}$ , and OE# to  $V_{IH}$ .

For program operations, the BYTE# pin determines whether the device accepts program data in bytes or words. Refer to “Word/Byte Configuration” for more information.

The device features an **Unlock Bypass** mode to facilitate faster programming. Once a bank enters the Unlock Bypass mode, only two write cycles are required to program a word or byte, instead of four. The “Word/Byte Configuration” section has details on programming data to the device using both standard and Unlock Bypass command sequences.

An erase operation can erase one sector, multiple sectors, or the entire device. Tables 3–6 indicate the address space that each sector occupies. The device address space is divided into two banks: Bank 1 contains the boot/parameter sectors, and Bank 2 contains the larger, code sectors of uniform size. A “bank address” is the address bits required to uniquely select a bank. Similarly, a “sector address” is the address bits required to uniquely select a sector.

$I_{CC2}$  in the DC Characteristics table represents the active current specification for the write mode. The AC Characteristics section contains timing specification tables and timing diagrams for write operations.

## Accelerated Program Operation

The device offers accelerated program operations through the ACC function. This is one of two functions provided by the WP#/ACC pin. This function is primarily intended to allow faster manufacturing throughput at the factory.

If the system asserts  $V_{HH}$  on this pin, the device automatically enters the aforementioned Unlock Bypass mode, temporarily unprotects any protected sectors, and uses the higher voltage on the pin to reduce the time required for program operations. The system would use a two-cycle program command sequence as required by the Unlock Bypass mode. Removing

$V_{HH}$  from the WP#/ACC pin returns the device to normal operation. Note that the WP#/ACC pin must not be at  $V_{HH}$  for operations other than accelerated programming, or device damage may result. In addition, the WP#/ACC pin must not be left floating or unconnected; inconsistent behavior of the device may result.

## Autoselect Functions

If the system writes the autoselect command sequence, the device enters the autoselect mode. The system can then read autoselect codes from the internal register (which is separate from the memory array) on DQ7–DQ0. Standard read cycle timings apply in this mode. Refer to the Autoselect Mode and Autoselect Command Sequence sections for more information.

## Simultaneous Read/Write Operations with Zero Latency

This device is capable of reading data from one bank of memory while programming or erasing in the other bank of memory. An erase operation may also be suspended to read from or program to another location within the same bank (except the sector being erased). Figure 20 shows how read and write cycles may be initiated for simultaneous operation with zero latency.  $I_{CC6}$  and  $I_{CC7}$  in the DC Characteristics table represent the current specifications for read-while-program and read-while-erase, respectively.

## Standby Mode

When the system is not reading or writing to the device, it can place the device in the standby mode. In this mode, current consumption is greatly reduced, and the outputs are placed in the high impedance state, independent of the OE# input.

The device enters the CMOS standby mode when the CE# and RESET# pins are both held at  $V_{CC} \pm 0.3$  V. (Note that this is a more restricted voltage range than  $V_{IH}$ .) If CE# and RESET# are held at  $V_{IH}$ , but not within  $V_{CC} \pm 0.3$  V, the device will be in the standby mode, but the standby current will be greater. The device requires standard access time ( $t_{CE}$ ) for read access when the device is in either of these standby modes, before it is ready to read data.

If the device is deselected during erasure or programming, the device draws active current until the operation is completed.

$I_{CC3}$  in the DC Characteristics table represents the standby current specification.

## Automatic Sleep Mode

The automatic sleep mode minimizes Flash device energy consumption. The device automatically enables

this mode when addresses remain stable for  $t_{ACC} + 30$  ns. The automatic sleep mode is independent of the CE#, WE#, and OE# control signals. Standard address access timings provide new data when addresses are changed. While in sleep mode, output data is latched and always available to the system.  $I_{CC5}$  in the DC Characteristics table represents the automatic sleep mode current specification.

### RESET#: Hardware Reset Pin

The RESET# pin provides a hardware method of resetting the device to reading array data. When the RESET# pin is driven low for at least a period of  $t_{RP}$ , the device immediately terminates any operation in progress, tristates all output pins, and ignores all read/write commands for the duration of the RESET# pulse. The device also resets the internal state machine to reading array data. The operation that was interrupted should be reinitiated once the device is ready to accept another command sequence, to ensure data integrity.

Current is reduced for the duration of the RESET# pulse. When RESET# is held at  $V_{SS} \pm 0.3$  V, the device draws CMOS standby current ( $I_{CC4}$ ). If RESET# is held at  $V_{IL}$  but not within  $V_{SS} \pm 0.3$  V, the standby current will be greater.

The RESET# pin may be tied to the system reset circuitry. A system reset would thus also reset the Flash memory, enabling the system to read the boot-up firmware from the Flash memory.

If RESET# is asserted during a program or erase operation, the RY/BY# pin remains a "0" (busy) until the internal reset operation is complete, which requires a time of  $t_{READY}$  (during Embedded Algorithms). The system can thus monitor RY/BY# to determine whether the reset operation is complete. If RESET# is asserted when a program or erase operation is not executing (RY/BY# pin is "1"), the reset operation is completed within a time of  $t_{READY}$  (not during Embedded Algorithms). The system can read data  $t_{RH}$  after the RESET# pin returns to  $V_{IH}$ .

$I_{CC4}$  in the DC Characteristics table represents the reset current. Also refer to AC Characteristics tables for RESET# timing parameters and to Figure 14 for the timing diagram.

### Output Disable Mode

When the OE# input is at  $V_{IH}$ , output from the device is disabled. The output pins are placed in the high impedance state.

**Table 2. Device Bank Divisions**

Device Part Number	Bank 1		Bank 2	
	Megabits	Sector Sizes	Megabits	Sector Sizes
Am29DL322D	4 Mbit	Eight 8 Kbyte/4 Kword, seven 64 Kbyte/32 Kword	28 Mbit	Fifty-six 64 Kbyte/32 Kword
Am29DL323D	8 Mbit	Eight 8 Kbyte/4 Kword, fifteen 64 Kbyte/32 Kword	24 Mbit	Forty-eight 64 Kbyte/32 Kword
Am29DL324D	16 Mbit	Eight 8 Kbyte/4 Kword, thirty-one 64 Kbyte/32 Kword	16 Mbit	Thirty-two 64 Kbyte/32 Kword

**Table 3. Top Boot Sector Addresses**

Am29DL324DT	Am29DL323DT	Am29DL322DT	Sector	Sector Address A20–A12	Sector Size (Kbytes/Kwords)	(x8) Address Range	(x16) Address Range			
Bank 2	Bank 2	Bank 2	SA0	00000xxx	64/32	00000h–00FFFh	00000h–07FFFh			
			SA1	00001xxx	64/32	01000h–01FFFh	00800h–0FFFFh			
			SA2	00010xxx	64/32	02000h–02FFFh	01000h–17FFFh			
			SA3	00011xxx	64/32	03000h–03FFFh	01800h–01FFFh			
			SA4	000100xxx	64/32	04000h–04FFFh	02000h–027FFFh			
			SA5	000101xxx	64/32	05000h–05FFFh	02800h–02FFFh			
			SA6	000110xxx	64/32	06000h–06FFFh	03000h–037FFFh			
			SA7	000111xxx	64/32	07000h–07FFFh	03800h–03FFFh			
			SA8	001000xxx	64/32	08000h–08FFFh	04000h–047FFFh			
			SA9	001001xxx	64/32	09000h–09FFFh	04800h–04FFFh			
			SA10	001010xxx	64/32	0A000h–0AFFFh	05000h–057FFFh			
			SA11	001011xxx	64/32	0B000h–0BFFFh	05800h–05FFFh			
			SA12	001100xxx	64/32	0C000h–0CFFFh	06000h–067FFFh			
			SA13	001101xxx	64/32	0D000h–0DFFFh	06800h–06FFFh			
			SA14	001110xxx	64/32	0E000h–0EFFFh	07000h–077FFFh			
			SA15	001111xxx	64/32	0F000h–0FFFFh	07800h–07FFFh			
			SA16	010000xxx	64/32	10000h–10FFFh	08000h–087FFFh			
			SA17	010001xxx	64/32	11000h–11FFFh	08800h–08FFFh			
			SA18	010010xxx	64/32	12000h–12FFFh	09000h–097FFFh			
			SA19	010011xxx	64/32	13000h–13FFFh	09800h–09FFFh			
			SA20	010100xxx	64/32	14000h–14FFFh	0A000h–0A7FFFh			
			SA21	010101xxx	64/32	15000h–15FFFh	0A800h–0AFFFh			
			SA22	010110xxx	64/32	16000h–16FFFh	0B000h–0B7FFFh			
			SA23	010111xxx	64/32	17000h–17FFFh	0B800h–0BFFFh			
			SA24	011000xxx	64/32	18000h–18FFFh	0C000h–0C7FFFh			
			SA25	011001xxx	64/32	19000h–19FFFh	0C800h–0CFFFh			
			SA26	011010xxx	64/32	1A000h–1AFFFh	0D000h–0D7FFFh			
			SA27	011011xxx	64/32	1B000h–1BFFFh	0D800h–0DFFFh			
			SA28	011100xxx	64/32	1C000h–1CFFFh	0E000h–0E7FFFh			
			SA29	011101xxx	64/32	1D000h–1DFFFh	0E800h–0EFFFh			
			SA30	011110xxx	64/32	1E000h–1EFFFh	0F000h–0F7FFFh			
			SA31	011111xxx	64/32	1F000h–1FFFFh	0F800h–0FFFFh			
			Bank 1	Bank 2	Bank 2	SA32	10000xxx	64/32	20000h–20FFFh	10000h–107FFFh
						SA33	10001xxx	64/32	21000h–21FFFh	10800h–10FFFh
						SA34	10010xxx	64/32	22000h–22FFFh	11000h–117FFFh
SA35	10011xxx	64/32				23000h–23FFFh	11800h–11FFFh			
SA36	100100xxx	64/32				24000h–24FFFh	12000h–127FFFh			
SA37	100101xxx	64/32				25000h–25FFFh	12800h–12FFFh			
SA38	100110xxx	64/32				26000h–26FFFh	13000h–137FFFh			
SA39	100111xxx	64/32				27000h–27FFFh	13800h–13FFFh			
SA40	101000xxx	64/32				28000h–28FFFh	14000h–147FFFh			
SA41	101001xxx	64/32				29000h–29FFFh	14800h–14FFFh			
SA42	101010xxx	64/32				2A000h–2AFFFh	15000h–157FFFh			
SA43	101011xxx	64/32				2B000h–2BFFFh	15800h–15FFFh			
SA44	101100xxx	64/32				2C000h–2CFFFh	16000h–167FFFh			
SA45	101101xxx	64/32				2D000h–2DFFFh	16800h–16FFFh			
SA46	101110xxx	64/32				2E000h–2EFFFh	17000h–177FFFh			
SA47	101111xxx	64/32				2F000h–2FFFFh	17800h–17FFFh			

**Table 3. Top Boot Sector Addresses (Continued)**

Am29DL324DT	Am29DL323DT	Am29DL322DT	Sector	Sector Address A20–A12	Sector Size (Kbytes/Kwords)	(x8) Address Range	(x16) Address Range
Bank 1	Bank 1	Bank 2	SA48	110000xxx	64/32	300000h–30FFFFh	180000h–187FFFh
			SA49	110001xxx	64/32	310000h–31FFFFh	188000h–18FFFFh
			SA50	110010xxx	64/32	320000h–32FFFFh	190000h–197FFFh
			SA51	110011xxx	64/32	330000h–33FFFFh	198000h–19FFFFh
			SA52	110100xxx	64/32	340000h–34FFFFh	1A0000h–1A7FFFh
			SA53	110101xxx	64/32	350000h–35FFFFh	1A8000h–1AFFFFh
			SA54	110110xxx	64/32	360000h–36FFFFh	1B0000h–1B7FFFh
		SA55	110111xxx	64/32	370000h–37FFFFh	1B8000h–1BFFFFh	
		SA56	111000xxx	64/32	380000h–38FFFFh	1C0000h–1C7FFFh	
		SA57	111001xxx	64/32	390000h–39FFFFh	1C8000h–1CFFFFh	
		SA58	111010xxx	64/32	3A0000h–3AFFFFh	1D0000h–1D7FFFh	
		SA59	111011xxx	64/32	3B0000h–3BFFFFh	1D8000h–1DFFFFh	
		SA60	111100xxx	64/32	3C0000h–3CFFFFh	1E0000h–1E7FFFh	
		SA61	111101xxx	64/32	3D0000h–3DFFFFh	1E8000h–1EFFFFh	
		SA62	111110xxx	64/32	3E0000h–3EFFFFh	1F0000h–1F7FFFh	
		SA63	111111000	8/4	3F0000h–3F1FFFh	1F8000h–1F8FFFh	
		SA64	111111001	8/4	3F2000h–3F3FFFh	1F9000h–1F9FFFh	
		SA65	111111010	8/4	3F4000h–3F5FFFh	1FA000h–1FAFFFh	
		SA66	111111011	8/4	3F6000h–3F7FFFh	1FB000h–1FBFFFh	
		SA67	111111100	8/4	3F8000h–3F9FFFh	1FC000h–1FCFFFh	
SA68	111111101	8/4	3FA000h–3FBFFFh	1FD000h–1FDFFFh			
SA69	111111110	8/4	3FC000h–3FDFFFh	1FE000h–1FEFFFh			
SA70	111111111	8/4	3FE000h–3FFFFFFh	1FF000h–1FFFFFFh			

**Note:** The address range is A20:A-1 in byte mode (BYTE#=V<sub>IL</sub>) or A20:A0 in word mode (BYTE#=V<sub>IH</sub>). The bank address bits are A20–A18 for Am29DL322DT, A20 and A19 for Am29DL323DT, and A20 for Am29DL324DT.

**Table 4. Top Boot SecS<sub>i</sub>™ Sector Addresses**

Device	Sector Address A20–A12	Sector Size	(x8) Address Range	(x16) Address Range
Am29DL322DT, Am29DL323DT, Am29DL324DT	111111xxx	64/32	3F0000h–3FFFFFFh	1F8000h–1FFFFFFh

**Table 5. Bottom Boot Sector Addresses**

Am29DL324DB	Am29DL323DB	Am29DL322DB	Sector	Sector Address A20–A12	Sector Size (Kbytes/Kwords)	(x8) Address Range	(x16) Address Range
Bank 1	Bank 1	Bank 1	SA0	000000000	8/4	000000h-001FFFh	000000h–000FFFh
			SA1	000000001	8/4	002000h-003FFFh	001000h–001FFFh
			SA2	000000010	8/4	004000h-005FFFh	002000h–002FFFh
			SA3	000000011	8/4	006000h-007FFFh	003000h–003FFFh
			SA4	000000100	8/4	008000h-009FFFh	004000h–004FFFh
			SA5	000000101	8/4	00A000h-00BFFFh	005000h–005FFFh
			SA6	000000110	8/4	00C000h-00DFFFh	006000h–006FFFh
			SA7	000000111	8/4	00E000h-00FFFFh	007000h–007FFFh
			SA8	000001xxx	64/32	010000h-01FFFFh	008000h–00FFFFh
			SA9	000010xxx	64/32	020000h-02FFFFh	010000h–017FFFh
			SA10	000011xxx	64/32	030000h-03FFFFh	018000h–01FFFFh
			SA11	000100xxx	64/32	040000h-04FFFFh	020000h–027FFFh
			SA12	000101xxx	64/32	050000h-05FFFFh	028000h–02FFFFh
			SA13	000110xxx	64/32	060000h-06FFFFh	030000h–037FFFh
		SA14	000111xxx	64/32	070000h-07FFFFh	038000h–03FFFFh	
		SA15	001000xxx	64/32	080000h-08FFFFh	040000h–047FFFh	
		SA16	001001xxx	64/32	090000h-09FFFFh	048000h–04FFFFh	
		SA17	001010xxx	64/32	0A0000h-0AFFFFh	050000h–057FFFh	
		SA18	001011xxx	64/32	0B0000h-0BFFFFh	058000h–05FFFFh	
		SA19	001100xxx	64/32	0C0000h-0CFFFFh	060000h–067FFFh	
		SA20	001101xxx	64/32	0D0000h-0DFFFFh	068000h–06FFFFh	
		SA21	001110xxx	64/32	0E0000h-0EFFFFh	070000h–077FFFh	
		SA22	001111xxx	64/32	0F0000h-0FFFFFh	078000h–07FFFFh	
		SA23	010000xxx	64/32	100000h-10FFFFh	080000h–087FFFh	
		SA24	010001xxx	64/32	110000h-11FFFFh	088000h–08FFFFh	
		SA25	010010xxx	64/32	120000h-12FFFFh	090000h–097FFFh	
		SA26	010011xxx	64/32	130000h-13FFFFh	098000h–09FFFFh	
		SA27	010100xxx	64/32	140000h-14FFFFh	0A0000h–0A7FFFh	
	SA28	010101xxx	64/32	150000h-15FFFFh	0A8000h–0AFFFFh		
	SA29	010110xxx	64/32	160000h-16FFFFh	0B0000h–0B7FFFh		
	SA30	010111xxx	64/32	170000h-17FFFFh	0B8000h–0BFFFFh		
	SA31	011000xxx	64/32	180000h-18FFFFh	0C0000h–0C7FFFh		
	SA32	011001xxx	64/32	190000h-19FFFFh	0C8000h–0CFFFFh		
	SA33	011010xxx	64/32	1A0000h-1AFFFFh	0D0000h–0D7FFFh		
	SA34	011011xxx	64/32	1B0000h-1BFFFFh	0D8000h–0DFFFFh		
	SA35	011100xxx	64/32	1C0000h-1CFFFFh	0E0000h–0E7FFFh		
	SA36	011101xxx	64/32	1D0000h-1DFFFFh	0E8000h–0EFFFFh		
	SA37	011110xxx	64/32	1E0000h-1EFFFFh	0F0000h–0F7FFFh		
	SA38	011111xxx	64/32	1F0000h-1FFFFFh	0F8000h–0FFFFFh		
	SA39	100000xxx	64/32	200000h-20FFFFh	100000h–107FFFh		
	SA40	100001xxx	64/32	210000h-21FFFFh	108000h–10FFFFh		
	SA41	100010xxx	64/32	220000h-22FFFFh	110000h–117FFFh		
	SA42	100011xxx	64/32	230000h-23FFFFh	118000h–11FFFFh		
	SA43	100100xxx	64/32	240000h-24FFFFh	120000h–127FFFh		
	SA44	100101xxx	64/32	250000h-25FFFFh	128000h–12FFFFh		
	SA45	100110xxx	64/32	260000h-26FFFFh	130000h–137FFFh		
	SA46	100111xxx	64/32	270000h-27FFFFh	138000h–13FFFFh		
SA47	101000xxx	64/32	280000h-28FFFFh	140000h–147FFFh			
Bank 2	Bank 2	Bank 2					

**Table 5. Bottom Boot Sector Addresses (Continued)**

Am29DL324DB	Am29DL323DB	Am29DL322DB	Sector	Sector Address A20–A12	Sector Size (Kbytes/Kwords)	(x8) Address Range	(x16) Address Range
Bank 2	Bank 2	Bank 2	SA48	101001xxx	64/32	290000h-29FFFFh	148000h-14FFFFh
			SA49	101010xxx	64/32	2A0000h-2AFFFFh	150000h-157FFFh
			SA50	101011xxx	64/32	2B0000h-2BFFFFh	158000h-15FFFFh
			SA51	101100xxx	64/32	2C0000h-2CFFFFh	160000h-167FFFh
			SA52	101101xxx	64/32	2D0000h-2DFFFFh	168000h-16FFFFh
			SA53	101110xxx	64/32	2E0000h-2EFFFFh	170000h-177FFFh
			SA54	101111xxx	64/32	2F0000h-2FFFFFFh	178000h-17FFFFh
			SA55	111000xxx	64/32	300000h-30FFFFh	180000h-187FFFh
			SA56	110001xxx	64/32	310000h-31FFFFh	188000h-18FFFFh
			SA57	110010xxx	64/32	320000h-32FFFFh	190000h-197FFFh
			SA58	110011xxx	64/32	330000h-33FFFFh	198000h-19FFFFh
			SA59	110100xxx	64/32	340000h-34FFFFh	1A0000h-1A7FFFh
			SA60	110101xxx	64/32	350000h-35FFFFh	1A8000h-1AFFFFh
			SA61	110110xxx	64/32	360000h-36FFFFh	1B0000h-1B7FFFh
			SA62	110111xxx	64/32	370000h-37FFFFh	1B8000h-1BFFFFh
			SA63	111000xxx	64/32	380000h-38FFFFh	1C0000h-1C7FFFh
			SA64	111001xxx	64/32	390000h-39FFFFh	1C8000h-1CFFFFh
			SA65	111010xxx	64/32	3A0000h-3AFFFFh	1D0000h-1D7FFFh
			SA66	111011xxx	64/32	3B0000h-3BFFFFh	1D8000h-1DFFFFh
			SA67	111100xxx	64/32	3C0000h-3CFFFFh	1E0000h-1E7FFFh
SA68	111101xxx	64/32	3D0000h-3DFFFFh	1E8000h-1EFFFFh			
SA69	111110xxx	64/32	3E0000h-3EFFFFh	1F0000h-1F7FFFh			
SA70	111111xxx	64/32	3F0000h-3FFFFFFh	1F8000h-1FFFFFFh			

**Note:** The address range is A20:A-1 in byte mode (BYTE#=V<sub>IL</sub>) or A20:A0 in word mode (BYTE#=V<sub>IH</sub>). The bank address bits are A20–A18 for Am29DL322DB, A20 and A19 for Am29DL323DB, and A20 for Am29DL324DB.

**Table 6. Bottom Boot SecSi™ Sector Addresses**

Device	Sector Address A20–A12	Sector Size	(x8) Address Range	(x16) Address Range
Am29DL322DB, Am29DL323DB, Am29DL324DB	000000xxx	64/32	000000h-00FFFFh	00000h-07FFFh

## Autoselect Mode

The autoselect mode provides manufacturer and device identification, and sector protection verification, through identifier codes output on DQ7–DQ0. This mode is primarily intended for programming equipment to automatically match a device to be programmed with its corresponding programming algorithm. However, the autoselect codes can also be accessed in-system through the command register.

When using programming equipment, the autoselect mode requires  $V_{ID}$  (8.5 V to 12.5 V) on address pin A9. Address pins A6, A1, and A0 must be as shown in

Table 7. In addition, when verifying sector protection, the sector address must appear on the appropriate highest order address bits (see Tables 3–6). Table 7 shows the remaining address bits that are don't care. When all necessary bits have been set as required, the programming equipment may then read the corresponding identifier code on DQ7–DQ0.

To access the autoselect codes in-system, the host system can issue the autoselect command via the command register, as shown in Table 14. This method does not require  $V_{ID}$ . Refer to the Autoselect Command Sequence section for more information.

**Table 7. Autoselect Codes, (High Voltage Method)**

Description	CE#	OE#	WE#	A20 to A12	A11 to A10	A9	A8 to A7	A6	A5 to A2	A1	A0	DQ8 to DQ15		DQ7 to DQ0
												BYTE# = $V_{IH}$	BYTE# = $V_{IL}$	
Manufacturer ID: AMD	L	L	H	BA	X	$V_{ID}$	X	L	X	L	L	X	X	01h
Device ID: Am29DL322D	L	L	H	BA	X	$V_{ID}$	X	L	X	L	H	22h	X	55h (T), 56h (B)
Device ID: Am29DL323D	L	L	H	BA	X	$V_{ID}$	X	L	X	L	H	22h	X	50h (T), 53h (B)
Device ID: Am29DL324D	L	L	H	BA	X	$V_{ID}$	X	L	X	L	H	22h	X	5Ch (T), 5Fh (B)
Sector Protection Verification	L	L	H	SA	X	$V_{ID}$	X	L	X	H	L	X	X	01h (protected), 00h (unprotected)
SecSi™ Indicator Bit (DQ7)	L	L	H	BA	X	$V_{ID}$	X	L	X	H	H	X	X	81h (factory locked), 01h (not factory locked)

**Legend:** T = Top Boot Block, B = Bottom Boot Block, L = Logic Low =  $V_{IL}$ , H = Logic High =  $V_{IH}$ , BA = Bank Address, SA = Sector Address, X = Don't care.

## Sector/Sector Block Protection and Unprotection

(Note: For the following discussion, the term “sector” applies to both sectors and sector blocks. A sector block consists of two or more adjacent sectors that are protected or unprotected at the same time (see Tables 8 and 9).

The hardware sector protection feature disables both program and erase operations in any sector. The hardware sector unprotection feature re-enables both program and erase operations in previously protected sectors. Sector protection/unprotection can be implemented via two methods.

**Table 8. Top Boot Sector/Sector Block Addresses for Protection/Unprotection**

Sector	A20–A12	Sector/ Sector Block Size
SA0	000000XXX	64 Kbytes
SA1-SA3	000001XXX, 000010XXX 000011XXX	192 (3x64) Kbytes
SA4-SA7	0001XXXXX	256 (4x64) Kbytes
SA8-SA11	0010XXXXX	256 (4x64) Kbytes
SA12-SA15	0011XXXXX	256 (4x64) Kbytes
SA16-SA19	0100XXXXX	256 (4x64) Kbytes
SA20-SA23	0101XXXXX	256 (4x64) Kbytes
SA24-SA27	0110XXXXX	256 (4x64) Kbytes
SA28-SA31	0111XXXXX	256 (4x64) Kbytes
SA32-SA35	1000XXXXX	256 (4x64) Kbytes
SA36-SA39	1001XXXXX	256 (4x64) Kbytes
SA40-SA43	1010XXXXX	256 (4x64) Kbytes
SA44-SA47	1011XXXXX	256 (4x64) Kbytes
SA48-SA51	1100XXXXX	256 (4x64) Kbytes
SA52-SA55	1101XXXXX	256 (4x64) Kbytes
SA56-SA59	1110XXXXX	256 (4x64) Kbytes
SA60-SA62	111100XXX, 111101XXX, 111110XXX	192 (4x64) Kbytes
SA63	111111000	8 Kbytes
SA64	111111001	8 Kbytes
SA65	111111010	8 Kbytes
SA66	111111011	8 Kbytes
SA67	111111100	8 Kbytes
SA68	111111101	8 Kbytes
SA69	111111110	8 Kbytes
SA70	111111111	8 Kbytes

**Table 9. Bottom Boot Sector/Sector Block Addresses for Protection/Unprotection**

Sector	A20–A12	Sector/Sector Block Size
SA70	111111XXX	64 Kbytes
SA69-SA67	111110XXX, 111101XXX, 111100XXX	192 (3x64) Kbytes
SA66-SA63	1110XXXXX	256 (4x64) Kbytes
SA62-SA59	1101XXXXX	256 (4x64) Kbytes
SA58-SA55	1100XXXXX	256 (4x64) Kbytes
SA54-SA51	1011XXXXX	256 (4x64) Kbytes
SA50-SA47	1010XXXXX	256 (4x64) Kbytes
SA46-SA43	1001XXXXX	256 (4x64) Kbytes
SA42-SA39	1000XXXXX	256 (4x64) Kbytes
SA38-SA35	0111XXXXX	256 (4x64) Kbytes
SA34-SA31	0110XXXXX	256 (4x64) Kbytes
SA30-SA27	0101XXXXX	256 (4x64) Kbytes
SA26-SA23	0100XXXXX	256 (4x64) Kbytes
SA22–SA19	0011XXXXX	256 (4x64) Kbytes
SA18-SA15	0010XXXXX	256 (4x64) Kbytes
SA14-SA11	0001XXXXX	256 (4x64) Kbytes
SA10-SA8	000011XXX, 000010XXX, 000001XXX	192 (3x64) Kbytes
SA7	000000111	8 Kbytes
SA6	000000110	8 Kbytes
SA5	000000101	8 Kbytes
SA4	000000100	8 Kbytes
SA3	000000011	8 Kbytes
SA2	000000010	8 Kbytes
SA1	000000001	8 Kbytes
SA0	000000000	8 Kbytes

The primary method requires  $V_{ID}$  on the RESET# pin only, and can be implemented either in-system or via programming equipment. Figure 2 shows the algorithms and Figure 25 shows the timing diagram. This method uses standard microprocessor bus cycle timing. For sector unprotect, all unprotected sectors must first be protected prior to the first sector unprotect write cycle.

The sector unprotect algorithm unprotects all sectors in parallel. All previously protected sectors must be individually re-protected. To change data in protected sectors efficiently, the temporary sector unprotect function is available. See “Temporary Sector Unprotect”.



The alternate method intended only for programming equipment requires  $V_{ID}$  on address pin A9 and OE#. This method is compatible with programmer routines written for earlier 3.0 volt-only AMD flash devices. Publication number 22244 contains further details; contact an AMD representative to request a copy.

The device is shipped with all sectors unprotected. AMD offers the option of programming and protecting sectors at its factory prior to shipping the device through AMD's ExpressFlash™ Service. Contact an AMD representative for details.

It is possible to determine whether a sector is protected or unprotected. See the Autoselect Mode section for details.

### Write Protect (WP#)

The Write Protect function provides a hardware method of protecting certain boot sectors without using  $V_{ID}$ . This function is one of two provided by the WP#/ACC pin.

If the system asserts  $V_{IL}$  on the WP#/ACC pin, the device disables program and erase functions in the two "outermost" 8 Kbyte boot sectors independently of whether those sectors were protected or unprotected using the method described in "Sector/Sector Block Protection and Unprotection". The two outermost 8 Kbyte boot sectors are the two sectors containing the lowest addresses in a bottom-boot-configured device, or the two sectors containing the highest addresses in a top-boot-configured device.

If the system asserts  $V_{IH}$  on the WP#/ACC pin, the device reverts to whether the two outermost 8K Byte boot sectors were last set to be protected or unprotected. That is, sector protection or unprotection for these two sectors depends on whether they were last protected or unprotected using the method described in "Sector/Sector Block Protection and Unprotection".

Note that the WP#/ACC pin must not be left floating or unconnected; inconsistent behavior of the device may result.

### Temporary Sector Unprotect

(Note: For the following discussion, the term "sector" applies to both sectors and sector blocks. A sector block consists of two or more adjacent sectors that are protected or unprotected at the same time (see Tables 8 and 9).

This feature allows temporary unprotection of previously protected sectors to change data in-system. The Sector Unprotect mode is activated by setting the RESET# pin to  $V_{ID}$  (8.5 V – 12.5 V). During this mode, formerly protected sectors can be programmed or erased by selecting the sector addresses. Once  $V_{ID}$  is removed from the RESET# pin, all the previously protected sectors are protected again. Figure 1 shows the algorithm, and Figure 24 shows the timing diagrams, for this feature.

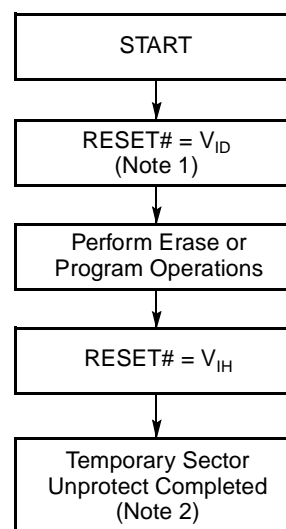

**Notes:**

1. All protected sectors unprotected (If WP#/ACC =  $V_{IL}$ , outermost boot sectors will remain protected).
2. All previously protected sectors are protected once again.

**Figure 1. Temporary Sector Unprotect Operation**

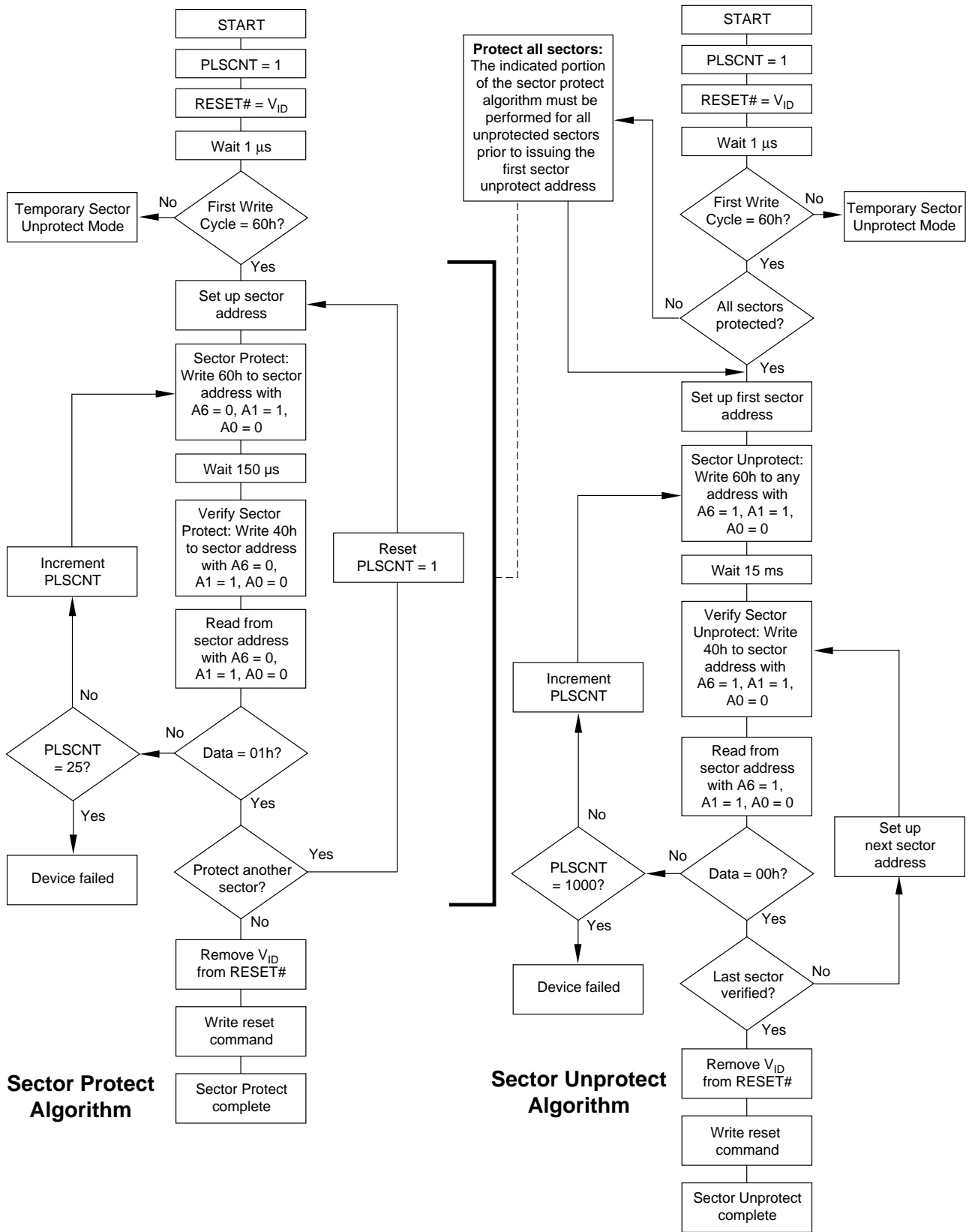

Figure 2. In-System Sector Protection/ Sector Unprotection Algorithms

## SecSi™ (Secured Silicon) Sector Flash Memory Region

The SecSi (Secured Silicon) Sector feature provides a Flash memory region that enables permanent part identification through an Electronic Serial Number (ESN). The SecSi Sector uses a SecSi Sector Indicator Bit (DQ7) to indicate whether or not the SecSi Sector is locked when shipped from the factory. This bit is permanently set at the factory and cannot be changed, which prevents cloning of a factory locked part. This ensures the security of the ESN once the product is shipped to the field. **Current version of device has 64 Kbytes; future versions will have only 256 bytes. This should be considered during system design.**

AMD offers the device with the SecSi Sector either factory locked or customer lockable. The factory-locked version is always protected when shipped from the factory, and has the SecSi (Secured Silicon) Sector Indicator Bit permanently set to a “1.” The customer-lockable version is shipped with the SecSi Sector unprotected, allowing customers to utilize the that sector in any manner they choose. The customer-lockable version has the SecSi (Secured Silicon) Sector Indicator Bit permanently set to a “0.” Thus, the SecSi Sector Indicator Bit prevents customer-lockable devices from being used to replace devices that are factory locked.

The system accesses the SecSi Sector through a command sequence (see “Enter SecSi™ Sector/Exit SecSi Sector Command Sequence”). After the system has written the Enter SecSi Sector command sequence, it may read the SecSi Sector by using the addresses normally occupied by the boot sectors. This mode of operation continues until the system issues the Exit SecSi Sector command sequence, or until power is removed from the device. On power-up, or following a hardware reset, the device reverts to sending commands to the boot sectors.

### Factory Locked: SecSi Sector Programmed and Protected At the Factory

In a factory locked device, the SecSi Sector is protected when the device is shipped from the factory. The SecSi Sector cannot be modified in any way. The device is available preprogrammed with one of the following:

- A random, secure ESN only
- Customer code through the ExpressFlash service
- Both a random, secure ESN and customer code through the ExpressFlash service.

In devices that have an ESN, a Bottom Boot device will have the 16-byte ESN at addresses 000000h–000007h in word mode (or

000000h–00000Fh in byte mode). In the Top Boot device the ESN will be at addresses 1F8000h–1F8007h in word mode (or addresses 3F0000h–3F000Fh in byte mode). Note that in upcoming top boot versions of this device, the ESN will be located at addresses 1FF000h–1FF007h in word mode (or addresses 3FE000h–3FE00Fh in byte mode).

Customers may opt to have their code programmed by AMD through the AMD ExpressFlash service. AMD programs the customer's code, with or without the random ESN. The devices are then shipped from AMD's factory with the SecSi Sector permanently locked. Contact an AMD representative for details on using AMD's ExpressFlash service.

### Customer Lockable: SecSi Sector NOT Programmed or Protected At the Factory

If the security feature is not required, the SecSi Sector can be treated as an additional Flash memory space, expanding the size of the available Flash array. **Current version of device has 64 Kbytes; future versions will have only 256 bytes. This should be considered during system design. Additionally, note the change in the location of the ESN in upcoming top boot factory locked devices.** The SecSi Sector can be read, programmed, and erased as often as required. (*Note that in upcoming versions of this device, the SecSi Sector erase function will not be available.*) Note that the accelerated programming (ACC) and unlock bypass functions are not available when programming the SecSi Sector.

The SecSi Sector area can be protected using one of the following procedures:

- Write the three-cycle Enter SecSi Sector Region command sequence, and then follow the in-system sector protect algorithm as shown in Figure 2, except that *RESET#* may be at either  $V_{IH}$  or  $V_{ID}$ . This allows in-system protection of the SecSi Sector without raising any device pin to a high voltage. Note that this method is only applicable to the SecSi Sector.
- Write the three-cycle Enter SecSi Sector Region command sequence, and then use the alternate method of sector protection described in the “Sector/Sector Block Protection and Unprotection” section.

Once the SecSi Sector is locked and verified, the system must write the Exit SecSi Sector Region command sequence to return to reading and writing the remainder of the array.

The SecSi Sector protection must be used with caution since, once protected, there is no procedure available for unprotecting the SecSi Sector area and none of the bits in the SecSi Sector memory space can be modified in any way.

## Hardware Data Protection

The command sequence requirement of unlock cycles for programming or erasing provides data protection against inadvertent writes (refer to Table 14 for command definitions). In addition, the following hardware data protection measures prevent accidental erasure or programming, which might otherwise be caused by spurious system level signals during  $V_{CC}$  power-up and power-down transitions, or from system noise.

### Low $V_{CC}$ Write Inhibit

When  $V_{CC}$  is less than  $V_{LKO}$ , the device does not accept any write cycles. This protects data during  $V_{CC}$  power-up and power-down. The command register and all internal program/erase circuits are disabled, and the device resets to the read mode. Subsequent writes are ignored until  $V_{CC}$  is greater than  $V_{LKO}$ . The system must provide the proper signals to the control pins to prevent unintentional writes when  $V_{CC}$  is greater than  $V_{LKO}$ .

### Write Pulse “Glitch” Protection

Noise pulses of less than 5 ns (typical) on OE#, CE# or WE# do not initiate a write cycle.

### Logical Inhibit

Write cycles are inhibited by holding any one of OE# =  $V_{IL}$ , CE# =  $V_{IH}$  or WE# =  $V_{IH}$ . To initiate a write cycle, CE# and WE# must be a logical zero while OE# is a logical one.

### Power-Up Write Inhibit

If WE# = CE# =  $V_{IL}$  and OE# =  $V_{IH}$  during power up, the device does not accept commands on the rising

edge of WE#. The internal state machine is automatically reset to the read mode on power-up.

## COMMON FLASH MEMORY INTERFACE (CFI)

The Common Flash Interface (CFI) specification outlines device and host system software interrogation handshake, which allows specific vendor-specified software algorithms to be used for entire families of devices. Software support can then be device-independent, JEDEC ID-independent, and forward- and backward-compatible for the specified flash device families. Flash vendors can standardize their existing interfaces for long-term compatibility.

This device enters the CFI Query mode when the system writes the CFI Query command, 98h, to address 55h in word mode (or address AAh in byte mode), any time the device is ready to read array data. The system can read CFI information at the addresses given in Tables 10–13. To terminate reading CFI data, the system must write the reset command. The CFI Query mode is not accessible when the device is executing an Embedded Program or Embedded Erase algorithm.

The system can also write the CFI query command when the device is in the autoselect mode. The device enters the CFI query mode, and the system can read CFI data at the addresses given in Tables 10–13. The system must write the reset command to return the device to the autoselect mode.

For further information, please refer to the CFI Specification and CFI Publication 100, available via the World Wide Web at <http://www.amd.com/products/nvd/over>

**Table 10. CFI Query Identification String**

Addresses (Word Mode)	Addresses (Byte Mode)	Data	Description
10h 11h 12h	20h 22h 24h	0051h 0052h 0059h	Query Unique ASCII string “QRY”
13h 14h	26h 28h	0002h 0000h	Primary OEM Command Set
15h 16h	2Ah 2Ch	0040h 0000h	Address for Primary Extended Table
17h 18h	2Eh 30h	0000h 0000h	Alternate OEM Command Set (00h = none exists)
19h 1Ah	32h 34h	0000h 0000h	Address for Alternate OEM Extended Table (00h = none exists)

Table 11. System Interface String

Addresses (Word Mode)	Addresses (Byte Mode)	Data	Description
1Bh	36h	0027h	V <sub>CC</sub> Min. (write/erase) D7–D4: volt, D3–D0: 100 millivolt
1Ch	38h	0036h	V <sub>CC</sub> Max. (write/erase) D7–D4: volt, D3–D0: 100 millivolt
1Dh	3Ah	0000h	V <sub>PP</sub> Min. voltage (00h = no V <sub>PP</sub> pin present)
1Eh	3Ch	0000h	V <sub>PP</sub> Max. voltage (00h = no V <sub>PP</sub> pin present)
1Fh	3Eh	0004h	Typical timeout per single byte/word write 2 <sup>N</sup> μs
20h	40h	0000h	Typical timeout for Min. size buffer write 2 <sup>N</sup> μs (00h = not supported)
21h	42h	000Ah	Typical timeout per individual block erase 2 <sup>N</sup> ms
22h	44h	0000h	Typical timeout for full chip erase 2 <sup>N</sup> ms (00h = not supported)
23h	46h	0005h	Max. timeout for byte/word write 2 <sup>N</sup> times typical
24h	48h	0000h	Max. timeout for buffer write 2 <sup>N</sup> times typical
25h	4Ah	0004h	Max. timeout per individual block erase 2 <sup>N</sup> times typical
26h	4Ch	0000h	Max. timeout for full chip erase 2 <sup>N</sup> times typical (00h = not supported)

Table 12. Device Geometry Definition

Addresses (Word Mode)	Addresses (Byte Mode)	Data	Description
27h	4Eh	0016h	Device Size = 2 <sup>N</sup> byte
28h 29h	50h 52h	0000h 0000h	Flash Device Interface description (refer to CFI publication 100)
2Ah 2Bh	54h 56h	0000h 0000h	Max. number of bytes in multi-byte write = 2 <sup>N</sup> (00h = not supported)
2Ch	58h	0002h	Number of Erase Block Regions within device
2Dh 2Eh 2Fh 30h	5Ah 5Ch 5Eh 60h	0007h 0000h 0020h 0000h	Erase Block Region 1 Information (refer to the CFI specification or CFI publication 100)
31h 32h 33h 34h	62h 64h 66h 68h	003Eh 0000h 0000h 0001h	Erase Block Region 2 Information
35h 36h 37h 38h	6Ah 6Ch 6Eh 70h	0000h 0000h 0000h 0000h	Erase Block Region 3 Information
39h 3Ah 3Bh 3Ch	72h 74h 76h 78h	0000h 0000h 0000h 0000h	Erase Block Region 4 Information

**Table 13. Primary Vendor-Specific Extended Query**

Addresses (Word Mode)	Addresses (Byte Mode)	Data	Description
40h 41h 42h	80h 82h 84h	0050h 0052h 0049h	Query-unique ASCII string "PRI"
43h	86h	0031h	Major version number, ASCII
44h	88h	0031h	Minor version number, ASCII
45h	8Ah	0000h	Address Sensitive Unlock (Bits 1-0) 0 = Required, 1 = Not Required Silicon Revision Number (Bits 7-2)
46h	8Ch	0002h	Erase Suspend 0 = Not Supported, 1 = To Read Only, 2 = To Read & Write
47h	8Eh	0001h	Sector Protect 0 = Not Supported, X = Number of sectors in per group
48h	90h	0001h	Sector Temporary Unprotect 00 = Not Supported, 01 = Supported
49h	92h	0004h	Sector Protect/Unprotect scheme 04 = 29LV800 mode
4Ah	94h	00XXh (See Note)	Simultaneous Operation 00 = Not Supported, X = Number of Sectors in Bank 2 (Uniform Bank)
4Bh	96h	0000h	Burst Mode Type 00 = Not Supported, 01 = Supported
4Ch	98h	0000h	Page Mode Type 00 = Not Supported, 01 = 4 Word Page, 02 = 8 Word Page
4Dh	9Ah	0085h	ACC (Acceleration) Supply Minimum 00h = Not Supported, D7-D4: Volt, D3-D0: 100 mV
4Eh	9Ch	0095h	ACC (Acceleration) Supply Maximum 00h = Not Supported, D7-D4: Volt, D3-D0: 100 mV
4Fh	9Eh	000Xh	Top/Bottom Boot Sector Flag 02h = Bottom Boot Device, 03h = Top Boot Device

**Note:**

The number of sectors in Bank 2 is device dependent.  
 Am29DL322 = 38h, Am29DL323 = 30h, Am29DL324 = 20h

**COMMAND DEFINITIONS**

Writing specific address and data commands or sequences into the command register initiates device operations. Table 14 defines the valid register command sequences. Writing **incorrect address and data values** or writing them in the **improper sequence** resets the device to reading array data.

All addresses are latched on the falling edge of WE# or CE#, whichever happens later. All data is latched on the rising edge of WE# or CE#, whichever happens first. Refer to the AC Characteristics section for timing diagrams.

**Reading Array Data**

The device is automatically set to reading array data after device power-up. No commands are required to retrieve data. Each bank is ready to read array data after completing an Embedded Program or Embedded Erase algorithm.

After the device accepts an Erase Suspend command, the corresponding bank enters the erase-suspend-read mode, after which the system can read data from any non-erase-suspended sector within the same bank. After completing a programming operation in the Erase Suspend mode, the system may once

again read array data with the same exception. See the Erase Suspend/Erase Resume Commands section for more information.

The system *must* issue the reset command to return a bank to the read (or erase-suspend-read) mode if DQ5 goes high during an active program or erase operation, or if the bank is in the autoselect mode. See the next section, Reset Command, for more information.

See also Requirements for Reading Array Data in the Device Bus Operations section for more information. The Read-Only Operations table provides the read parameters, and Figure 13 shows the timing diagram.

## Reset Command

Writing the reset command resets the banks to the read or erase-suspend-read mode. Address bits are don't cares for this command.

The reset command may be written between the sequence cycles in an erase command sequence before erasing begins. This resets the bank to which the system was writing to the read mode. Once erasure begins, however, the device ignores reset commands until the operation is complete.

The reset command may be written between the sequence cycles in a program command sequence before programming begins. This resets the bank to which the system was writing to the read mode. If the program command sequence is written to a bank that is in the Erase Suspend mode, writing the reset command returns that bank to the erase-suspend-read mode. Once programming begins, however, the device ignores reset commands until the operation is complete.

The reset command may be written between the sequence cycles in an autoselect command sequence. Once in the autoselect mode, the reset command must be written to return to the read mode. If a bank entered the autoselect mode while in the Erase Suspend mode, writing the reset command returns that bank to the erase-suspend-read mode.

If DQ5 goes high during a program or erase operation, writing the reset command returns the banks to the read mode (or erase-suspend-read mode if that bank was in Erase Suspend).

## Autoselect Command Sequence

The autoselect command sequence allows the host system to access the manufacturer and device codes, and determine whether or not a sector is protected. Table 14 shows the address and data requirements. This method is an alternative to that shown in Table 7, which is intended for PROM programmers and requires  $V_{ID}$  on address pin A9. The autoselect command sequence may be written to an address within a

bank that is either in the read or erase-suspend-read mode. The autoselect command may not be written while the device is actively programming or erasing in the other bank.

The autoselect command sequence is initiated by first writing two unlock cycles. This is followed by a third write cycle that contains the bank address and the autoselect command. The bank then enters the autoselect mode. The system may read at any address within the same bank any number of times without initiating another autoselect command sequence:

- A read cycle at address (BA)XX00h (where BA is the bank address) returns the manufacturer code.
- A read cycle at address (BA)XX01h in word mode (or (BA)XX02h in byte mode) returns the device code.
- A read cycle to an address containing a sector address (SA) within the same bank, and the address 02h on A7–A0 in word mode (or the address 04h on A6–A-1 in byte mode) returns 01h if the sector is protected, or 00h if it is unprotected. (Refer to Tables 3–6 for valid sector addresses).

The system must write the reset command to return to the read mode (or erase-suspend-read mode if the bank was previously in Erase Suspend).

## Enter SecSi™ Sector/Exit SecSi Sector Command Sequence

The SecSi Sector region provides a secured data area containing a random, sixteen-byte electronic serial number (ESN). The system can access the SecSi Sector region by issuing the three-cycle Enter SecSi Sector command sequence. The device continues to access the SecSi Sector region until the system issues the four-cycle Exit SecSi Sector command sequence. The Exit SecSi Sector command sequence returns the device to normal operation. The SecSi Sector is not accessible when the device is executing an Embedded Program or Embedded Erase algorithm. Table 14 shows the address and data requirements for both command sequences. See also “SecSi™ (Secured Silicon) Sector Flash Memory Region” for further information.

## Byte/Word Program Command Sequence

The system may program the device by word or byte, depending on the state of the BYTE# pin. Programming is a four-bus-cycle operation. The program command sequence is initiated by writing two unlock write cycles, followed by the program set-up command. The program address and data are written next, which in turn initiate the Embedded Program algorithm. The system is *not* required to provide further controls or timings. The device automatically provides internally generated program pulses and verifies the pro-

grammed cell margin. Table 14 shows the address and data requirements for the byte program command sequence.

When the Embedded Program algorithm is complete, that bank then returns to the read mode and addresses are no longer latched. The system can determine the status of the program operation by using DQ7, DQ6, or RY/BY#. Refer to the Write Operation Status section for information on these status bits.

Any commands written to the device during the Embedded Program Algorithm are ignored. Note that a **hardware reset** immediately terminates the program operation. The program command sequence should be reinitiated once that bank has returned to the read mode, to ensure data integrity.

Programming is allowed in any sequence and across sector boundaries. **A bit cannot be programmed from “0” back to a “1.”** Attempting to do so may cause that bank to set DQ5 = 1, or cause the DQ7 and DQ6 status bits to indicate the operation was successful. However, a succeeding read will show that the data is still “0.” Only erase operations can convert a “0” to a “1.”

**Unlock Bypass Command Sequence**

The unlock bypass feature allows the system to program bytes or words to a bank faster than using the standard program command sequence. The unlock bypass command sequence is initiated by first writing two unlock cycles. This is followed by a third write cycle containing the unlock bypass command, 20h. That bank then enters the unlock bypass mode. A two-cycle unlock bypass program command sequence is all that is required to program in this mode. The first cycle in this sequence contains the unlock bypass program command, A0h; the second cycle contains the program address and data. Additional data is programmed in the same manner. This mode dispenses with the initial two unlock cycles required in the standard program command sequence, resulting in faster total programming time. Table 14 shows the requirements for the command sequence.

During the unlock bypass mode, only the Unlock Bypass Program and Unlock Bypass Reset commands are valid. To exit the unlock bypass mode, the system must issue the two-cycle unlock bypass reset command sequence. The first cycle must contain the bank address and the data 90h. The second cycle need only contain the data 00h. The bank then returns to the read mode.

The device offers accelerated program operations through the WP#/ACC pin. When the system asserts V<sub>HH</sub> on the WP#/ACC pin, the device automatically enters the Unlock Bypass mode. The system may then write the two-cycle Unlock Bypass program command

sequence. The device uses the higher voltage on the WP#/ACC pin to accelerate the operation. Note that the WP#/ACC pin must not be at V<sub>HH</sub> any operation other than accelerated programming, or device damage may result. In addition, the WP#/ACC pin must not be left floating or unconnected; inconsistent behavior of the device may result.

Figure 3 illustrates the algorithm for the program operation. Refer to the Erase and Program Operations table in the AC Characteristics section for parameters, and Figure 17 for timing diagrams.

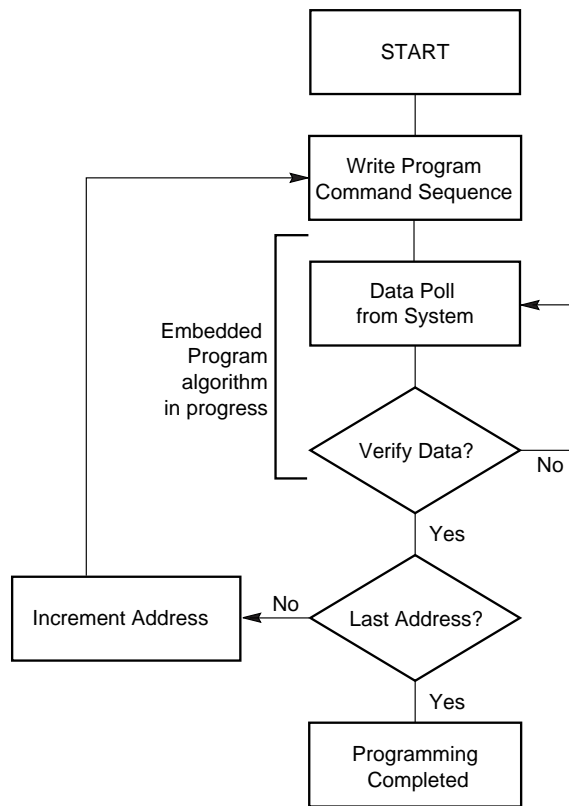

**Note:** See Table 14 for program command sequence.

**Figure 3. Program Operation**

**Chip Erase Command Sequence**

Chip erase is a six bus cycle operation. The chip erase command sequence is initiated by writing two unlock cycles, followed by a set-up command. Two additional unlock write cycles are then followed by the chip erase command, which in turn invokes the Embedded Erase algorithm. The device does *not* require the system to preprogram prior to erase. The Embedded Erase algorithm automatically preprograms and verifies the entire



memory for an all zero data pattern prior to electrical erase. The system is not required to provide any controls or timings during these operations. Table 14 shows the address and data requirements for the chip erase command sequence.

When the Embedded Erase algorithm is complete, that bank returns to the read mode and addresses are no longer latched. The system can determine the status of the erase operation by using DQ7, DQ6, DQ2, or RY/BY#. Refer to the Write Operation Status section for information on these status bits.

Any commands written during the chip erase operation are ignored. However, note that a **hardware reset** immediately terminates the erase operation. If that occurs, the chip erase command sequence should be reinitiated once that bank has returned to reading array data, to ensure data integrity.

Figure 4 illustrates the algorithm for the erase operation. Refer to the Erase and Program Operations tables in the AC Characteristics section for parameters, and Figure 19 section for timing diagrams.

### Sector Erase Command Sequence

Sector erase is a six bus cycle operation. The sector erase command sequence is initiated by writing two unlock cycles, followed by a set-up command. Two additional unlock cycles are written, and are then followed by the address of the sector to be erased, and the sector erase command. Table 14 shows the address and data requirements for the sector erase command sequence.

The device does *not* require the system to preprogram prior to erase. The Embedded Erase algorithm automatically programs and verifies the entire memory for an all zero data pattern prior to electrical erase. The system is not required to provide any controls or timings during these operations.

After the command sequence is written, a sector erase time-out of 50  $\mu$ s occurs. During the time-out period, additional sector addresses and sector erase commands (for sectors within the same bank) may be written. Loading the sector erase buffer may be done in any sequence, and the number of sectors may be from one sector to all sectors. The time between these additional cycles must be less than 50  $\mu$ s, otherwise erasure may begin. Any sector erase address and command following the exceeded time-out may or may not be accepted. It is recommended that processor interrupts be disabled during this time to ensure all commands are accepted. The interrupts can be re-enabled after the last Sector Erase command is written. **Any command other than Sector Erase or Erase Suspend during the time-out period resets that bank to the read mode.** The system must rewrite the com-

mand sequence and any additional addresses and commands.

The system can monitor DQ3 to determine if the sector erase timer has timed out (See the section on DQ3: Sector Erase Timer.). The time-out begins from the rising edge of the final WE# pulse in the command sequence.

When the Embedded Erase algorithm is complete, the bank returns to reading array data and addresses are no longer latched. Note that while the Embedded Erase operation is in progress, the system can read data from the non-erasing bank. The system can determine the status of the erase operation by reading DQ7, DQ6, DQ2, or RY/BY# in the erasing bank. Refer to the Write Operation Status section for information on these status bits.

Once the sector erase operation has begun, only the Erase Suspend command is valid. All other commands are ignored. However, note that a **hardware reset** immediately terminates the erase operation. If that occurs, the sector erase command sequence should be reinitiated once that bank has returned to reading array data, to ensure data integrity.

Figure 4 illustrates the algorithm for the erase operation. Refer to the Erase and Program Operations tables in the AC Characteristics section for parameters, and Figure 19 section for timing diagrams.

### Erase Suspend/Erase Resume Commands

The Erase Suspend command, B0h, allows the system to interrupt a sector erase operation and then read data from, or program data to, any sector not selected for erasure. The bank address is required when writing this command. This command is valid only during the sector erase operation, including the 50  $\mu$ s time-out period during the sector erase command sequence. The Erase Suspend command is ignored if written during the chip erase operation or Embedded Program algorithm.

When the Erase Suspend command is written during the sector erase operation, the device requires a maximum of 20  $\mu$ s to suspend the erase operation. However, when the Erase Suspend command is written during the sector erase time-out, the device immediately terminates the time-out period and suspends the erase operation.

After the erase operation has been suspended, the bank enters the erase-suspend-read mode. The system can read data from or program data to any sector not selected for erasure. (The device "erase suspends" all sectors selected for erasure.) Reading at any address within erase-suspended sectors produces status information on DQ7–DQ0. The system

can use DQ7, or DQ6 and DQ2 together, to determine if a sector is actively erasing or is erase-suspended. Refer to the Write Operation Status section for information on these status bits.

After an erase-suspended program operation is complete, the bank returns to the erase-suspend-read mode. The system can determine the status of the program operation using the DQ7 or DQ6 status bits, just as in the standard Byte Program operation. Refer to the Write Operation Status section for more information.

In the erase-suspend-read mode, the system can also issue the autoselect command sequence. Refer to the Autoselect Mode and Autoselect Command Sequence sections for details.

To resume the sector erase operation, the system must write the Erase Resume command. The bank address of the erase-suspended bank is required when writing this command. Further writes of the Resume command are ignored. Another Erase Suspend command can be written after the chip has resumed erasing.

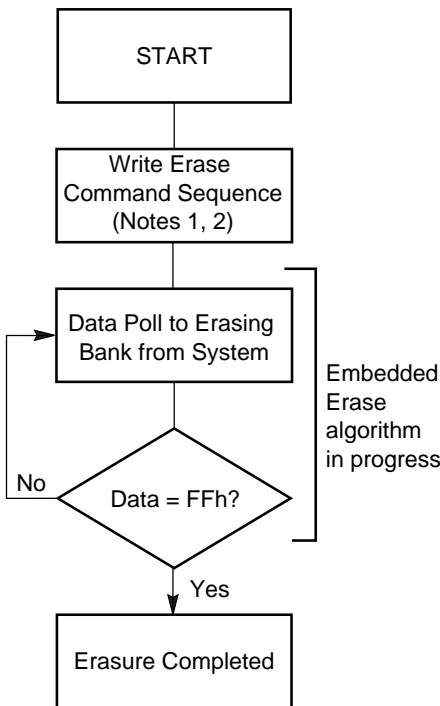

**Notes:**

1. See Table 14 for erase command sequence.
2. See the section on DQ3 for information on the sector erase timer.

**Figure 4. Erase Operation**

**Table 14. Command Definitions**

Command Sequence (Note 1)			Cycles	Bus Cycles (Notes 2–5)												
				First		Second		Third		Fourth		Fifth		Sixth		
				Addr	Data	Addr	Data	Addr	Data	Addr	Data	Addr	Data	Addr	Data	
Read (Note 6)			1	RA	RD											
Reset (Note 7)			1	XXX	F0											
Autoselect (Note 8)	Manufacturer ID	Word	4	555	AA	2AA	55	(BA)555	90	(BA)X00	01					
		Byte	4	AAA	AA	555	55	(BA)AAA	90	(BA)X01	(see Table 7)					
	Device ID	Word	4	555	AA	2AA	55	(BA)555	90	(BA)X02						
		Byte	4	AAA	AA	555	55	(BA)AAA	90	(BA)X03						
	SecSi™ Sector Factory Protect (Note 9)	Word	4	555	AA	2AA	55	(BA)555	90	(BA)X06	81/01					
		Byte	4	AAA	AA	555	55	(BA)AAA	90	(BA)X03						
	Sector/Sector Block Protect Verify (Note 10)	Word	4	555	AA	2AA	55	(BA)555	90	(SA)X02						
		Byte	4	AAA	AA	555	55	(BA)AAA	90	(SA)X04	00/01					
Enter SecSi Sector Region	Word	3	555	AA	2AA	55	555	88								
	Byte	3	AAA	AA	555	55	AAA	88								
Exit SecSi Sector Region	Word	4	555	AA	2AA	55	555	90	XXX	00						
	Byte	4	AAA	AA	555	55	AAA	90	XXX	00						
Program	Word	4	555	AA	2AA	55	555	A0	PA	PD						
	Byte	4	AAA	AA	555	55	AAA	A0	PA	PD						
Unlock Bypass	Word	3	555	AA	2AA	55	555	20								
	Byte	3	AAA	AA	555	55	AAA	20								
Unlock Bypass Program (Note 11)			2	XXX	A0	PA	PD									
Unlock Bypass Reset (Note 12)			2	BA	90	XXX	00									
Chip Erase	Word	6	555	AA	2AA	55	555	80	555	AA	2AA	55	555	10		
	Byte	6	AAA	AA	555	55	AAA	80	AAA	AA	555	55	AAA	10		
Sector Erase	Word	6	555	AA	2AA	55	555	80	555	AA	2AA	55	SA	30		
	Byte	6	AAA	AA	555	55	AAA	80	AAA	AA	555	55	SA	30		
Erase Suspend (Note 13)			1	BA	B0											
Erase Resume (Note 14)			1	BA	30											
CFI Query (Note 15)	Word	1	55	98												
	Byte	1	AA	98												

**Legend:**

X = Don't care

RA = Address of the memory location to be read.

RD = Data read from location RA during read operation.

PA = Address of the memory location to be programmed. Addresses latch on the falling edge of the WE# or CE# pulse, whichever happens later.

PD = Data to be programmed at location PA. Data latches on the rising edge of WE# or CE# pulse, whichever happens first.

SA = Address of the sector to be verified (in autoselect mode) or erased. Address bits A20–A12 uniquely select any sector.

BA = Address of the bank that is being switched to autoselect mode, is in bypass mode, or is being erased.

**Notes:**

- See Table 1 for description of bus operations.
- All values are in hexadecimal.
- Except for the read cycle and the fourth cycle of the autoselect command sequence, all bus cycles are write cycles.
- Data bits DQ15–DQ8 are don't care in command sequences, except for RD and PD.
- Unless otherwise noted, address bits A20–A11 are don't cares.
- No unlock or command cycles required when bank is reading array data.
- The Reset command is required to return to the read mode (or to the erase-suspend-read mode if previously in Erase Suspend) when a bank is in the autoselect mode, or if DQ5 goes high (while the bank is providing status information).
- The fourth cycle of the autoselect command sequence is a read cycle. The system must provide the bank address to obtain the manufacturer ID, device ID, or SecSi Sector factory protect information. Data bits DQ15–DQ8 are don't care. See the Autoselect Command Sequence section for more information.
- The data is 81h for factory locked and 01h for not factory locked.
- The data is 00h for an unprotected sector/sector block and 01h for a protected sector/sector block.
- The Unlock Bypass command is required prior to the Unlock Bypass Program command.
- The Unlock Bypass Reset command is required to return to the read mode when the bank is in the unlock bypass mode.
- The system may read and program in non-erasing sectors, or enter the autoselect mode, when in the Erase Suspend mode. The Erase Suspend command is valid only during a sector erase operation, and requires the bank address.
- The Erase Resume command is valid only during the Erase Suspend mode, and requires the bank address.
- Command is valid when device is ready to read array data or when device is in autoselect mode.

## WRITE OPERATION STATUS

The device provides several bits to determine the status of a program or erase operation: DQ2, DQ3, DQ5, DQ6, and DQ7. Table 15 and the following subsections describe the function of these bits. DQ7 and DQ6 each offer a method for determining whether a program or erase operation is complete or in progress. The device also provides a hardware-based output signal, RY/BY#, to determine whether an Embedded Program or Erase operation is in progress or has been completed.

### DQ7: Data# Polling

The Data# Polling bit, DQ7, indicates to the host system whether an Embedded Program or Erase algorithm is in progress or completed, or whether a bank is in Erase Suspend. Data# Polling is valid after the rising edge of the final WE# pulse in the command sequence.

During the Embedded Program algorithm, the device outputs on DQ7 the complement of the datum programmed to DQ7. This DQ7 status also applies to programming during Erase Suspend. When the Embedded Program algorithm is complete, the device outputs the datum programmed to DQ7. The system must provide the program address to read valid status information on DQ7. If a program address falls within a protected sector, Data# Polling on DQ7 is active for approximately 1  $\mu$ s, then that bank returns to the read mode.

During the Embedded Erase algorithm, Data# Polling produces a “0” on DQ7. When the Embedded Erase algorithm is complete, or if the bank enters the Erase Suspend mode, Data# Polling produces a “1” on DQ7. The system must provide an address within any of the sectors selected for erasure to read valid status information on DQ7.

After an erase command sequence is written, if all sectors selected for erasing are protected, Data# Polling on DQ7 is active for approximately 100  $\mu$ s, then the bank returns to the read mode. If not all selected sectors are protected, the Embedded Erase algorithm erases the unprotected sectors, and ignores the selected sectors that are protected. However, if the system reads DQ7 at an address within a protected sector, the status may not be valid.

Just prior to the completion of an Embedded Program or Erase operation, DQ7 may change asynchronously with DQ0–DQ6 while Output Enable (OE#) is asserted low. That is, the device may change from providing status information to valid data on DQ7. Depending on when the system samples the DQ7 output, it may read the status or valid data. Even if the device has completed the program or erase operation and DQ7 has valid data, the data outputs on DQ0–DQ6 may be still

invalid. Valid data on DQ0–DQ7 will appear on successive read cycles.

Table 15 shows the outputs for Data# Polling on DQ7. Figure 5 shows the Data# Polling algorithm. Figure 21 in the AC Characteristics section shows the Data# Polling timing diagram.

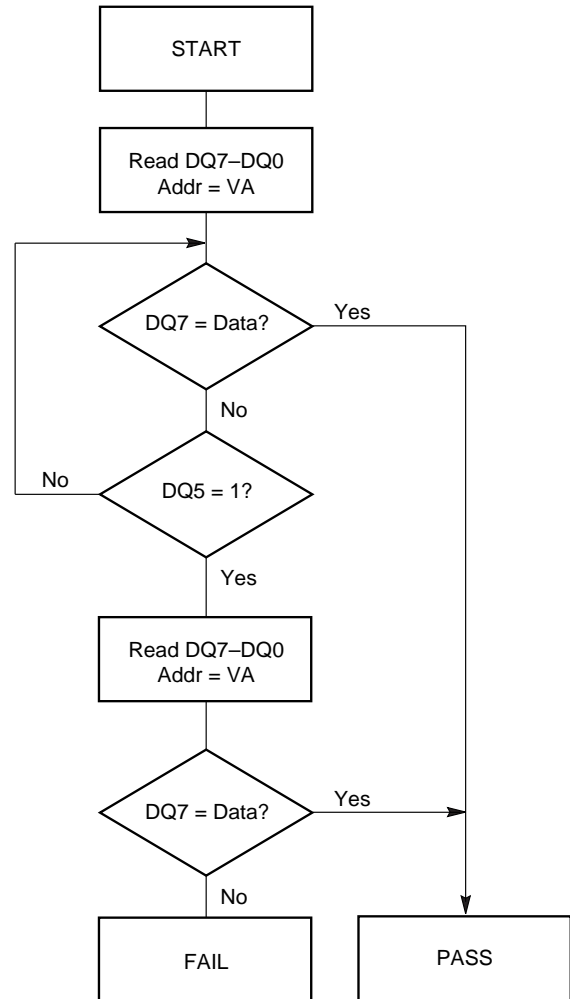

**Notes:**

1. VA = Valid address for programming. During a sector erase operation, a valid address is any sector address within the sector being erased. During chip erase, a valid address is any non-protected sector address.
2. DQ7 should be rechecked even if DQ5 = “1” because DQ7 may change simultaneously with DQ5.

**Figure 5. Data# Polling Algorithm**

## R<sub>Y</sub>/B<sub>Y</sub>#: Ready/Busy#

The R<sub>Y</sub>/B<sub>Y</sub># is a dedicated, open-drain output pin which indicates whether an Embedded Algorithm is in progress or complete. The R<sub>Y</sub>/B<sub>Y</sub># status is valid after the rising edge of the final WE# pulse in the command sequence. Since R<sub>Y</sub>/B<sub>Y</sub># is an open-drain output, several R<sub>Y</sub>/B<sub>Y</sub># pins can be tied together in parallel with a pull-up resistor to V<sub>CC</sub>.

If the output is low (Busy), the device is actively erasing or programming. (This includes programming in the Erase Suspend mode.) If the output is high (Ready), the device is in the read mode, the standby mode, or one of the banks is in the erase-suspend-read mode.

Table 15 shows the outputs for R<sub>Y</sub>/B<sub>Y</sub>#.

## DQ6: Toggle Bit I

Toggle Bit I on DQ6 indicates whether an Embedded Program or Erase algorithm is in progress or complete, or whether the device has entered the Erase Suspend mode. Toggle Bit I may be read at any address, and is valid after the rising edge of the final WE# pulse in the command sequence (prior to the program or erase operation), and during the sector erase time-out.

During an Embedded Program or Erase algorithm operation, successive read cycles to any address cause DQ6 to toggle. The system may use either OE# or CE# to control the read cycles. When the operation is complete, DQ6 stops toggling.

After an erase command sequence is written, if all sectors selected for erasing are protected, DQ6 toggles for approximately 100 μs, then returns to reading array data. If not all selected sectors are protected, the Embedded Erase algorithm erases the unprotected sectors, and ignores the selected sectors that are protected.

The system can use DQ6 and DQ2 together to determine whether a sector is actively erasing or is erase-suspended. When the device is actively erasing (that is, the Embedded Erase algorithm is in progress), DQ6 toggles. When the device enters the Erase Suspend mode, DQ6 stops toggling. However, the system must also use DQ2 to determine which sectors are erasing or erase-suspended. Alternatively, the system can use DQ7 (see the subsection on DQ7: Data# Polling).

If a program address falls within a protected sector, DQ6 toggles for approximately 1 μs after the program command sequence is written, then returns to reading array data.

DQ6 also toggles during the erase-suspend-program mode, and stops toggling once the Embedded Program algorithm is complete.

Table 15 shows the outputs for Toggle Bit I on DQ6. Figure 6 shows the toggle bit algorithm. Figure 22 in the “AC Characteristics” section shows the toggle bit timing diagrams. Figure 23 shows the differences between DQ2 and DQ6 in graphical form. See also the subsection on DQ2: Toggle Bit II.

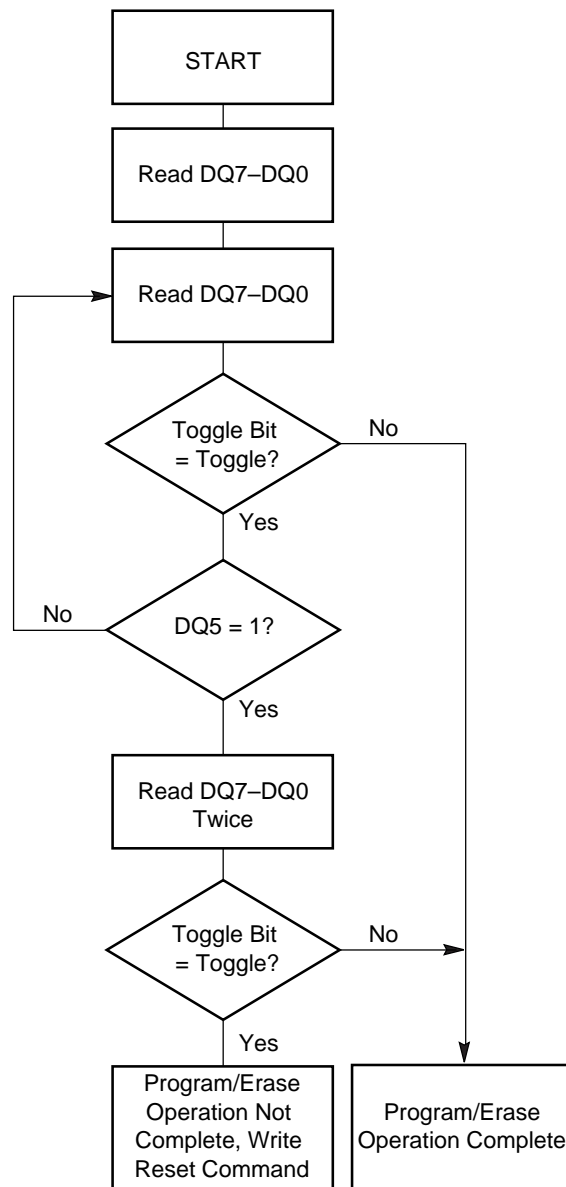

**Note:** The system should recheck the toggle bit even if DQ5 = “1” because the toggle bit may stop toggling as DQ5 changes to “1.” See the subsections on DQ6 and DQ2 for more information.

**Figure 6. Toggle Bit Algorithm**

## DQ2: Toggle Bit II

The “Toggle Bit II” on DQ2, when used with DQ6, indicates whether a particular sector is actively erasing (that is, the Embedded Erase algorithm is in progress), or whether that sector is erase-suspended. Toggle Bit II is valid after the rising edge of the final WE# pulse in the command sequence.

DQ2 toggles when the system reads at addresses within those sectors that have been selected for erasure. (The system may use either OE# or CE# to control the read cycles.) But DQ2 cannot distinguish whether the sector is actively erasing or is erase-suspended. DQ6, by comparison, indicates whether the device is actively erasing, or is in Erase Suspend, but cannot distinguish which sectors are selected for erasure. Thus, both status bits are required for sector and mode information. Refer to Table 15 to compare outputs for DQ2 and DQ6.

Figure 6 shows the toggle bit algorithm in flowchart form, and the section “DQ2: Toggle Bit II” explains the algorithm. See also the DQ6: Toggle Bit I subsection. Figure 22 shows the toggle bit timing diagram. Figure 23 shows the differences between DQ2 and DQ6 in graphical form.

## Reading Toggle Bits DQ6/DQ2

Refer to Figure 6 for the following discussion. Whenever the system initially begins reading toggle bit status, it must read DQ7–DQ0 at least twice in a row to determine whether a toggle bit is toggling. Typically, the system would note and store the value of the toggle bit after the first read. After the second read, the system would compare the new value of the toggle bit with the first. If the toggle bit is not toggling, the device has completed the program or erase operation. The system can read array data on DQ7–DQ0 on the following read cycle.

However, if after the initial two read cycles, the system determines that the toggle bit is still toggling, the system also should note whether the value of DQ5 is high (see the section on DQ5). If it is, the system should then determine again whether the toggle bit is toggling, since the toggle bit may have stopped toggling just as DQ5 went high. If the toggle bit is no longer toggling, the device has successfully completed the program or erase operation. If it is still toggling, the device did not complete the operation successfully, and the system must write the reset command to return to reading array data.

The remaining scenario is that the system initially determines that the toggle bit is toggling and DQ5 has not gone high. The system may continue to monitor

the toggle bit and DQ5 through successive read cycles, determining the status as described in the previous paragraph. Alternatively, it may choose to perform other system tasks. In this case, the system must start at the beginning of the algorithm when it returns to determine the status of the operation (top of Figure 6).

## DQ5: Exceeded Timing Limits

DQ5 indicates whether the program or erase time has exceeded a specified internal pulse count limit. Under these conditions DQ5 produces a “1,” indicating that the program or erase cycle was not successfully completed.

The device may output a “1” on DQ5 if the system tries to program a “1” to a location that was previously programmed to “0.” **Only an erase operation can change a “0” back to a “1.”** Under this condition, the device halts the operation, and when the timing limit has been exceeded, DQ5 produces a “1.”

Under both these conditions, the system must write the reset command to return to the read mode (or to the erase-suspend-read mode if a bank was previously in the erase-suspend-program mode).

## DQ3: Sector Erase Timer

After writing a sector erase command sequence, the system may read DQ3 to determine whether or not erasure has begun. (The sector erase timer does not apply to the chip erase command.) If additional sectors are selected for erasure, the entire time-out also applies after each additional sector erase command. When the time-out period is complete, DQ3 switches from a “0” to a “1.” If the time between additional sector erase commands from the system can be assumed to be less than 50  $\mu$ s, the system need not monitor DQ3. See also the Sector Erase Command Sequence section.

After the sector erase command is written, the system should read the status of DQ7 (Data# Polling) or DQ6 (Toggle Bit I) to ensure that the device has accepted the command sequence, and then read DQ3. If DQ3 is “1,” the Embedded Erase algorithm has begun; all further commands (except Erase Suspend) are ignored until the erase operation is complete. If DQ3 is “0,” the device will accept additional sector erase commands. To ensure the command has been accepted, the system software should check the status of DQ3 prior to and following each subsequent sector erase command. If DQ3 is high on the second status check, the last command might not have been accepted.

Table 15 shows the status of DQ3 relative to the other status bits.

Table 15. Write Operation Status

Status		DQ7 (Note 2)	DQ6	DQ5 (Note 1)	DQ3	DQ2 (Note 2)	RY/BY#	
Standard Mode	Embedded Program Algorithm	DQ7#	Toggle	0	N/A	No toggle	0	
	Embedded Erase Algorithm	0	Toggle	0	1	Toggle	0	
Erase Suspend Mode	Erase-Suspend-Read	Erase Suspended Sector	1	No toggle	0	N/A	Toggle	1
		Non-Erase Suspended Sector	Data	Data	Data	Data	Data	1
	Erase-Suspend-Program	DQ7#	Toggle	0	N/A	N/A	0	

**Notes:**

1. DQ5 switches to '1' when an Embedded Program or Embedded Erase operation has exceeded the maximum timing limits. Refer to the section on DQ5 for more information.
2. DQ7 and DQ2 require a valid address when reading status information. Refer to the appropriate subsection for further details.
3. When reading write operation status bits, the system must always provide the bank address where the Embedded Algorithm is in progress. The device outputs array data if the system addresses a non-busy bank.

**ABSOLUTE MAXIMUM RATINGS**

Storage Temperature  
 Plastic Packages . . . . . -65°C to +150°C

Ambient Temperature  
 with Power Applied. . . . . -65°C to +125°C

Voltage with Respect to Ground

$V_{CC}$  (Note 1) . . . . . -0.5 V to +4.0 V

A9, OE#, and RESET#  
 (Note 2). . . . . -0.5 V to +12.5 V

WP#/ACC . . . . . -0.5 V to +10.5 V

All other pins (Note 1) . . . . . -0.5 V to  $V_{CC} + 0.5$  V

Output Short Circuit Current (Note 3) . . . . . 200 mA

**Notes:**

1. Minimum DC voltage on input or I/O pins is -0.5 V. During voltage transitions, input or I/O pins may overshoot  $V_{SS}$  to -2.0 V for periods of up to 20 ns. Maximum DC voltage on input or I/O pins is  $V_{CC} + 0.5$  V. See Figure 7. During voltage transitions, input or I/O pins may overshoot to  $V_{CC} + 2.0$  V for periods up to 20 ns. See Figure 8.
2. Minimum DC input voltage on pins A9, OE#, RESET#, and WP#/ACC is -0.5 V. During voltage transitions, A9, OE#, WP#/ACC, and RESET# may overshoot  $V_{SS}$  to -2.0 V for periods of up to 20 ns. See Figure 7. Maximum DC input voltage on pin A9 is +12.5 V which may overshoot to +14.0 V for periods up to 20 ns. Maximum DC input voltage on WP#/ACC is +9.5 V which may overshoot to +12.0 V for periods up to 20 ns.
3. No more than one output may be shorted to ground at a time. Duration of the short circuit should not be greater than one second.

Stresses above those listed under "Absolute Maximum Ratings" may cause permanent damage to the device. This is a stress rating only; functional operation of the device at these or any other conditions above those indicated in the operational sections of this data sheet is not implied. Exposure of the device to absolute maximum rating conditions for extended periods may affect device reliability.

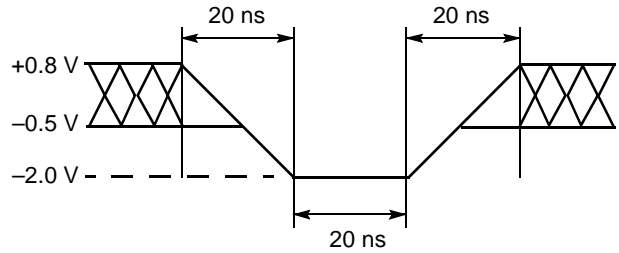

**Figure 7. Maximum Negative Overshoot Waveform**

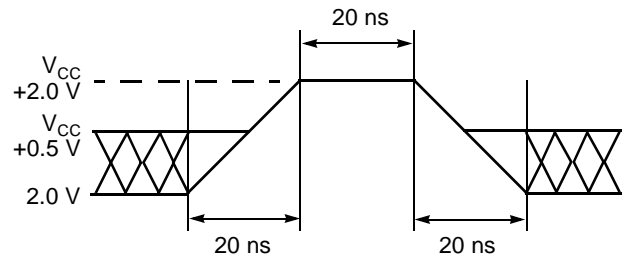

**Figure 8. Maximum Positive Overshoot Waveform**

**OPERATING RANGES**

**Industrial (I) Devices**

Ambient Temperature ( $T_A$ ) . . . . . -40°C to +85°C

**Extended (E) Devices**

Ambient Temperature ( $T_A$ ) . . . . . -55°C to +125°C

**$V_{CC}$  Supply Voltages**

$V_{CC}$  for regulated voltage range . . . . . 3.0 V to 3.6 V

$V_{CC}$  for standard voltage range . . . . . 2.7 V to 3.6 V

Operating ranges define those limits between which the functionality of the device is guaranteed.



## DC CHARACTERISTICS

## CMOS Compatible

Parameter Symbol	Parameter Description	Test Conditions	Min	Typ	Max	Unit
$I_{LI}$	Input Load Current	$V_{IN} = V_{SS}$ to $V_{CC}$ , $V_{CC} = V_{CC\ max}$			$\pm 1.0$	$\mu A$
$I_{LIT}$	A9 Input Load Current	$V_{CC} = V_{CC\ max}$ ; A9 = 12.5 V			35	$\mu A$
$I_{LO}$	Output Leakage Current	$V_{OUT} = V_{SS}$ to $V_{CC}$ , $V_{CC} = V_{CC\ max}$			$\pm 1.0$	$\mu A$
$I_{CC1}$	$V_{CC}$ Active Read Current (Notes 1, 2)	CE# = $V_{IL}$ , OE# = $V_{IH}$ , Byte Mode	5 MHz	10	16	mA
			1 MHz	2	4	
		CE# = $V_{IL}$ , OE# = $V_{IH}$ , Word Mode	5 MHz	10	16	
			1 MHz	2	4	
$I_{CC2}$	$V_{CC}$ Active Write Current (Notes 2, 3)	CE# = $V_{IL}$ , OE# = $V_{IH}$ , WE# = $V_{IL}$		15	30	mA
$I_{CC3}$	$V_{CC}$ Standby Current (Note 2)	CE#, RESET# = $V_{CC} \pm 0.3$ V		0.2	5	$\mu A$
$I_{CC4}$	$V_{CC}$ Reset Current (Note 2)	RESET# = $V_{SS} \pm 0.3$ V		0.2	5	$\mu A$
$I_{CC5}$	Automatic Sleep Mode (Notes 2, 4)	$V_{IH} = V_{CC} \pm 0.3$ V; $V_{IL} = V_{SS} \pm 0.3$ V		0.2	5	$\mu A$
$I_{CC6}$	$V_{CC}$ Active Read-While-Program Current (Notes 1, 2)	CE# = $V_{IL}$ , OE# = $V_{IH}$	Byte	21	45	mA
			Word	21	45	
$I_{CC7}$	$V_{CC}$ Active Read-While-Erase Current (Notes 1, 2)	CE# = $V_{IL}$ , OE# = $V_{IH}$	Byte	21	45	mA
			Word	21	45	
$I_{CC8}$	$V_{CC}$ Active Program-While-Erase-Suspended Current (Notes 2, 5)	CE# = $V_{IL}$ , OE# = $V_{IH}$		17	35	mA
$I_{ACC}$	ACC Accelerated Program Current, Word or Byte	CE# = $V_{IL}$ , OE# = $V_{IH}$	ACC pin	5	10	mA
			$V_{CC}$ pin	15	30	mA
$V_{IL}$	Input Low Voltage		-0.5		0.8	V
$V_{IH}$	Input High Voltage		$0.7 \times V_{CC}$		$V_{CC} + 0.3$	V
$V_{HH}$	Voltage for WP#/ACC Sector Protect/Unprotect and Program Acceleration	$V_{CC} = 3.0$ V $\pm$ 10%	8.5		9.5	V
$V_{ID}$	Voltage for Autoselect and Temporary Sector Unprotect	$V_{CC} = 3.0$ V $\pm$ 10%	8.5		12.5	V
$V_{OL}$	Output Low Voltage	$I_{OL} = 4.0$ mA, $V_{CC} = V_{CC\ min}$			0.45	V
$V_{OH1}$	Output High Voltage	$I_{OH} = -2.0$ mA, $V_{CC} = V_{CC\ min}$	$0.85 V_{CC}$			V
$V_{OH2}$		$I_{OH} = -100$ $\mu A$ , $V_{CC} = V_{CC\ min}$	$V_{CC} - 0.4$			
$V_{LKO}$	Low $V_{CC}$ Lock-Out Voltage (Note 5)		2.3		2.5	V

**Notes:**

1. The  $I_{CC}$  current listed is typically less than 2 mA/MHz, with OE# at  $V_{IH}$ .
2. Maximum  $I_{CC}$  specifications are tested with  $V_{CC} = V_{CC\ max}$ .
3.  $I_{CC}$  active while Embedded Erase or Embedded Program is in progress.
4. Automatic sleep mode enables the low power mode when addresses remain stable for  $t_{ACC} + 30$  ns. Typical sleep mode current is 200 nA.
5. Not 100% tested.

DC CHARACTERISTICS

Zero-Power Flash

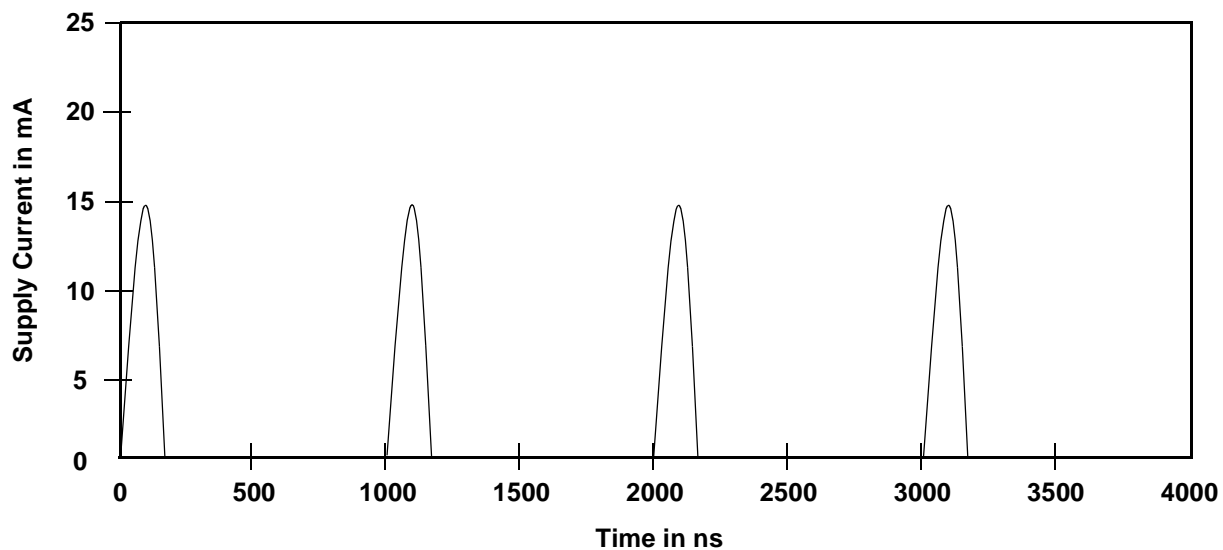

Note: Addresses are switching at 1 MHz

Figure 9.  $I_{CC1}$  Current vs. Time (Showing Active and Automatic Sleep Currents)

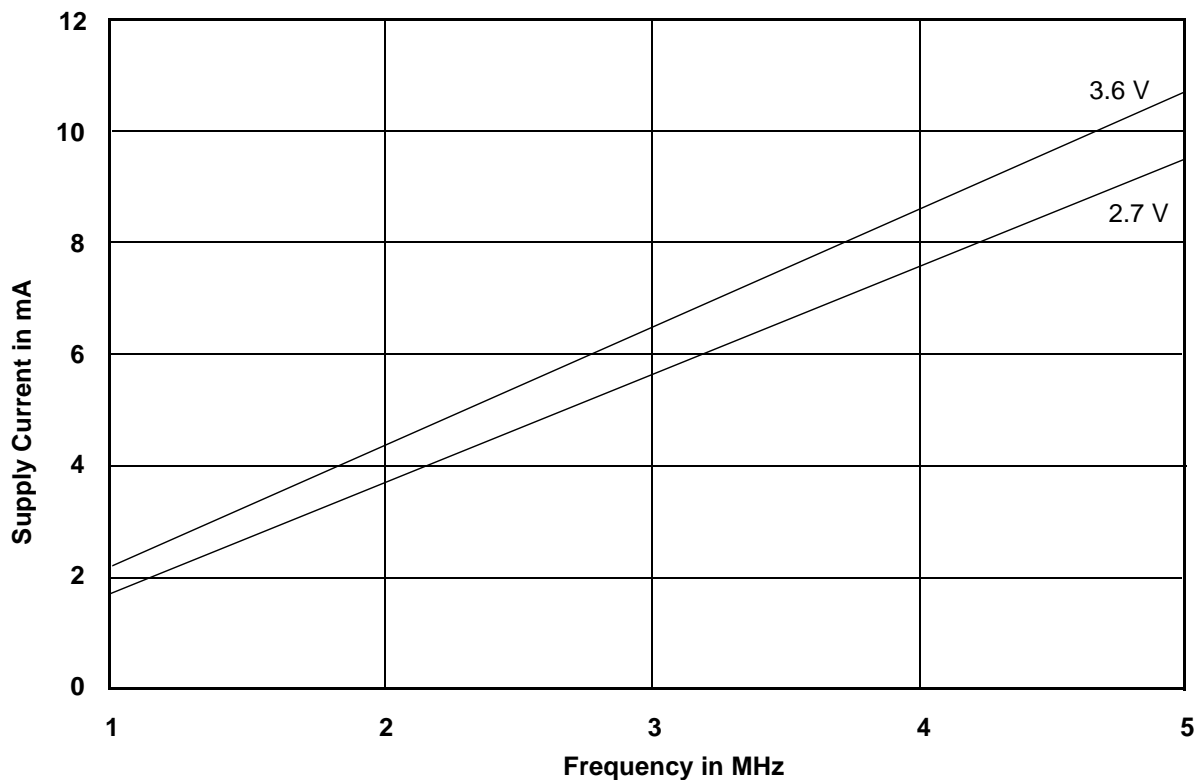

Note:  $T = 25^{\circ}\text{C}$

Figure 10. Typical  $I_{CC1}$  vs. Frequency

**TEST CONDITIONS**

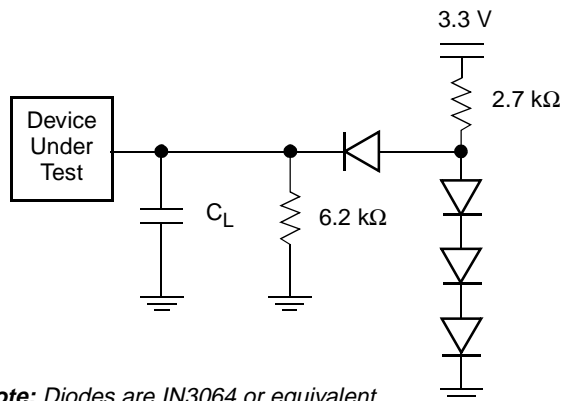

*Note: Diodes are IN3064 or equivalent*

**Figure 11. Test Setup**

**Table 16. Test Specifications**

Test Condition	70R, 90	120	Unit
Output Load	1 TTL gate		
Output Load Capacitance, C <sub>L</sub> (including jig capacitance)	30	100	pF
Input Rise and Fall Times	5		ns
Input Pulse Levels	0.0–3.0		V
Input timing measurement reference levels	1.5		V
Output timing measurement reference levels	1.5		V

**KEY TO SWITCHING WAVEFORMS**

WAVEFORM	INPUTS	OUTPUTS
	Steady	
	Changing from H to L	
	Changing from L to H	
	Don't Care, Any Change Permitted	Changing, State Unknown
	Does Not Apply	Center Line is High Impedance State (High Z)

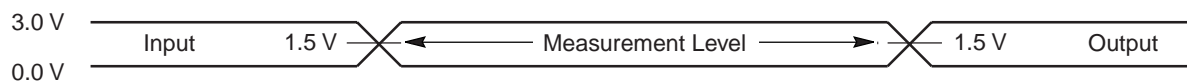

**Figure 12. Input Waveforms and Measurement Levels**

## AC CHARACTERISTICS

### Read-Only Operations

Parameter		Description	Test Setup		Speed Options			Unit
JEDEC	Std.				70R	90	120	
$t_{AVAV}$	$t_{RC}$	Read Cycle Time (Note 1)		Min	70	90	120	ns
$t_{AVQV}$	$t_{ACC}$	Address to Output Delay	CE#, OE# = $V_{IL}$	Max	70	90	120	ns
$t_{ELQV}$	$t_{CE}$	Chip Enable to Output Delay	OE# = $V_{IL}$	Max	70	90	120	ns
$t_{GLQV}$	$t_{OE}$	Output Enable to Output Delay		Max	30	40	50	ns
$t_{EHQZ}$	$t_{DF}$	Chip Enable to Output High Z (Note 1)		Max	16			ns
$t_{GHQZ}$	$t_{DF}$	Output Enable to Output High Z (Note 1)		Max	16			ns
$t_{AXQX}$	$t_{OH}$	Output Hold Time From Addresses, CE# or OE#, Whichever Occurs First		Min	0			ns
	$t_{OEh}$	Output Enable Hold Time (Note 1)	Read	Min	0			ns
			Toggle and Data# Polling	Min	10			ns

**Notes:**

1. Not 100% tested.
2. See Figure 11 and Table 16 for test specifications.

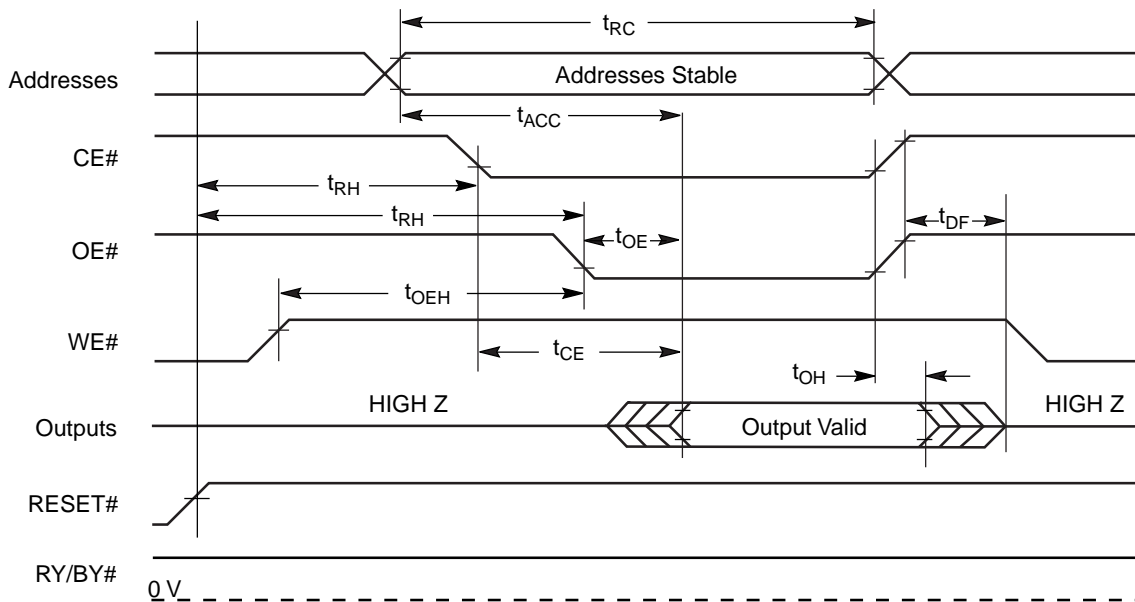

Figure 13. Read Operation Timings

## AC CHARACTERISTICS

### Hardware Reset (RESET#)

Parameter		Description		All Speed Options	Unit
JEDEC	Std				
	$t_{Ready}$	RESET# Pin Low (During Embedded Algorithms) to Read Mode (See Note)	Max	20	$\mu s$
	$t_{Ready}$	RESET# Pin Low (NOT During Embedded Algorithms) to Read Mode (See Note)	Max	500	ns
	$t_{RP}$	RESET# Pulse Width	Min	500	ns
	$t_{RH}$	Reset High Time Before Read (See Note)	Min	50	ns
	$t_{RPD}$	RESET# Low to Standby Mode	Min	20	$\mu s$
	$t_{RB}$	RY/BY# Recovery Time	Min	0	ns

**Note:** Not 100% tested.

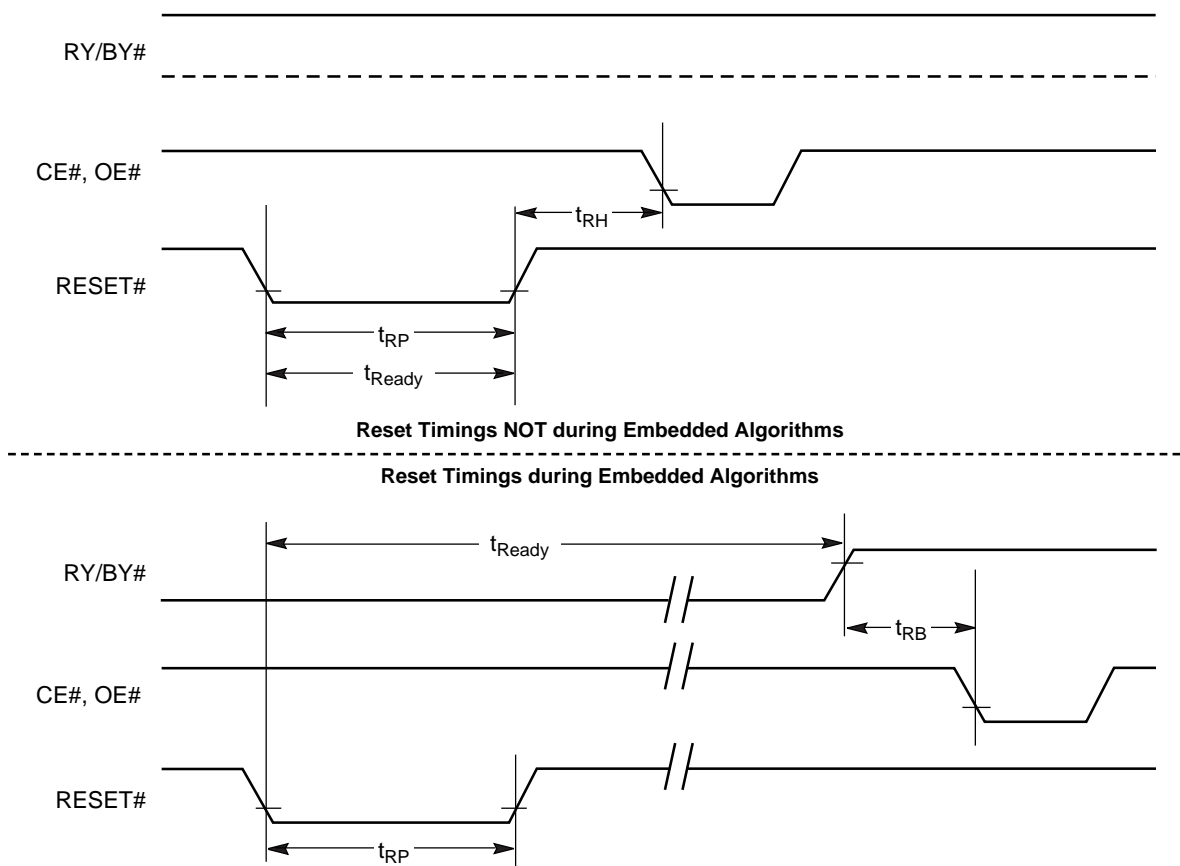

Figure 14. Reset Timings

AC CHARACTERISTICS

Word/Byte Configuration (BYTE#)

Parameter		Description		Speed Options			Unit
JEDEC	Std			70R	90	120	
	$t_{ELFL}/t_{ELFH}$	CE# to BYTE# Switching Low or High	Max	70	5		ns
	$t_{FLQZ}$	BYTE# Switching Low to Output HIGH Z	Max	16			ns
	$t_{FHQV}$	BYTE# Switching High to Output Active	Min	70	90	120	ns

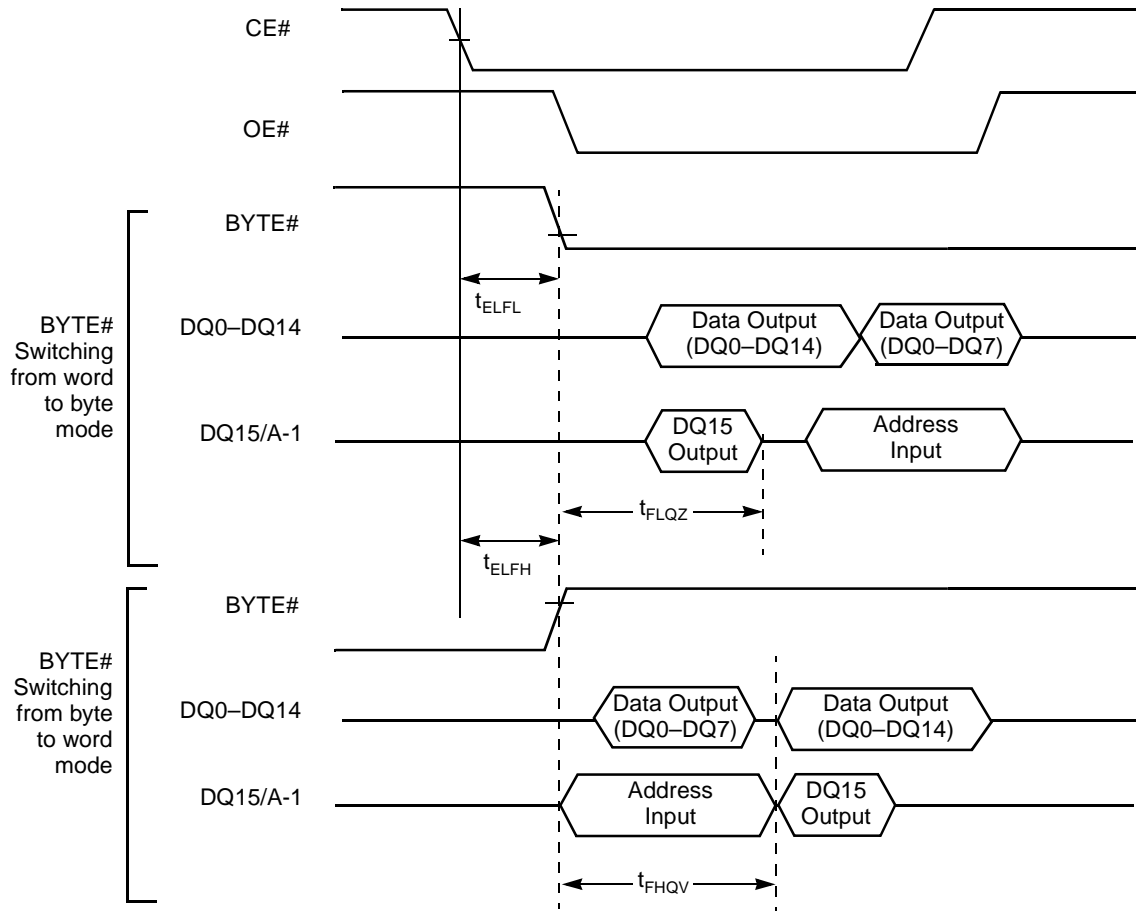
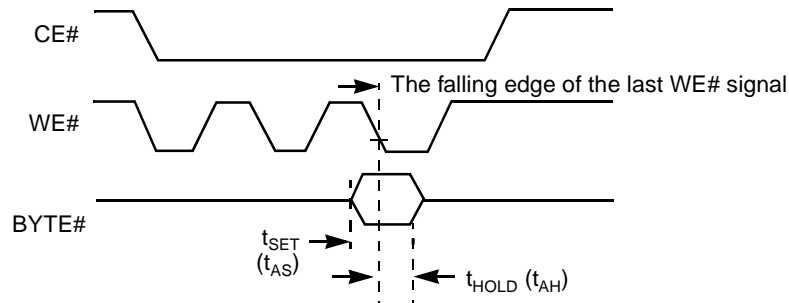

Figure 15. BYTE# Timings for Read Operations



Note: Refer to the Erase/Program Operations table for  $t_{AS}$  and  $t_{AH}$  specifications.

Figure 16. BYTE# Timings for Write Operations

## AC CHARACTERISTICS

## Erase and Program Operations

Parameter		Description		Speed Options			Unit
JEDEC	Std			70R	90	120	
$t_{AVAV}$	$t_{WC}$	Write Cycle Time (Note 1)	Min	70	90	120	ns
$t_{AVWL}$	$t_{AS}$	Address Setup Time	Min	0			ns
	$t_{ASO}$	Address Setup Time to OE# low during toggle bit polling	Min	15	15		ns
$t_{WLAX}$	$t_{AH}$	Address Hold Time	Min	45	45	50	ns
	$t_{AHT}$	Address Hold Time From CE# or OE# high during toggle bit polling	Min	0			ns
$t_{DVWH}$	$t_{DS}$	Data Setup Time	Min	35	45	50	ns
$t_{WHDX}$	$t_{DH}$	Data Hold Time	Min	0			ns
	$t_{OEPH}$	Output Enable High during toggle bit polling	Min	20			ns
$t_{GHWL}$	$t_{GHWL}$	Read Recovery Time Before Write (OE# High to WE# Low)	Min	0			ns
$t_{ELWL}$	$t_{CS}$	CE# Setup Time	Min	0			ns
$t_{WHEH}$	$t_{CH}$	CE# Hold Time	Min	0			ns
$t_{WLWH}$	$t_{WP}$	Write Pulse Width	Min	30	35	50	ns
$t_{WHDL}$	$t_{WPH}$	Write Pulse Width High	Min	30			ns
	$t_{SR/W}$	Latency Between Read and Write Operations	Min	0			ns
$t_{WHWH1}$	$t_{WHWH1}$	Programming Operation (Note 2)	Byte	Typ			$\mu$ s
			Word	Typ			
$t_{WHWH1}$	$t_{WHWH1}$	Accelerated Programming Operation, Word or Byte (Note 2)	Typ	4			$\mu$ s
$t_{WHWH2}$	$t_{WHWH2}$	Sector Erase Operation (Note 2)	Typ	0.7			sec
	$t_{VCS}$	$V_{CC}$ Setup Time (Note 1)	Min	50			$\mu$ s
	$t_{RB}$	Write Recovery Time from RY/BY#	Min	0			ns
	$t_{BUSY}$	Program/Erase Valid to RY/BY# Delay	Min	90			ns

**Notes:**

1. Not 100% tested.
2. See the "Erase And Programming Performance" section for more information.

AC CHARACTERISTICS

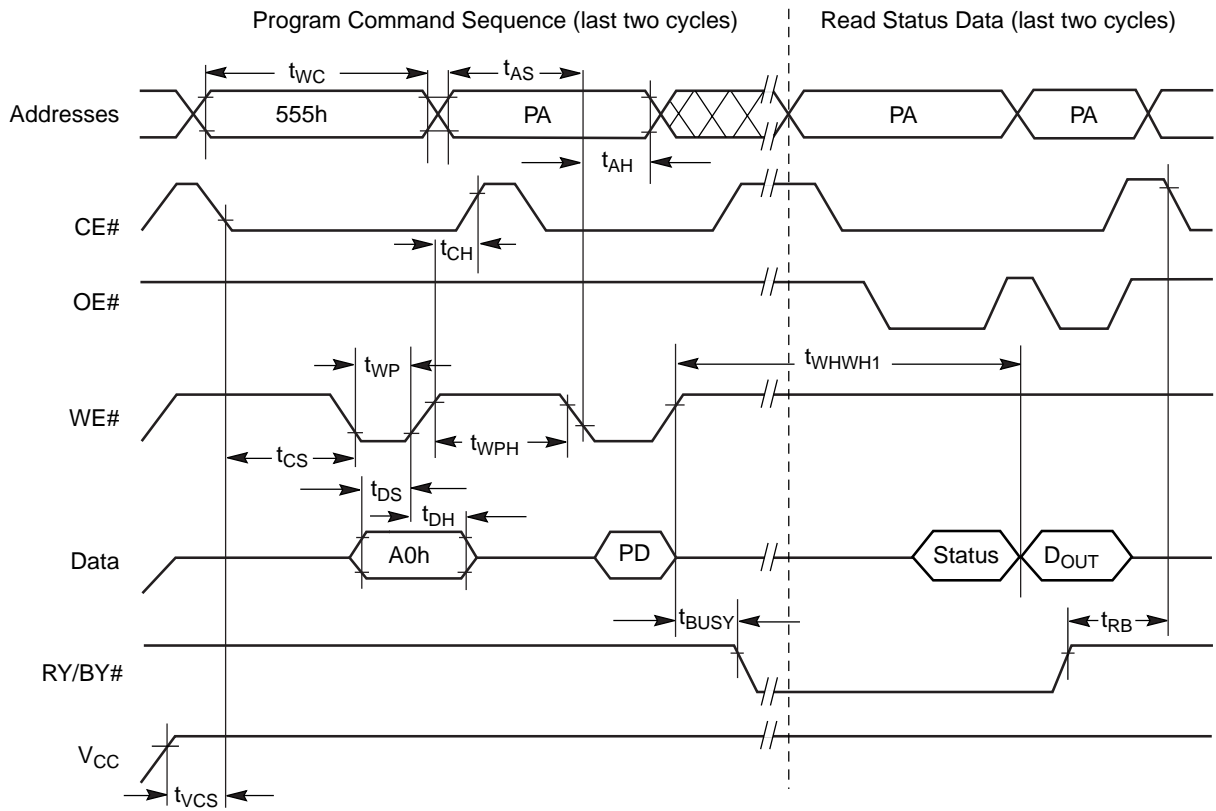

Notes:

1. PA = program address, PD = program data, D<sub>OUT</sub> is the true data at the program address.
2. Illustration shows device in word mode.

Figure 17. Program Operation Timings

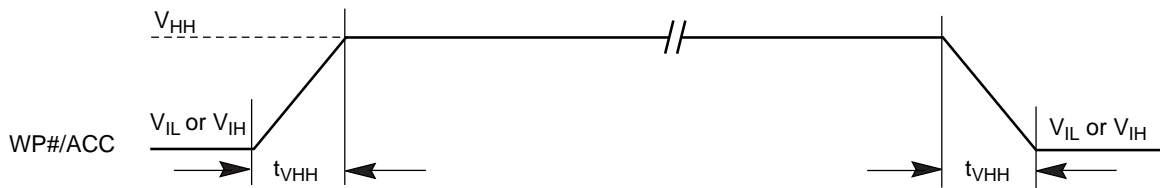
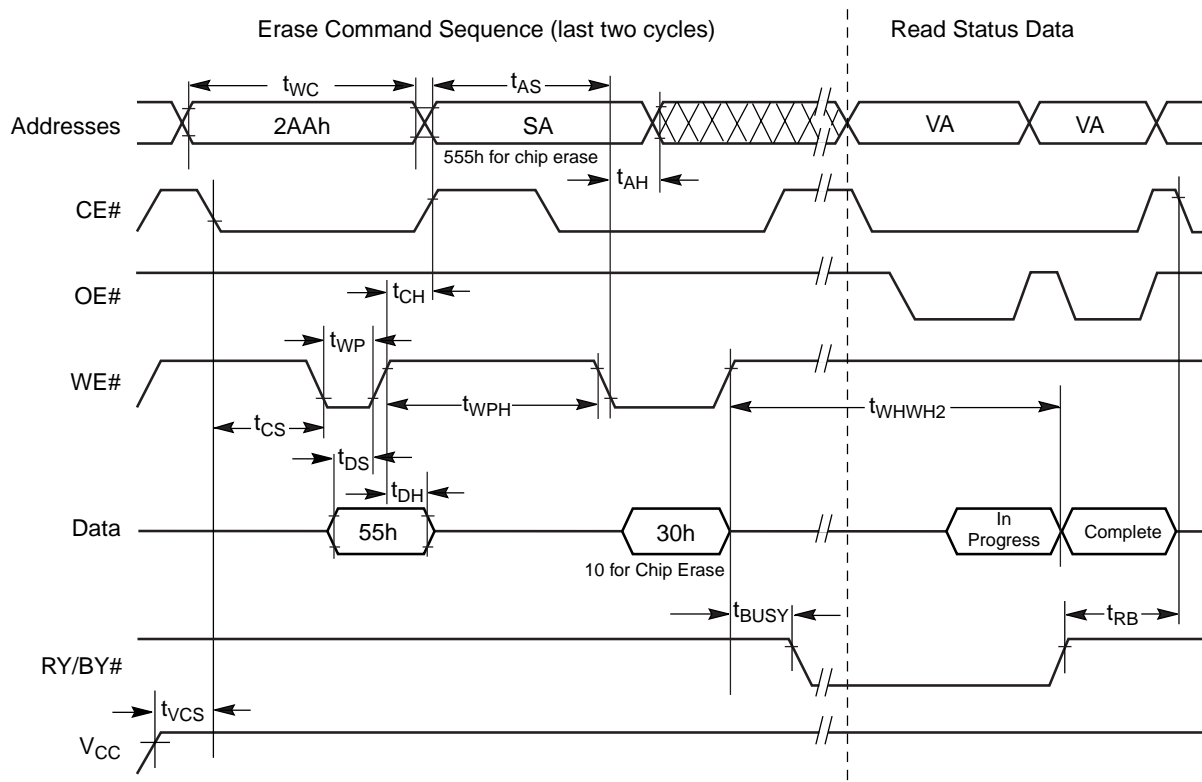

Figure 18. Accelerated Program Timing Diagram



AC CHARACTERISTICS



Notes:

1. SA = sector address (for Sector Erase), VA = Valid Address for reading status data (see "Write Operation Status").
2. These waveforms are for the word mode.

Figure 19. Chip/Sector Erase Operation Timings

AC CHARACTERISTICS

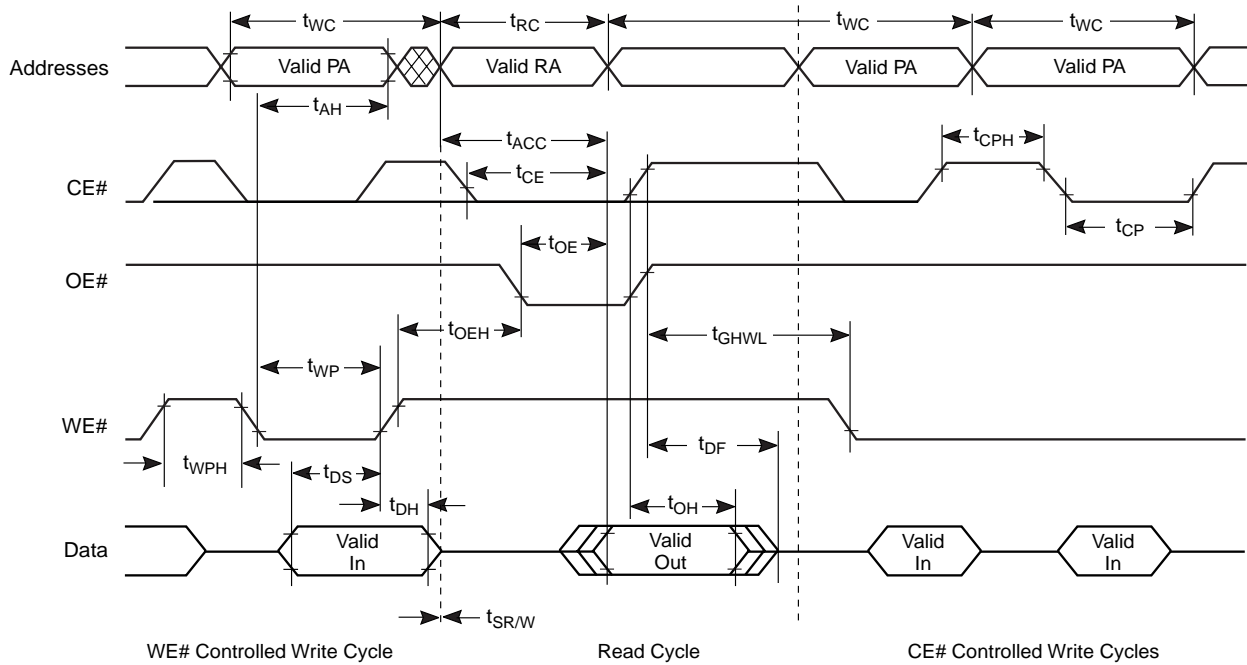
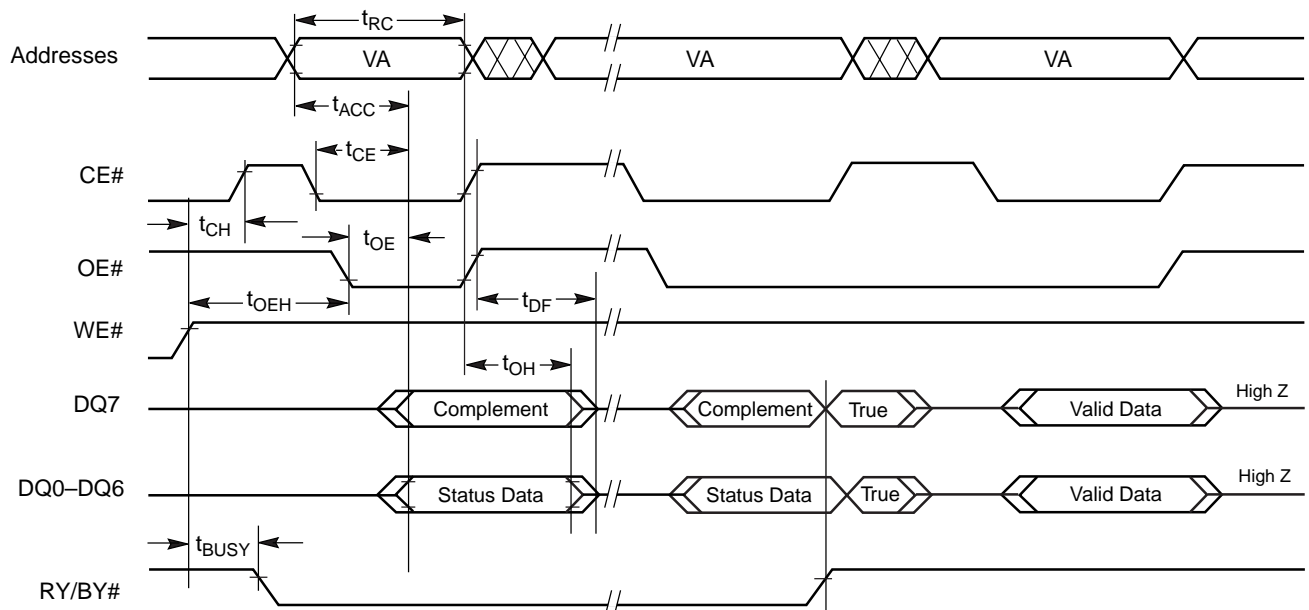

Figure 20. Back-to-back Read/Write Cycle Timings



**Note:** VA = Valid address. Illustration shows first status cycle after command sequence, last status read cycle, and array data read cycle.

Figure 21. Data# Polling Timings (During Embedded Algorithms)

## AC CHARACTERISTICS

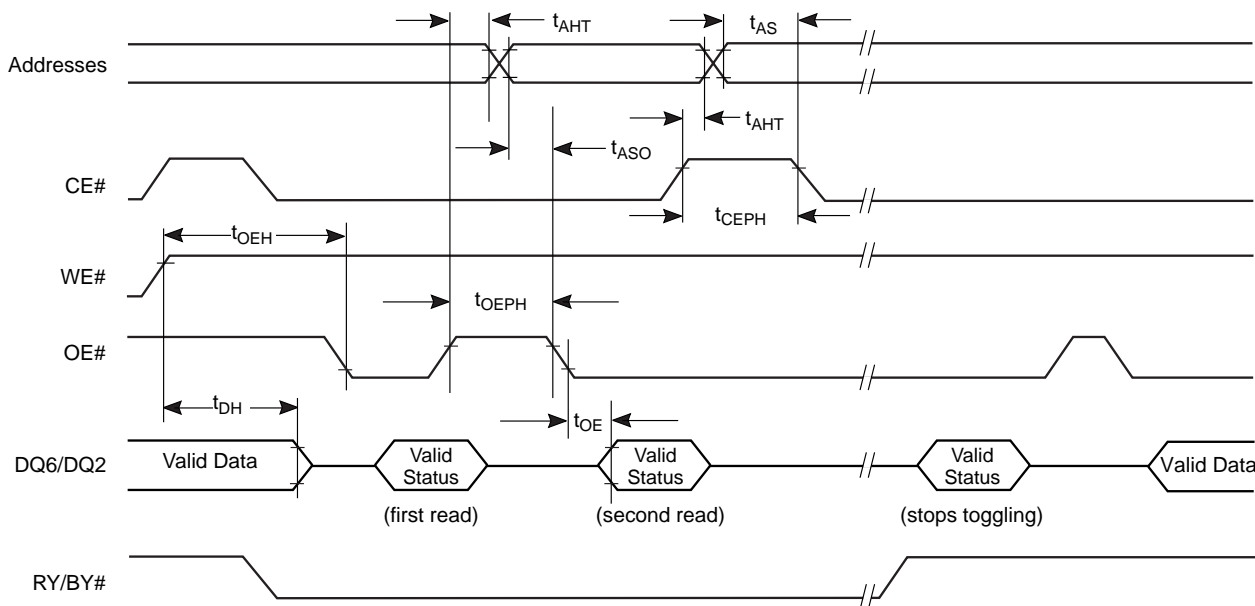

**Note:** VA = Valid address; not required for DQ6. Illustration shows first two status cycle after command sequence, last status read cycle, and array data read cycle

**Figure 22. Toggle Bit Timings (During Embedded Algorithms)**

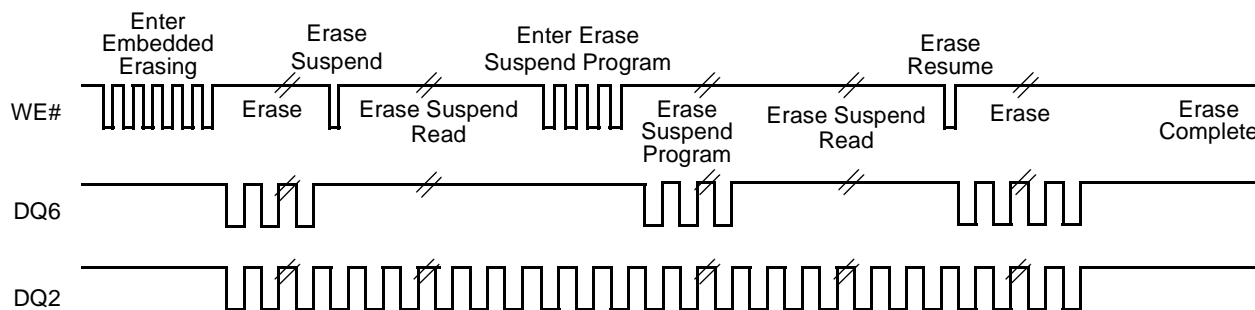

**Note:** DQ2 toggles only when read at an address within an erase-suspended sector. The system may use OE# or CE# to toggle DQ2 and DQ6.

**Figure 23. DQ2 vs. DQ6**

## AC CHARACTERISTICS

### Temporary Sector Unprotect

Parameter		Description		All Speed Options	Unit
JEDEC	Std				
	$t_{VIDR}$	$V_{ID}$ Rise and Fall Time (See Note)	Min	500	ns
	$t_{VHH}$	$V_{HH}$ Rise and Fall Time (See Note)	Min	250	ns
	$t_{RSP}$	RESET# Setup Time for Temporary Sector Unprotect	Min	4	$\mu$ s
	$t_{RRB}$	RESET# Hold Time from RY/BY# High for Temporary Sector Unprotect	Min	4	$\mu$ s

**Note:** Not 100% tested.

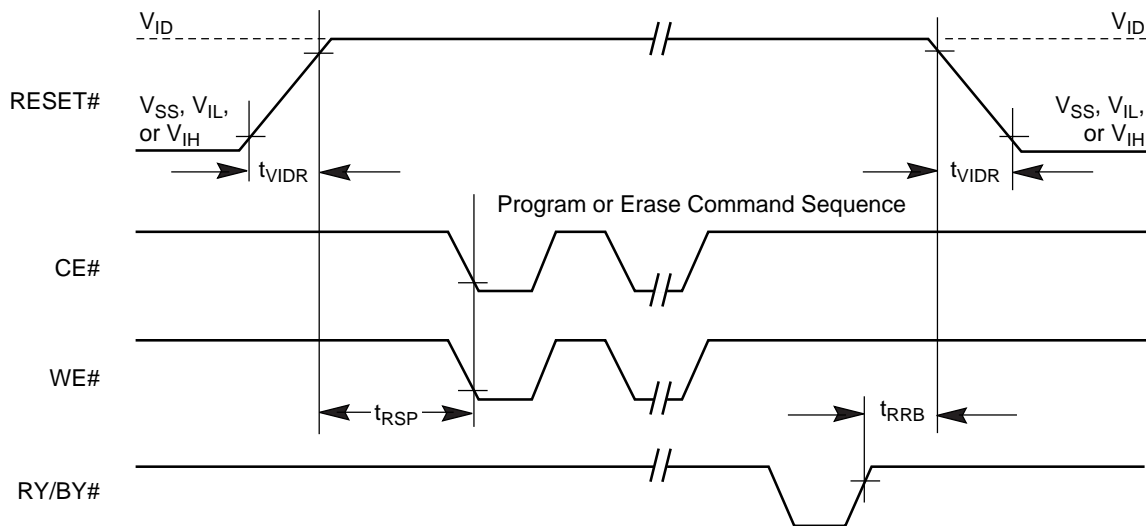

**Figure 24. Temporary Sector Unprotect Timing Diagram**

AC CHARACTERISTICS

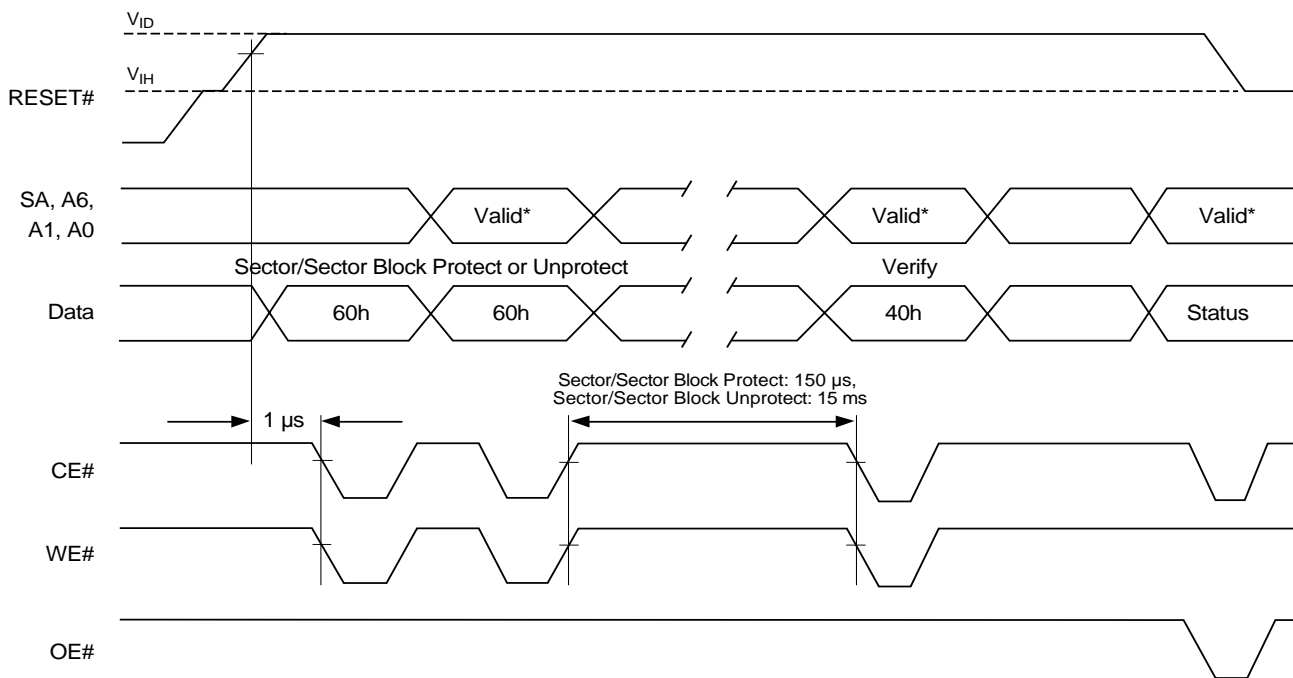

\* For sector protect, A6 = 0, A1 = 1, A0 = 0. For sector unprotect, A6 = 1, A1 = 1, A0 = 0.

Figure 25. Sector/Block Protect and Unprotect Timing Diagram

## AC CHARACTERISTICS

### Alternate CE# Controlled Erase and Program Operations

Parameter		Description		Speed Options			Unit
JEDEC	Std			70R	90	120	
$t_{AVAV}$	$t_{WC}$	Write Cycle Time (Note 1)	Min	70	90	120	ns
$t_{AVWL}$	$t_{AS}$	Address Setup Time	Min	0			ns
$t_{ELAX}$	$t_{AH}$	Address Hold Time	Min	45	45	50	ns
$t_{DVEH}$	$t_{DS}$	Data Setup Time	Min	45	45	50	ns
$t_{EHDX}$	$t_{DH}$	Data Hold Time	Min	0			ns
$t_{GHLEL}$	$t_{GHLEL}$	Read Recovery Time Before Write (OE# High to WE# Low)	Min	0			ns
$t_{WLEL}$	$t_{WS}$	WE# Setup Time	Min	0			ns
$t_{EHWH}$	$t_{WH}$	WE# Hold Time	Min	0			ns
$t_{ELEH}$	$t_{CP}$	CE# Pulse Width	Min	45	45	50	ns
$t_{EHEL}$	$t_{CPH}$	CE# Pulse Width High	Min	30			ns
$t_{WHWH1}$	$t_{WHWH1}$	Programming Operation (Note 2)	Byte	Typ			$\mu$ s
			Word	Typ			
$t_{WHWH1}$	$t_{WHWH1}$	Accelerated Programming Operation, Word or Byte (Note 2)	Typ	4			$\mu$ s
$t_{WHWH2}$	$t_{WHWH2}$	Sector Erase Operation (Note 2)	Typ	0.7			sec

**Notes:**

1. Not 100% tested.
2. See the "Erase And Programming Performance" section for more information.

AC CHARACTERISTICS

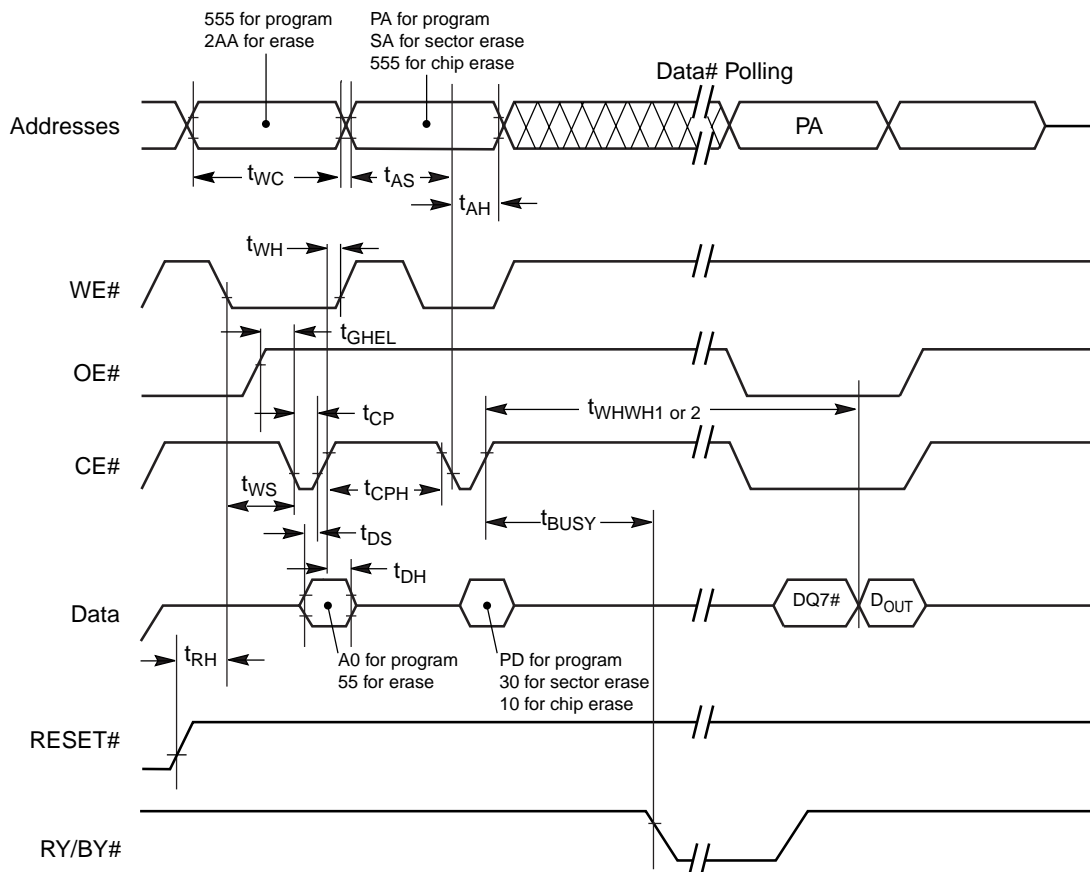

Notes:

1. Figure indicates last two bus cycles of a program or erase operation.
2. PA = program address, SA = sector address, PD = program data.
3. DQ7# is the complement of the data written to the device.  $D_{OUT}$  is the data written to the device.
4. Waveforms are for the word mode.

Figure 26. Alternate CE# Controlled Write (Erase/Program) Operation Timings

## ERASE AND PROGRAMMING PERFORMANCE

Parameter	Typ (Note 1)	Max (Note 2)	Unit	Comments
Sector Erase Time	0.7	15	sec	Excludes 00h programming prior to erasure (Note 4)
Chip Erase Time	49		sec	
Byte Program Time	5	150	μs	Excludes system level overhead (Note 5)
Accelerated Byte/Word Program Time	4	120	μs	
Word Program Time	7	210	μs	
Chip Program Time (Note 3)			sec	
	Byte Mode	21		63
	Word Mode	14	42	

### Notes:

1. Typical program and erase times assume the following conditions: 25°C, 3.0 V  $V_{CC}$ , 1,000,000 cycles. Additionally, programming typicals assume checkerboard pattern.
2. Under worst case conditions of 90°C,  $V_{CC} = 2.7$  V (3.0 V for regulated devices), 1,000,000 cycles.
3. The typical chip programming time is considerably less than the maximum chip programming time listed, since most bytes program faster than the maximum program times listed.
4. In the pre-programming step of the Embedded Erase algorithm, all bytes are programmed to 00h before erasure.
5. System-level overhead is the time required to execute the two- or four-bus-cycle sequence for the program command. See Table 14 for further information on command definitions.
6. The device has a minimum erase and program cycle endurance of 1,000,000 cycles.

## LATCHUP CHARACTERISTICS

Description	Min	Max
Input voltage with respect to $V_{SS}$ on all pins except I/O pins (including A9, OE#, and RESET#)	-1.0 V	12.5 V
Input voltage with respect to $V_{SS}$ on all I/O pins	-1.0 V	$V_{CC} + 1.0$ V
$V_{CC}$ Current	-100 mA	+100 mA

**Note:** Includes all pins except  $V_{CC}$ . Test conditions:  $V_{CC} = 3.0$  V, one pin at a time.

## TSOP AND SO PIN CAPACITANCE

Parameter Symbol	Parameter Description	Test Setup	Typ	Max	Unit
$C_{IN}$	Input Capacitance	$V_{IN} = 0$	6	7.5	pF
$C_{OUT}$	Output Capacitance	$V_{OUT} = 0$	8.5	12	pF
$C_{IN2}$	Control Pin Capacitance	$V_{IN} = 0$	7.5	9	pF

### Notes:

1. Sampled, not 100% tested.
2. Test conditions  $T_A = 25^\circ\text{C}$ ,  $f = 1.0$  MHz.

## DATA RETENTION

Parameter Description	Test Conditions	Min	Unit
Minimum Pattern Data Retention Time	150°C	10	Years
	125°C	20	Years



# PHYSICAL DIMENSIONS

## FBD063—63-ball Fine-Pitch Ball Grid Array (FBGA) 8 x 14 mm

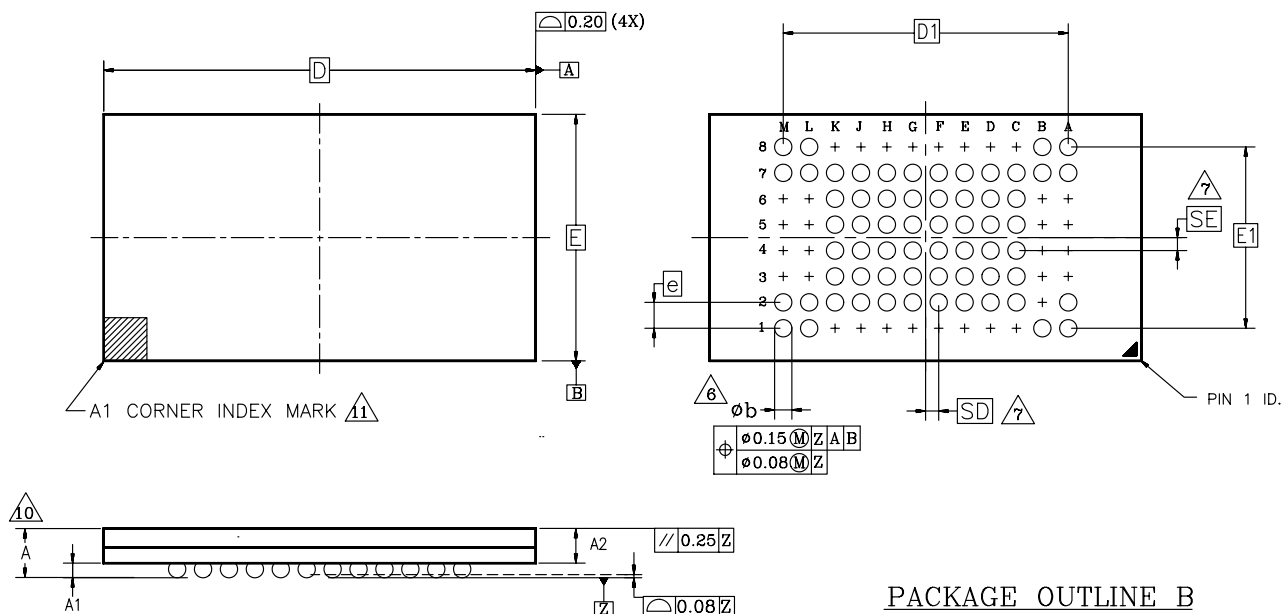

PACKAGE OUTLINE B

Dwg rev AF; 10/99

PACKAGE	xFBD 063			NOTE
JEDEC	N/A			
	8.00mmx14.00mm PACKAGE			
SYMBOL	MIN	NOM	MAX	NOTE
A	—	—	1.20	OVERALL THICKNESS
A1	0.20	—	—	BALL HEIGHT
A2	0.84	—	0.94	BODY THICKNESS
$D$	14.00 BSC			BODY SIZE
$E$	8.00 BSC			BODY SIZE
$D1$	8.80 BSC			BALL FOOTPRINT
$E1$	5.60 BSC			BALL FOOTPRINT
MD	12			ROW MATRIX SIZE D DIRECTION
ME	8			ROW MATRIX SIZE E DIRECTION
N	63			TOTAL BALL COUNT
b	0.25	0.30	0.35	BALL DIAMETER
$e$	0.80 BSC			BALL PITCH
$SD/SE$	0.40 BSC			SOLDER BALL PLACEMENT
	A3–A6, B2–B6, L3–L6, M3–M6, C1–K1, C8–K8			DEPOPULATED SOLDER BALLS

### NOTES:

- DIMENSIONING AND TOLERANCING PER ASME Y14.5M–1994.
- ALL DIMENSIONS ARE IN MILLIMETERS.
- BALL POSITION DESIGNATION PER JESD 95–1, SPP–010.
- $e$  REPRESENTS THE SOLDER BALL GRID PITCH.
- SYMBOL "MD" IS THE BALL ROW MATRIX SIZE IN THE "D" DIRECTION. SYMBOL "ME" IS THE BALL COLUMN MATRIX SIZE IN THE "E" DIRECTION. N IS THE MAXIMUM NUMBER OF SOLDER BALLS FOR MATRIX SIZE MD x ME.
- $\triangle 6$  DIMENSION "b" IS MEASURED AT THE MAXIMUM BALL DIAMETER IN A PLANE PARALLEL TO DATUM Z.
- $\triangle 7$  SD AND SE ARE MEASURED WITH RESPECT TO DATUMS A AND B AND DEFINE THE POSITION OF THE CENTER SOLDER BALL IN THE OUTER ROW. WHEN THERE IS AN ODD NUMBER OF SOLDER BALLS IN THE OUTER ROW PARALLEL TO THE D OR E DIMENSION, RESPECTIVELY, SD OR SE = 0.000 WHEN THERE IS AN EVEN NUMBER OF SOLDER BALLS IN THE OUTER ROW, SD OR SE =  $e/2$
- "X" IN THE PACKAGE VARIATIONS DENOTES PART IS UNDER QUALIFICATION.
- "+" IN THE PACKAGE DRAWING INDICATE THE THEORETICAL CENTER OF DEPOPULATED BALLS.
- $\triangle 10$  FOR PACKAGE THICKNESS A IS THE CONTROLLING DIMENSION.
- $\triangle 11$  A1 CORNER TO BE IDENTIFIED BY CHAMFER, INK MARK, METALLIZED MARKINGS INDENTION OR OTHER MEANS.

PHYSICAL DIMENSIONS

TS 048—48-Pin Standard TSOP

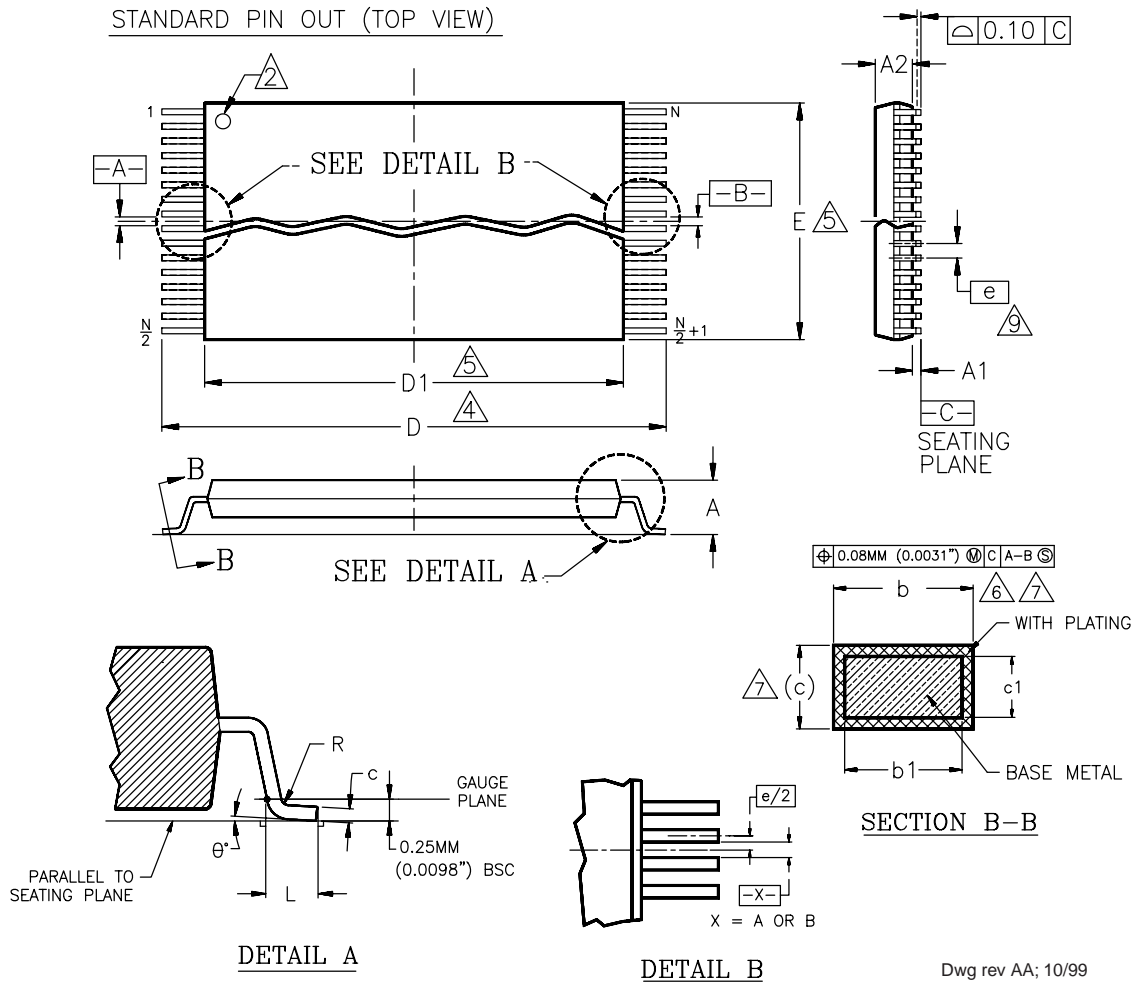

Dwg rev AA; 10/99

Package	TS 48		
Jedec	MO-142 (B) DD		
Symbol	MIN	NOM	MAX
A	—	—	1.20
A1	0.05	—	0.15
A2	0.95	1.00	1.05
b1	0.17	0.20	0.23
b	0.17	0.22	0.27
c1	0.10	—	0.16
c	0.10	—	0.21
D	19.80	20.00	20.20
D1	18.30	18.40	18.50
E	11.90	12.00	12.10
e	0.50 BASIC		
L	0.50	0.60	0.70
θ	0°	3°	5°
R	0.08	—	0.20
N	48		

NOTES:

1. CONTROLLING DIMENSIONS ARE IN MILLIMETERS (mm). (DIMENSIONING AND TOLERANCING CONFORMS TO ANSI Y14.5M-1982)
2. PIN 1 IDENTIFIER FOR STANDARD PIN OUT (DIE UP).
3. PIN 1 IDENTIFIER FOR REVERSE PIN OUT (DIE DOWN): INK OR LASER MARK.
4. TO BE DETERMINED AT THE SEATING PLANE [C-C], THE SEATING PLANE IS DEFINED AS THE PLANE OF CONTACT THAT IS MADE WHEN THE PACKAGE LEADS ARE ALLOWED TO REST FREELY ON A FLAT HORIZONTAL SURFACE.
5. DIMENSIONS D1 AND E DO NOT INCLUDE MOLD PROTRUSION. ALLOWABLE MOLD PROTRUSION IS 0.15mm (0.0059") PER SIDE.
6. DIMENSION b DOES NOT INCLUDE DAMBAR PROTRUSION. ALLOWABLE DAMBAR PROTRUSION SHALL BE 0.08mm (0.0031") TOTAL IN EXCESS OF b DIMENSION AT MAX. MATERIAL CONDITION. MINIMUM SPACE BETWEEN PROTRUSION AND AN ADJACENT LEAD TO BE 0.07mm (0.0028").
7. THESE DIMENSIONS APPLY TO THE FLAT SECTION OF THE LEAD BETWEEN 0.10mm (0.0039") AND 0.25mm (0.0098") FROM THE LEAD TIP.
8. LEAD COPLANARITY SHALL BE WITHIN 0.10mm (0.004") AS MEASURED FROM THE SEATING PLANE.
9. DIMENSION "e" IS MEASURED AT THE CENTERLINE OF THE LEADS.

## REVISION SUMMARY

### Revision B (October 1998)

#### Global

Deleted the 90R and 120R speed options. Expanded the full voltage range to 2.7–3.6 V.

#### Distinctive Characteristics

Added 125°C to 20-year data retention bullet.

#### Connection Diagrams

Changed the FBGA diagram from bottom view to top view.

#### Ordering Information

Changed the FBGA ordering nomenclature to “YD.” The package designation is now FBD063.

#### Device Bus Operations

*Accelerated Program Operation and Write Protect (WP#)* sections: Added note to indicate that the WP#/ACC must not be left floating or unconnected.

#### Command Definitions

*Unlock Bypass Command Sequence*: Added note to indicate that the WP#/ACC must not be left floating or unconnected.

#### DC Characteristics

Changed maximum  $I_{LL}$  current to  $\pm 3.0 \mu\text{A}$ .

#### Erase and Programming Performance

Replaced TBDs in table with actual values.

#### Physical Dimensions

Updated the FBGA drawing, table, and notes. The package designation is now FBD063. Deleted 40-pin TSOP drawing.

### Revision B+1 (October 1998)

#### Ordering Information

*Valid Combinations table*: Changed combinations to indicate YD for the FBGA package, but reverted to WD in revision C.

#### Sector Address table

Corrected bank divisions for both sector address tables.

#### Command Definitions table

Added the term “sector block” to the notes where appropriate.

#### DC Characteristics

Changed maximum  $I_{LL}$  current to  $\pm 1.0 \mu\text{A}$ .

#### AC Characteristics

*Temporary Sector Unprotect*: Moved the accelerated program timing diagram to follow the program operations timings. Added the term “sector block” where appropriate elsewhere on the page.

### Revision C (January 1999)

#### Global

Changed data sheet title.

#### Product Selector Guide

Replaced “Full Voltage Range:  $V_{CC} = 2.7\text{--}3.6 \text{ V}$ ” with “Standard Voltage Range:  $V_{CC} = 2.7\text{--}3.3 \text{ V}$ .” Removed 70R speed option.

#### Ordering Information

Reverted FBGA designator to WD.

#### Secured Silicon (SecSi) Sector Flash Memory Region

*Factory Locked: SecSi Sector Programmed and Protected at the Factory*: Corrected the address range of the ESN and distinguished between word and byte modes.

#### Operating Ranges

*$V_{CC}$  Supply Voltages*: Replaced full voltage range with standard voltage range.

### Revision C+1 (January 1999)

#### Sector/Sector Block Protection and Unprotection Tables

Changed the sector address range to A20—A12.

### Revision C+2 (March 17, 1999)

#### Device Bus Operations

All references to SecureSector have been changed to SecSi Sector.

#### Connection Diagrams

Modified FBGA drawing to show how outrigger balls are shorted.

### Revision C+3 (June 14, 1999)

#### Global

Changed data sheet status to Preliminary. Deleted all references to the 56-pin TSOP package.

## Revision C+4 (July 2, 1999)

### Device Bus Operations

*Sector Address Tables:* In the note below the tables, corrected the bank address bit range for Am29DL323.

## Revision C+5 (September 27, 1999)

### Device Bus Operations

Sector Address tables: Corrected the bank address bits specified.

## Revision D (December 17, 1999)

### Global

Changed Am29DL322C/323C to Am29DL322D/323D to reflect new 0.23  $\mu$ m process technology. Added 70 ns speed option.

### AC Characteristics

*Figure 17, Program Operations Timing; Figure 19, Chip/Sector Erase Operations:* Deleted  $t_{GHWL}$  and changed OE# waveform to start at high.

*Erase and Program Operations table; Alternate CE# Controlled Erase and Program Operations table:* Changed the typical and maximum specifications for programming time.

### Erase and Programming Performance

In the table, changed the typical and maximum specifications for programming time.

### Physical Dimensions

Replaced figures with more detailed illustrations.

## Revision D+1 (June 21, 2000)

### Global

Added information on the Am29DL324 device.

### Device Bus Operations

*Table 7, Autoselect Codes:* The SecSi Sector Indicator Bit values have changed from 80h and 00h to 81h and 01h, respectively.

### Command Definitions

*Table 14, Command Definitions:* The SecSi Sector Indicator Bit values have changed from 80h and 00h to 81h and 01h, respectively.

## Revision D+2 (August 3, 2000)

### Block Diagram

Corrected "A0–A19" to "A0–A20".

### Table 3. Sector Addresses for Top Boot Sector Devices

Changed the second occurrence of "Bank 2" in the Am29DL324DT column to "Bank 1". Added "A20 for Am29DL324DT" to the note.

### Table 5. Sector Addresses for Bottom Boot Sector Devices

Changed the first occurrence of "Bank 2" in the Am29DL324DB column to "Bank 1". Added "A20 for Am29DL324DB" to the note.

## Revision D+3 (October 6, 2000)

### Block Diagram

Added OE# and BYTE# inputs to lower bank section.

### Ordering Information

Deleted burn-in option. Changed 70 ns speed option from standard voltage range to regulated voltage range.

### Table 8, Top Boot Sector/Sector Block Addresses for Protection/Unprotection

Corrected SA3 address range to 000011XXX.

### RESET#: Hardware Reset Pin

Corrected reference to  $I_{CC}$  current in DC Characteristics table.

## Revision D+4 (April 27, 2001)

### Distinctive Characteristics, General Description, SecSi™ (Secured Silicon) Sector Flash Memory Region

Clarified that current version of device has 64 Kbyte SecSi Sector; future versions will have 256 bytes.

### Ordering Information

Added valid combinations for "N" designator.

### Common Flash Memory Interface (CFI)

Modified first paragraph to indicate that the CFI Query is not accessible when the device is executing an Embedded Algorithm.

### SecSi™ (Secured Silicon) Sector Flash Memory Region

Added note indicating that ACC and unlock bypass are not available when programming the SecSi Sector.

### Enter SecSi™ Sector/Exit SecSi Sector Command Sequence

Added statement that SecSi Sector is not accessible when the device is executing an Embedded Program or Embedded Erase algorithm.

---

**AC Characteristics**

*Read-only Operations:* Changed  $t_{DF}$  specification to 16 ns.

*Word/Byte Configuration:* Changed  $t_{FLQZ}$  specification to 16 ns.

**SecSi™ (Secured Silicon) Sector Flash Memory Region**

Noted changes for upcoming versions of these devices: reduced SecSi Sector size, different ESN location for top boot devices, and deletion of SecSi Sector erase functionality. Current versions of these devices remain unaffected.

**Revision D+5 (May 8, 2001)****Global**

Removed Preliminary status from data sheet.

**Trademarks**

Copyright © 2001 Advanced Micro Devices, Inc. All rights reserved.

AMD, the AMD logo, and combinations thereof are registered trademarks of Advanced Micro Devices, Inc.

ExpressFlash is a trademark of Advanced Micro Devices, Inc.

Product names used in this publication are for identification purposes only and may be trademarks of their respective companies.