Fibre Channel Transceiver Chip

Technical Data

Features

- **ANSI X3.230-1994 Fibre Channel Compatible (FC-0)**
- **Supports Full Speed (1062.5 MBd) Fibre Channel**
- **Conforms to “Fibre Channel 10-Bit Interface” Specification**
- **Transmitter and Receiver Functions Incorporated onto a Single IC**
- **10-Bit Wide Parallel TTL Compatible I/Os**
- **Single +5.0 V Power Supply**

Applications

- **1062.5 MBd Fibre Channel Interface**
- **Mass Storage System I/O Channel**
- **Work Station/Server I/O Channel**
- **High Speed Proprietary Interface**

Description

The HDMP-1526 transceiver is a single silicon bipolar integrated circuit packaged in an EDQuad package. It provides a low-cost, low-power physical layer solution for 1062.5 MBd Fibre Channel or proprietary link interfaces. It provides complete FC-0 functionality for copper transmission, incorporating both the Fibre Channel FC-0 transmit and

receive functions into a single device.

This chip is used to build a high-speed interface (as shown in Figure 1) while minimizing board space, power and cost. It is compatible with both the ANSI X3.230-1994 document and the “Fibre Channel 10-bit Interface” specification.

The transmitter section accepts 10-bit wide parallel TTL data and multiplexes this data into a high-speed serial data stream. The parallel data is expected to be 8B/10B encoded data, or equivalent. This parallel data is latched into the input register of the transmitter section on the rising edge of the 106.25 MHz reference clock (used as the transmit byte clock).

The transmitter section's PLL locks to this user supplied 106.25 MHz byte clock. This clock is multiplied by 10, to generate the 1062.5 MHz serial signal clock used to generate the high-speed output. The high-speed outputs are capable of interfacing directly to copper cables for electrical transmission or to a separate fiber-optic module for optical transmission.

The receiver section accepts a serial electrical data stream at

HDMP-1526 Transceiver



1062.5 MBd and recovers the original 10-bit wide parallel data. The receiver PLL locks onto the incoming serial signal and recovers the high-speed serial clock and data. The serial data is converted back into 10-bit parallel data, recognizing the 8B/10B comma character to establish byte alignment.

The recovered parallel data is presented to the user at TTL compatible outputs. The receiver section also recovers two 53.125 MHz receiver byte clocks that are 180 degrees out of phase with each other. The parallel data is aligned with the rising edge of alternating clocks.

The transceiver provides for on-chip local loop-back functionality, controlled through an external input pin. Additionally, the byte synchronization feature may be disabled. This may be useful in proprietary applications that use alternative methods to align the parallel data.

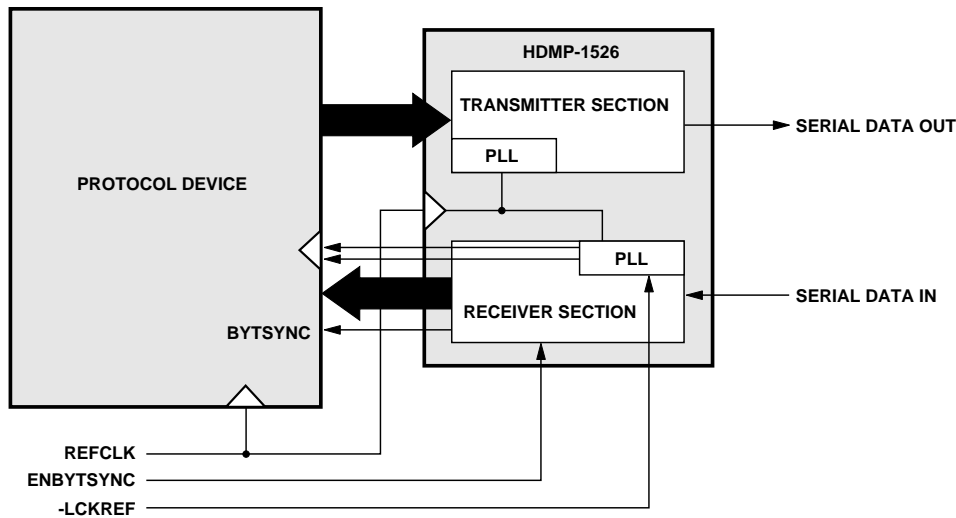

Figure 1. Typical Application Using the HDMP-1526.

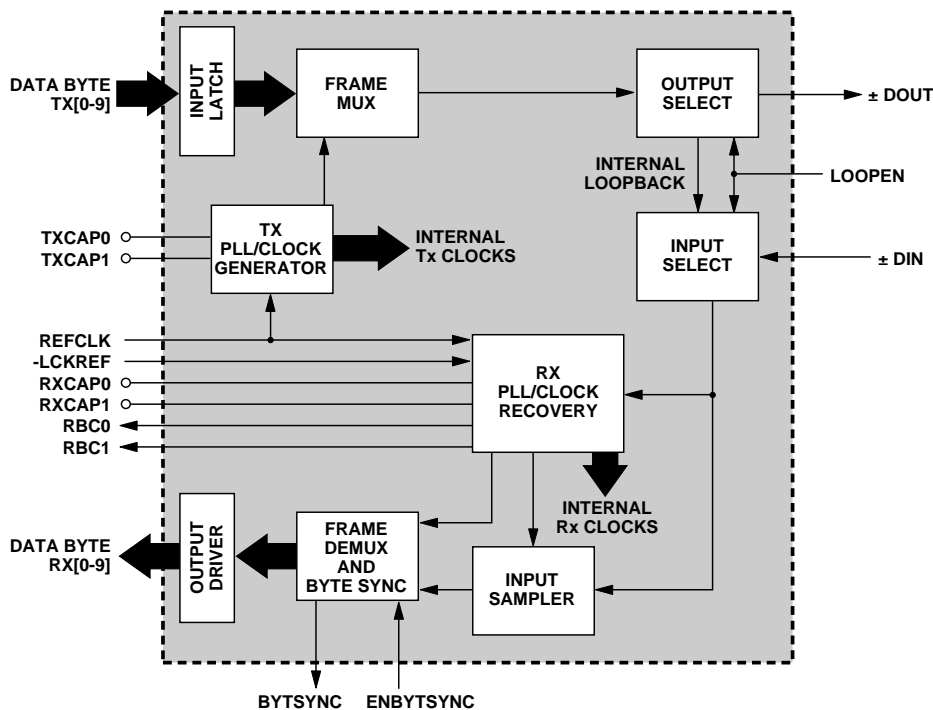

Figure 2. HDMP-1526 Transceiver Block Diagram.

HDMP-1526 Block Diagram

The HDMP-1526 was designed to transmit and receive 10-bit wide parallel data over a single high-speed line, as specified for the FC-0 layer of the Fibre Channel standard. The parallel data applied to the transmitter is expected to be encoded per the Fibre Channel specification, which uses an 8B/10B encoding scheme with special reserve characters for link management purposes. In order to accomplish this task, the HDMP-1526 incorporates the following:

- TTL Parallel I/Os
- High-Speed Phase Lock Loops
- Clock Generation/Recovery Circuitry
- Parallel-to-Serial Converter
- High-Speed Serial Clock-and-Data Recovery Circuitry
- Comma Character Recognition Circuitry
- Byte Alignment Circuitry
- Serial-to-Parallel Converter

INPUT LATCH

The transmitter accepts 10-bit wide TTL parallel data at inputs TX[0..9]. The user-provided reference clock signal, REFCLK, is also used as the transmit byte clock. The TX[0..9] and REFCLK signals must be properly aligned, as shown in Figure 3.

TX PLL/CLOCK GENERATOR

The transmitter Phase Lock Loop and Clock Generator (TX PLL/CLOCK GENERATOR) block is responsible for generating all internal clocks needed by the transmitter section to perform its functions. These clocks are based on the supplied reference byte clock (REFCLK). REFCLK is used as both the frequency reference clock for the PLL and the transmit byte clock for the incoming data latches. It is expected to be 106.25 MHz and properly aligned to the incoming

parallel data (see Figure 3). This clock is multiplied by 10 to generate the 1062.5 MHz clock necessary for the high-speed serial outputs.

FRAME MUX

The FRAME MUX accepts the 10-bit wide parallel data from the INPUT LATCH. Using internally generated high-speed clocks, this parallel data is multiplexed into the 1062.5 Mbd serial data stream. The data bits are transmitted sequentially, from the least significant bit (TX[0]) to the most significant bit (TX[9]).

OUTPUT SELECT

The OUTPUT SELECT block provides for an optional internal loopback of the high-speed serial signal, for testing purposes.

In normal operation, LOOPEN is set low and the serial data stream is placed at \pm DOUT. When wrap-mode is activated by setting LOOPEN high, the \pm DOUT pins are held static and the serial output signal is internally wrapped to the INPUT SELECT box of the receiver section.

INPUT SELECT

The INPUT SELECT block determines whether the signal at \pm DIN or the internal loop-back serial signal is used. In normal operation, LOOPEN is set low and the serial data is accepted at \pm DIN. When LOOPEN is set high, the high-speed serial signal is internally looped-back from the transmitter section to the receiver section. This feature allows for loop-back testing exclusive of the transmission medium.

RX PLL/CLOCK RECOVERY

The RX PLL/CLOCK RECOVERY block is responsible for frequency and phase locking onto incoming serial data stream and recovering the bit and byte clocks.

In order to accomplish this, upon startup, the user should set -LCKREF low for a period of at least 500 μ sec. This allows the PLL to first frequency lock onto the 106.25 MHz reference clock provided at the REFCLK input. The RX PLL/CLOCK RECOVERY circuitry multiplies this reference clock by 10 to generate an internal 1062.5 MHz clock. After 500 μ sec, the user should set -LCKREF high. This will allow the receiver to frequency and phase lock the internal 1062.5 MHz clock onto the incoming serial data stream. Once locked, the receiver will recover the two 53.125 MHz receiver byte clocks (RBC1/RBC0). These byte clocks are approximately 180° out of phase with each other and are alternately used to clock the 10-bit parallel output data.

INPUT SAMPLER

The INPUT SAMPLER is responsible for converting the serial input signal into a retimed serial bit stream. In order to accomplish this, it uses the high speed serial clock recovered from the RX PLL/CLOCK RECOVERY block. This serial bit stream is sent to the FRAME DEMUX and BYTE SYNC block.

FRAME DEMUX AND BYTE SYNC

The FRAME DEMUX AND BYTE SYNC block is responsible for restoring the 10-bit parallel data from the high speed serial bit stream. This block is also responsible for recognizing the comma character (or a K28.5 character) of positive disparity (0011111xxx). When recognized, the FRAME DEMUX AND BYTE SYNC block works with the RX PLL/CLOCK RECOVERY block to properly align the receive byte clocks to the parallel data. When a comma character is detected and realignment of the receiver byte clocks (RBC1/RBC0) is necessary, these clocks are stretched, not slivered, to the next possible correct alignment position. These clocks will be fully aligned by the start of the second 4-byte ordered set. The second comma character received shall be aligned with the rising edge of RBC1. Comma characters should not be transmitted in consecutive succession to allow the receiver byte clocks to maintain their proper recovered frequencies.

OUTPUT DRIVERS

The OUTPUT DRIVERS present the 10-bit parallel recovered data byte properly aligned to the receive byte clocks (RBC1/RBC0), as shown in Figure 4. These output data buffers provide TTL compatible signals.

HDMP-1526 (Transmitter Section)

Timing Characteristics

$T_C = 0^\circ\text{C}$ to $+85^\circ\text{C}$, $V_{CC} = 4.5\text{ V}$ to 5.25 V

Symbol	Parameter	Units	Min.	Typ.	Max.
t_{setup}	Setup Time	nsec	2		
t_{hold}	Hold Time	nsec	1.5		
$t_{\text{txlat}}^{[1]}$	Transmitter Latency	nsec		6.25	12.2
		bits		6.64	13.0

Note:

1. The transmitter latency, as shown in Figure 4, is defined as the time between the latching in of the parallel data word (as triggered by the rising edge of the transmit byte clock, REFCLK) and the transmission of the first serial bit of that parallel word (defined by the rising edge of the first bit transmitted).

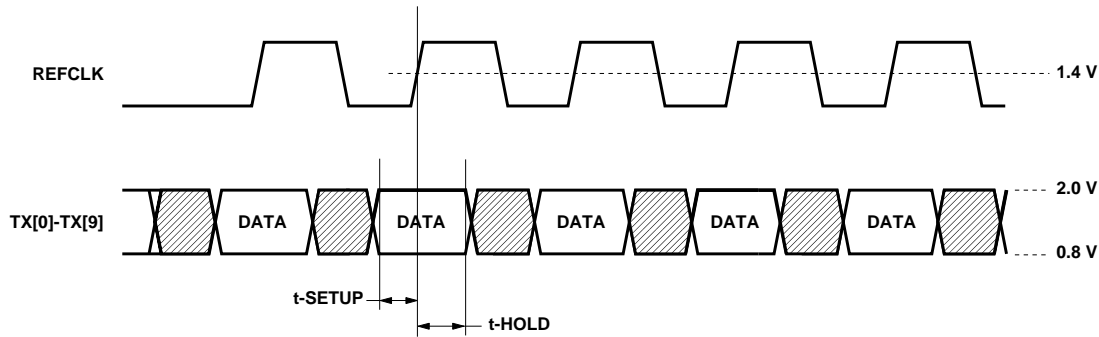

Figure 3. Transmitter Section Timing.

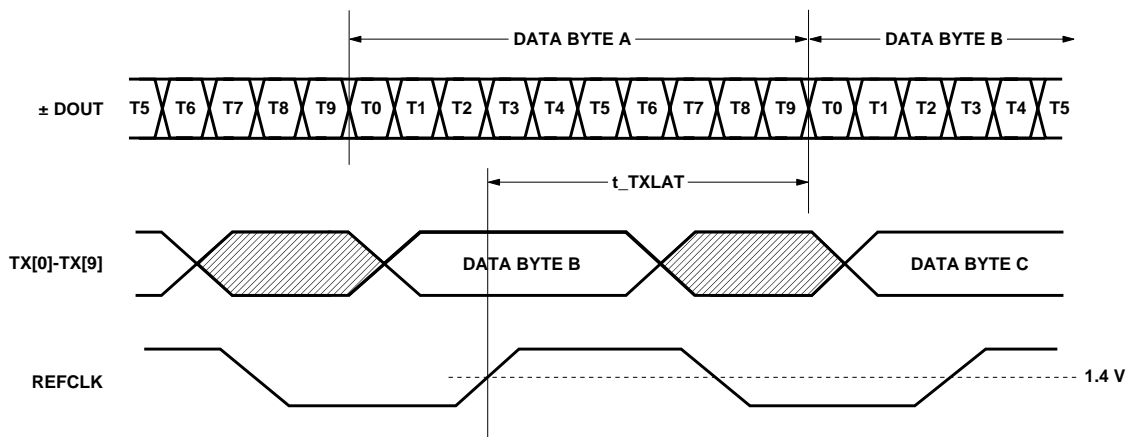

Figure 4. Transmitter Latency.

HDMP-1526 (Receiver Section)

Timing Characteristics

$T_C = 0^\circ\text{C to } +85^\circ\text{C}$, $V_{CC} = 4.5\text{ V to } 5.25\text{ V}$

Symbol	Parameter	Units	Min.	Typ.	Max.
b_sync ^[1,2]	Bit Sync Time	bits			2500
f_lock ^[2]	Frequency Lock Time (from Time of Setting -LCKREF = 0)	μsec			500
f_lock_rate ^[2]	Frequency Lock Rate (when -LCKREF = 0)	$\text{kHz}/\mu\text{sec}$		200	
t_valid_before	Time Data Valid Before Rising Edge of RBC	nsec	3	5.8	
t_valid_after	Time Data Valid After Rising Edge of RBC	nsec	1.5	3.3	
t_duty	RBC Duty Cycle	%	40		60
t _{A-B} ^[3]	Rising Edge Time Difference	nsec	8.9	9.4	9.9
t_rxlat ^[4]	Receiver Latency	nsec		25.0	33.9
		bits		26.6	36

Notes:

1. This is the recovery time for input phase jumps, per the FC-PH specification Ref 4.1, Sec 5.3.
2. Tested using $C_{PLL} = 0.01\ \mu\text{F}$.
3. The RBC clock skew is calculated as $t_{A-B(\text{max})} - t_{A-B(\text{min})}$.
4. The receiver latency, as shown in Figure 5, is defined as the time between receiving the first serial bit of a parallel data word (as defined as the first edge of the first serial bit) and the clocking out of that parallel word (defined by the rising edge of the receive byte clock, either RBC1 or RBC0).

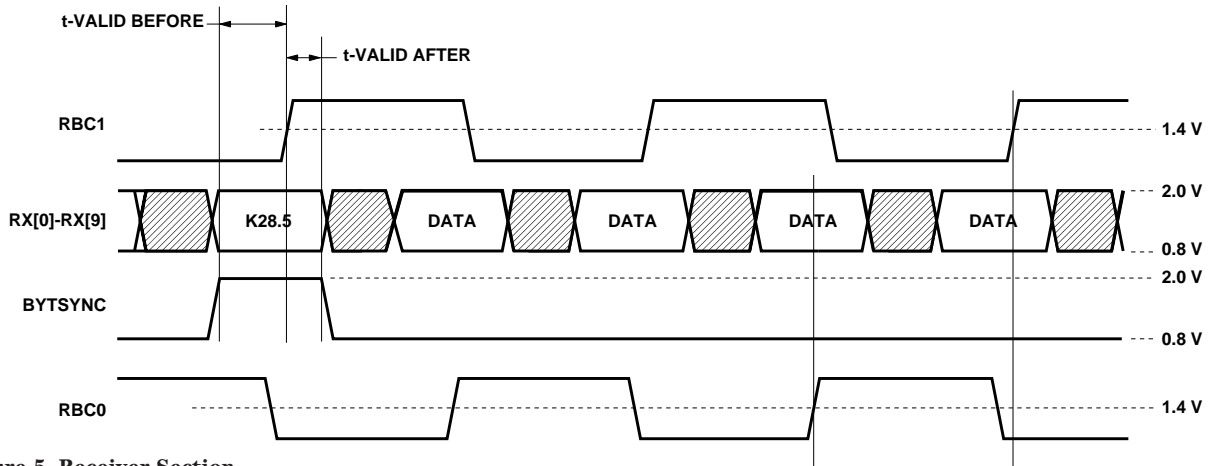

Figure 5. Receiver Section.

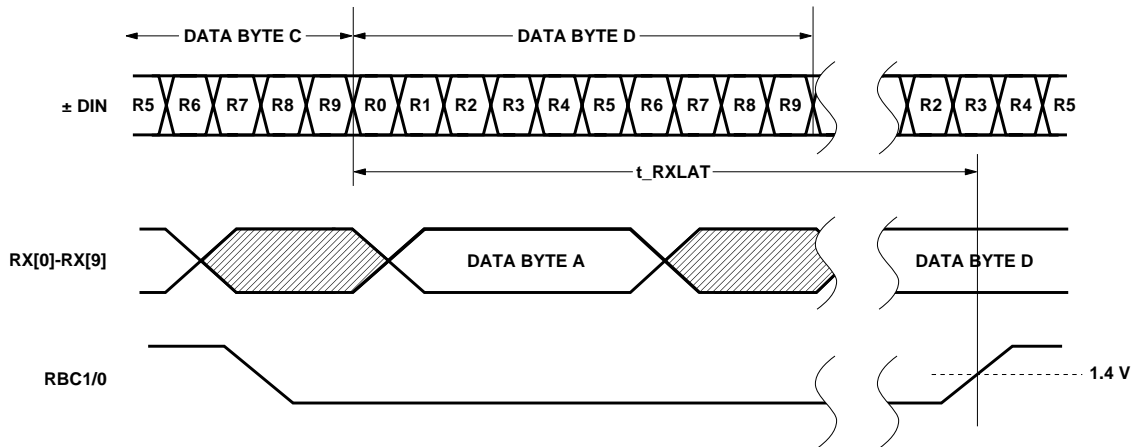

Figure 6. Receiver Latency.

HDMP-1526 (TRx)

Absolute Maximum Ratings

$T_A = 25^\circ\text{C}$, except as specified. Operation in excess of any one of these conditions may result in permanent damage to this device.

Symbol	Parameter	Units	Min.	Max.
V_{CC}	Supply Voltage	V	-0.5	6.0
$V_{IN,TTL}$	TTL Input Voltage	V	-0.7	$V_{CC} + 0.7$
V_{IN,HS_IN}	HS_IN Input Voltage	V	2.0	V_{CC}
$I_{O,TTL}$	TTL Output Source Current	mA		13
T_{stg}	Storage Temperature	$^\circ\text{C}$	-40	+130
T_j	Junction Operating Temperature	$^\circ\text{C}$	0	+130
	Maximum Assembly Temperature (for 10 seconds maximum)	$^\circ\text{C}$		+260

HDMP-1526 (TRx)

Recommended Operating Conditions

Symbol	Parameter	Units	Min.	Max.
V_{CC}	Supply Voltage	V	4.5	5.25
T_C	Case Temperature	$^\circ\text{C}$	0	85

HDMP-1526 (TRx)

Transceiver Reference Clock Requirements

$T_C = 0^\circ\text{C}$ to $+85^\circ\text{C}$, $V_{CC} = 4.5\text{ V}$ to 5.25 V

Symbol	Parameter	Unit	Min.	Typ.	Max.
f	Nominal Frequency (for Fibre Channel Compliance)	MHz	106.20	106.25	106.30
F_{tol}	Frequency Tolerance	ppm	-100		+100
Symm	Symmetry (Duty Cycle)	%	40		60

HDMP-1526 (Trx)

DC Electrical Specifications

$T_C = 0^\circ\text{C}$ to $+85^\circ\text{C}$, $V_{CC} = 4.5\text{ V}$ to 5.25 V

Symbol	Parameter	Unit	Min.	Typ.	Max.
$V_{IH,TTL}$	TTL Input High Voltage Level, Guaranteed High Signal for All TTL Inputs	V	2		V_{CC}
$V_{IL,TTL}$	TTL Input Low Voltage Level, Guaranteed Low Signal for All TTL Inputs	V	0		0.8
$V_{OH,TTL}$	TTL Output High Voltage Level, $I_{OH} = -400\ \mu\text{A}$	V	2.4		V_{CC}
$V_{OL,TTL}$	TTL Output Low Voltage Level, $I_{OL} = 1\text{ mA}$	V	0		0.6
$I_{IH,TTL}$	Input High Current (Magnitude), $V_{IN} = V_{CC}$	μA		0.004	40
$I_{IL,TTL}$	Input Low Current (Magnitude), $V_{IN} = 0\text{ Volts}$	μA		295	600
$I_{CC,TRX}^{[1,2]}$	Transceiver V_{CC} Supply Current, $T_A = 25^\circ\text{C}$	mA		375	475

Notes:

1. Measurement Conditions: Tested sending 1062.5 MBd PRBS 2⁷-1 sequence with both DOUT outputs biased with 270 Ω resistors and the receiver TTL outputs driving 10 pF loads.
2. Typical specified with $V_{CC} = 5.0\text{ volts}$, maximum specified with $V_{CC} = 5.25\text{ volts}$.

HDMP-1526 (TRx)

AC Electrical Specifications

$T_C = 0^\circ\text{C}$ to $+85^\circ\text{C}$, $V_{CC} = 4.5\text{ V}$ to 5.25 V

Symbol	Parameter	Units	Min.	Typ.	Max.
$t_{r,TTLin}$	Input TTL Rise Time, 0.8 to 2.0 Volts	nsec		2	
$t_{f,TTLin}$	Input TTL Fall Time, 2.0 to 0.8 Volts	nsec		2	
$t_{r,TTLout}$	Output TTL Rise Time, 0.8 to 2.0 Volts, 10 pF Load	nsec		1.1	2.4
$t_{f,TTLout}$	Output TTL Fall Time, 2.0 to 0.8 Volts, 10 pF Load	nsec		1.5	2.4
$t_{rs,HS_OUT}^{[1,2]}$	HS_OUT Single-Ended (+DOUT) Rise Time	psec		190	400
$t_{fs,HS_OUT}^{[1,2]}$	HS_OUT Single-Ended (+DOUT) Fall Time	psec		170	400
$t_{rd,HS_OUT}^{[1,2,3]}$	HS_OUT Differential Rise Time	psec		180	
$t_{fd,HS_OUT}^{[1,2,3]}$	HS_OUT Differential Fall Time	psec		230	
$V_{IP,HS_IN}^{[3,4]}$	HS_IN Input Peak-to-Peak Differential Voltage	mV	200	1200	2200
$V_{OP,HS_OUT}^{[1,3]}$	HS_OUT Output Peak-to-Peak Differential Voltage	mV	1200	1740	2200

Notes:

- Each output is measured with a $270\ \Omega$ bias resistor to ground and a $50\ \Omega$ AC load.
- Specified between 20% and 80% points of full voltage swing.
- Output Peak-to-Peak Differential Voltage specified as DOUT+ minus DOUT-.
- Measured using a $50\ \Omega$ load.

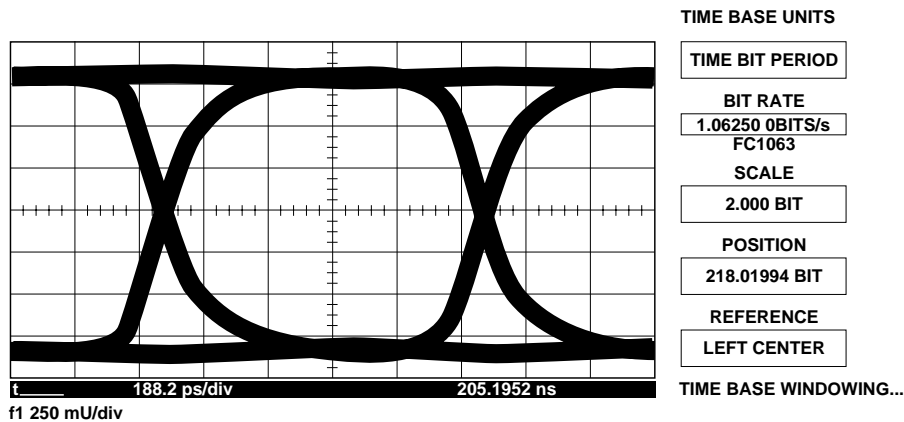

a. Differential HS_OUT Output (Dout+ Minus Dout-).

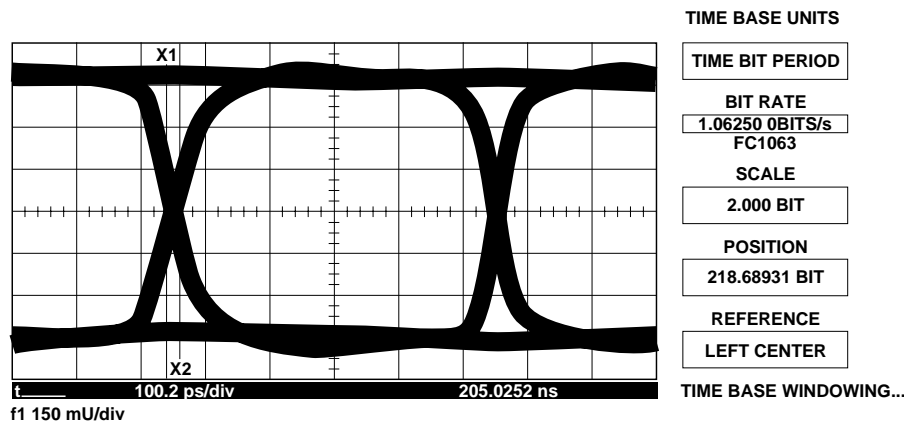

b. Single-Ended HS_OUT Output (Dout+).

Figure 7. Transmitter DOUT Eye Diagrams.

HDMP-1526 (Transmitter Section)

Output Jitter Characteristics

$T_C = 0^\circ\text{C}$ to $+85^\circ\text{C}$, $V_{CC} = 4.5\text{ V}$ to 5.25 V

Symbol	Parameter	Units	Typ.
RJ ^[1]	Random Jitter at DOUT, the High Speed Electrical Data Port, specified as 1 sigma deviation of the 50% crossing point	ps	8
DJ ^[1]	Deterministic Jitter at DOUT, the High Speed Electrical Data Port	ps	35

Note:

1. Defined by Fibre Channel Specification Rev 4.1, Annex A, Section A.4 and tested using measurement method shown in Figure 8.

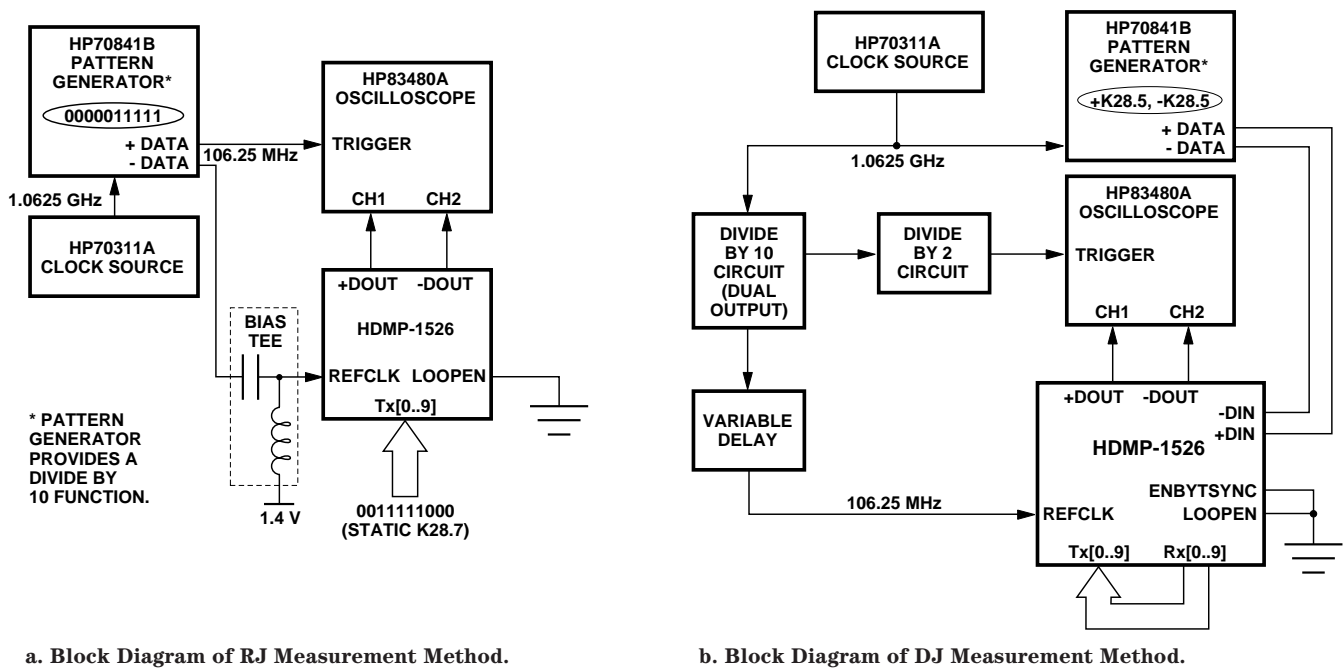

Figure 8. Transmitter Jitter Measurement Method.

HDMP-1526 (TRx)

Thermal and Power Temperature Characteristics,

$T_C = 0^\circ\text{C}$ to $+85^\circ\text{C}$, $V_{CC} = 4.5\text{ V}$ to 5.25 V

Symbol	Parameter	Units	Typ.	Max.
$P_{D,TRx}^{[1,2]}$	Transceiver Power Dissipation, Outputs Open, Parallel Data has 5 Ones and 5 Zeroes	Watt	1.6	
$P_{D,TRx}^{[1,2,3]}$	Transceiver Power Dissipation, Outputs Connected per Recommended Bias Terminations	Watt	1.8	2.4
$\Theta_{jc}^{[4]}$	Thermal Resistance, Junction to Case	$^\circ\text{C}/\text{Watt}$	7	

Notes:

- PD is calculated by multiplying the max V_{CC} by the max I_{CC} and subtracting the power dissipated outside the chip at the high speed bias resistors.
- Typical specified with $V_{CC} = 5$ volts, maximum specified with $V_{CC} = 5.25$ volts.
- Specified with high speed outputs biased with $270\ \Omega$ resistors and receiver TTL outputs driving 10 pF loads. Pattern is PRBS 2^7-1 .
- Based on independant package testing by HP.

I/O Type Definitions

I/O Type	Definition
I-TTL	Input TTL. Floats High When Left Open.
O-TTL	Output TTL
HS_OUT	High Speed Output. ECL Compatible
HS_IN	High Speed Input, Internally Biased, High Input Resistance
C	External Circuit Node
S	Power Supply or Ground

HDMP-1526 (TRx)

Pin Input Capacitance

Symbol	Parameter	Units	Typ.	Max.
C_{INPUT}	Pin Input Capacitance	pF	1.6	4.0

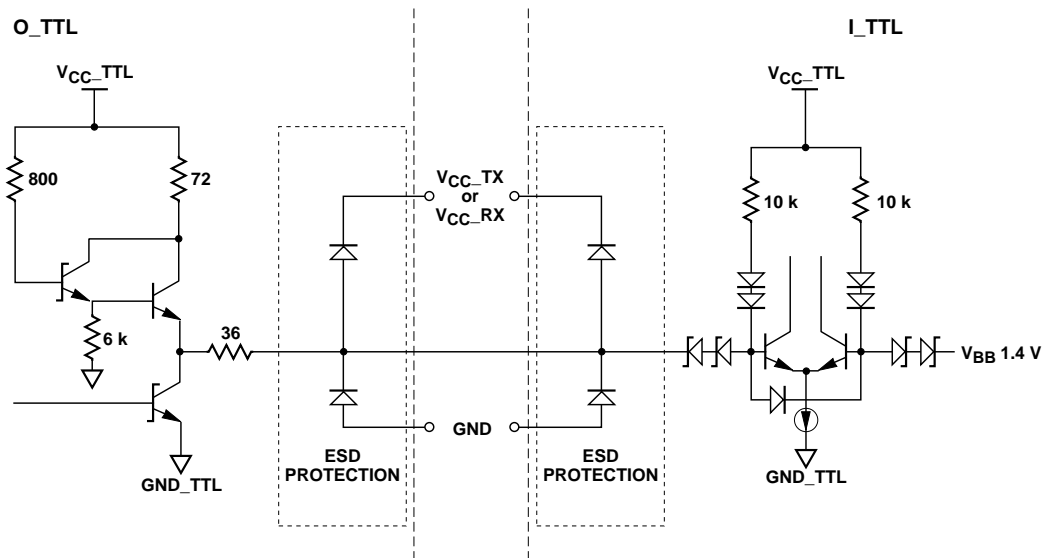

Figure 9. O-TTL and I-TTL Simplified Circuit Schematic.

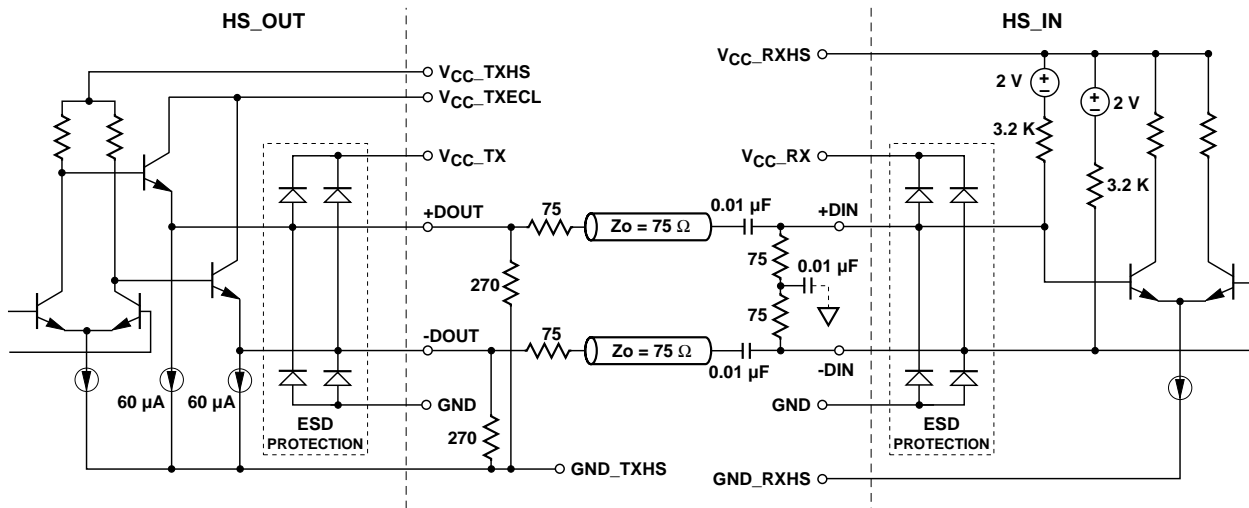

Figure 10. HS_OUT and HS_IN Simplified Circuit Schematic.

Notes:

1. HS_IN inputs should never be connected to ground as permanent damage to the device may result.
2. 75 Ω serial padding resistors are optional, the serial resistors should be matched to the receiver input bias resistors.

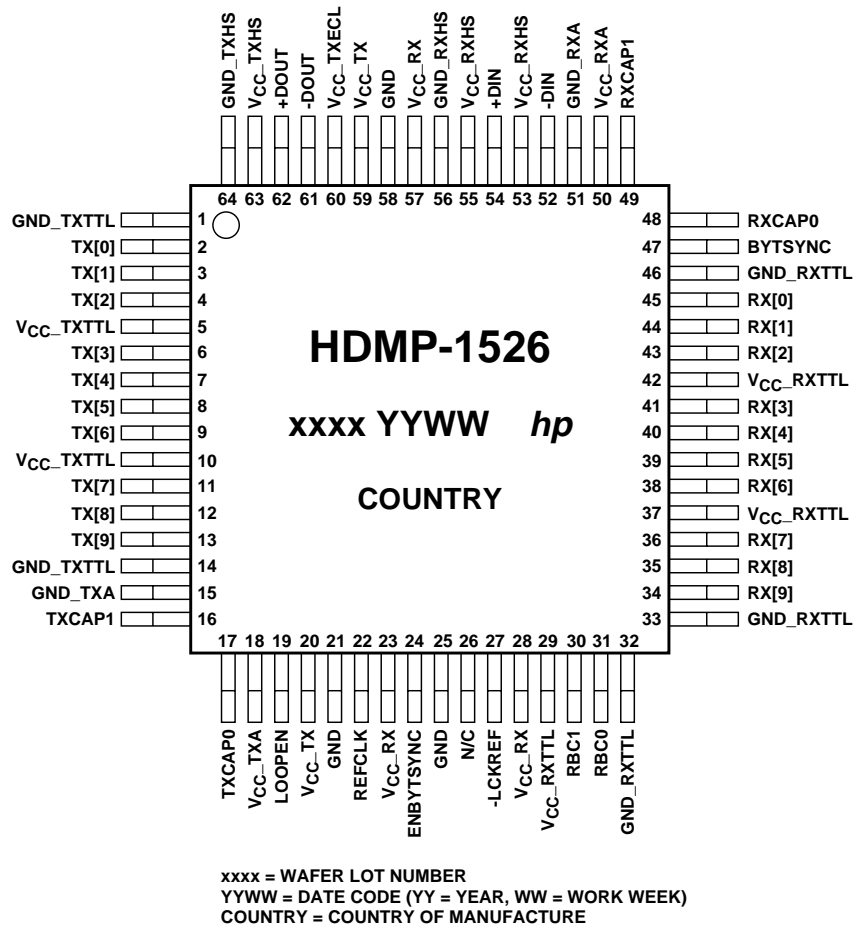

Figure 11. HDMP-1526 (TRx) Package Layout and Marking, Top View.

TRx I/O Definition

Name	Pin	Type	Signal
GND_TXTTL	1 14	S	TTL Transmitter Ground: Normally 0 volts. Used for the TTL input cells of the transmitter section.
TX[0] TX[1] TX[2] TX[3] TX[4] TX[5] TX[6] TX[7] TX[8] TX[9]	2 3 4 6 7 8 9 11 12 13	I-TTL	Data Inputs: One, 10 bit, pre-encoded data byte. TX[0] is the first bit transmitted. TX[9] is the least significant bit.
VCC_TXTTL	5 10	S	TTL Power Supply: Normally 5 volts. Used for all TTL transmitter input buffer cells.
GND_TXA	15	S	Analog Ground: Normally 0 volts. Used to provide a clean ground plane for the PLL and high-speed analog cells.
TXCAP1 TXCAP0	16 17	C	Loop Filter Capacitor: A loop filter capacitor must be connected across the TXCAP1 and TXCAP0 pins (typical value = 0.01 μ F).
VCC_TXA	18	S	Analog Power Supply: Normally 5 volts. Used to provide a clean supply line for the PLL and high-speed analog cells.
LOOPEN	19	I-TTL	Loopback Enable Input: When set high, the high-speed serial signal is internally wrapped from the transmitter's serial loopback outputs back to the receiver's loopback inputs. Also, when in loopback mode, the \pm DOUT outputs are held static. When set low, \pm DOUT outputs and \pm DIN inputs are active.
VCC_TX	20 59	S	Logic Power Supply: Normally 5 volts. Used for internal transmitter PECL logic. It should be isolated from the noisy TTL supply as well as possible.
GND	21 25 58	S	Logic Ground: Normally 0 volts. This ground is used for internal PECL logic. It should be isolated from the noisy TTL ground as well as possible.
REFCLK	22	I-TTL	Reference Clock and Transmit Byte Clock: A 106.25 MHz clock supplied by the host system. The transmitter section accepts this signal as the frequency reference clock. It is multiplied by 10 to generate the serial bit clock and other internal clocks. The transmit side also uses this clock as the transmit byte clock for the incoming parallel data TX[0]..TX[9]. It also serves as the reference clock for the receive portion of the transceiver. When -LCKREF is activated, the receiver PLL frequency locks to this reference signal.
VCC_RX	23 28 57	S	Logic Power Supply: Normally 5 volts. Used for internal receiver PECL logic. It should be isolated from the noisy TTL supply as well as possible.
ENBYTSYNC	24	I-TTL	Enable Byte Sync Input: When high, enables the internal byte sync function to allow clock synchronization to a comma character (or a K28.5 character) of positive disparity (0011111010). When the line is low, the function is disabled and will not reset registers and clocks, or strobe the BYTSYNC line.
-LCKREF	27	I-TTL	Lock to Reference: When low, causes the PLL to acquire frequency lock on the external reference, supplied at REFCLK.

TRx I/O Definition (cont'd.)

Name	Pin	Type	Signal
VCC_RXTTL	29 37 42	S	TTL Power Supply: Normally 5 volts. Used for all TTL receiver output buffer cells.
RBC1 RBC0	30 31	O-TTL	Receiver Byte Clocks: The receiver section recovers two 53.125 MHz receive byte clocks. These two clocks are approximately 180 degrees out of phase. The receiver parallel data outputs are alternatively clocked on the rising edge of these clocks. RBC1 aligns and outputs the comma character (for byte alignment) when detected.
GND_RXTTL	32 33 46	S	TTL Receiver Ground: Normally 0 volts. Used for the TTL output cells of the receiver section.
RX[0] RX[1] RX[2] RX[3] RX[4] RX[5] RX[6] RX[7] RX[8] RX[9]	45 44 43 41 40 39 38 36 35 34	O-TTL	Data Outputs: One 10 bit data byte. RX[0] is the first bit received. RX[9] is the least significant bit.
BYTSYNC	47	O-TTL	Byte Sync Output: An active high output. Used to indicate detection of either a comma character or a K28.5 special character of positive disparity. It is only active when ENBYTSYNC is enabled.
RXCAP0 RXCAP1	48 49	C	Loop Filter Capacitor: A loop filter capacitor for the internal PLL is connected across the RXCAP0 and RXCAP1 pins. (typical value = 0.01 μ F).
VCC_RXA	50	S	Analog Power Supply: Normally 5 volts. Used to provide a clean supply line for the PLL and high-speed analog cells.
GND_RXA	51	S	Analog Ground: Normally 0 volts. Used to provide a clean ground plane for the receiver PLL and high-speed analog cells.
-DIN +DIN	52 54	HS_IN	Serial Data Inputs: High-speed inputs. Serial data is accepted from the \pm DIN inputs when LOOPEN is low.
VCC_RXHS	53 55	S	High-Speed Supply: Normally 5 volts. Used only for the high-speed receiver cell (HS_IN). Noise on this line should be minimized for best operation.
GND_RXHS	56	S	Ground: Normally 0 volts.
VCC_TXECL	60	S	High-Speed ECL Supply: Normally 5 volts. Used only for the last stage of the high-speed transmitter output cell (HS_OUT) as shown in Figure 9. Due to high current transitions, this V _{CC} should be well bypassed to a ground plane.
VCC_TXHS	63	S	High-Speed Supply: Normally 5 volts. Used by the transmitter side for the high-speed circuitry. Noise on this line should be minimized for best operation.
-DOUT +DOUT	61 62	HS_OUT	Serial Data Outputs: High-speed outputs. These lines are active when LOOPEN is set low. When LOOPEN is set high, these outputs are held static.
GND_TXHS	64	S	Ground: Normally 0 volts.

Transceiver Power Supply Bypass and Loop Filter Capacitors

Bypass capacitors should be liberally used and placed as close as possible to the appropriate power supply pins of the HDMP-1526 as shown on the schematic of Figure 11. All bypass chip capacitors are 0.1 μF . The V_{CC_RXA} and V_{CC_TXA} pins are the analog power supply pins for the PLL sections. The voltage into these pins should be clean with minimum noise. The PLL loop filter capacitors and their pin locations are also shown on Figure 11. Notice that only two capacitors are required: C_{PLL_T} for the transmitter and C_{PLL_R} for the receiver. Nominal capacitance is 0.01 μF . The voltage across the capacitors is on the order of 1 volt, so the capacitor can be a low voltage type and physically small. The PLL capacitors are placed physically close to the appropriate pins on the HDMP-1526. Keeping the lines short will prevent them from picking up stray noise from surrounding lines or components.

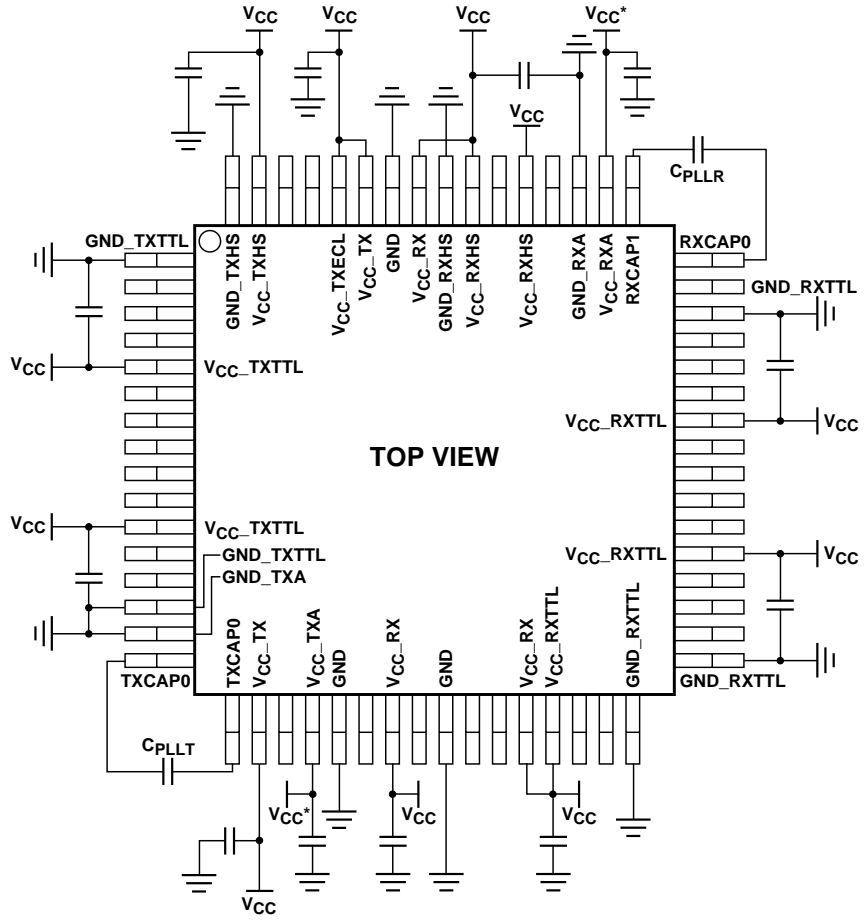

* SUPPLY VOLTAGE INTO V_{CC_RXA} AND V_{CC_TXA} SHOULD BE FROM A LOW NOISE SOURCE. ALL BYPASS CAPACITORS ARE 0.1 μF . THE PLL FILTER CAPACITORS ARE 0.01 μF .

Figure 12. Power Supply Bypass.

Transceiver Package Information

The HDMP-1526 is constructed of a single integrated circuit packaged in a 14x14 mm EDQuad package. This package was designed to provide enhanced power dissipation, thus allowing for smaller package dimensions. The package conforms to the industry standard JEDEC land pattern for 14x14 mm devices. As shown in Figure 12, the die is attached to a copper heatsink using thermally conductive epoxy. This allows for

the power dissipated by the IC to be directly connected to the ambient environment, thereby minimizing the Θ_{jc} of the device.

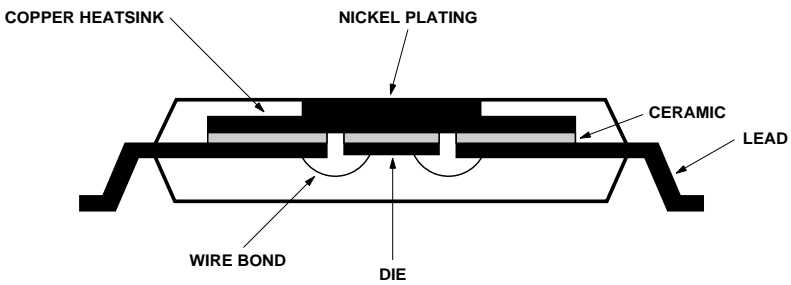

Figure 13. Package Cross Section of HDMP-1526.

