

Hermetically Sealed, Transistor Output Optocouplers for Analog and Digital Applications

Technical Data

Agilent 4N55*, 5962-87679, HCPL-553X, HCPL-653X, HCPL-257K, HCPL-655X, 5962-90854, HCPL-550X

*See matrix for available extensions.

Description

These units are single, dual and quad channel, hermetically sealed optocouplers. The products are capable of operation and storage over the full military temperature range and can be purchased as either standard product or with full MIL-PRF-38534 Class Level H or K testing or from the appropriate DSCC Drawing. All devices are manufactured and tested on a MIL-PRF-38534 certified line and are included in the DSCC Qualified Manufacturers List QML-38534 for Hybrid Microcircuits.

Applications

- Military and Space
- High Reliability Systems
- Vehicle Command, Control, Life Critical Systems
- Line Receivers
- Switching Power Supply
- Voltage Level Shifting
- Analog Signal Ground Isolation (see Figures 7, 8, and 13)
- Isolated Input Line Receiver
- Isolated Output Line Driver
- Logic Ground Isolation
- Harsh Industrial Environments
- Isolation for Test Equipment Systems

Features

- Dual Marked with Device Part Number and DSCC Drawing Number
- Manufactured and Tested on a MIL-PRF-38534 Certified Line
- QML-38534, Class H and K
- Five Hermetically Sealed Package Configurations
- Performance Guaranteed, Over -55°C to +125°C
- High Speed: Typically 400 kBit/s
- 9 MHz Bandwidth
- Open Collector Output
- 2-18 Volt V_{CC} Range
- 1500 Vdc Withstand Test Voltage
- High Radiation Immunity
- 6N135, 6N136, HCPL-2530/2531, Function Compatibility
- Reliability Data

The connection of a 0.1 μ F bypass capacitor between V_{CC} and GND is recommended.

CAUTION: It is advised that normal static precautions be taken in handling and assembly of this component to prevent damage and/or degradation which may be induced by ESD.



Agilent Technologies

Each channel contains a GaAsP light emitting diode which is optically coupled to an integrated photon detector. Separate connections for the photodiodes and output transistor collectors improve the speed up to a hundred times that of a conventional phototransistor optocoupler by reducing the base-collector capacitance.

These devices are suitable for wide bandwidth analog applications, as well as for interfacing TTL to LSTTL or CMOS. Current Transfer Ratio (CTR) is 9% minimum at $I_F = 16 \text{ mA}$. The 18 V V_{CC} capability will enable the designer to interface any TTL family to CMOS. The availability of the base lead allows optimized gain/bandwidth adjustment in analog applications. The shallow depth of the IC photodiode provides better radiation immunity than conventional phototransistor couplers.

These products are also available with the transistor base node not connected to improve common mode noise immunity and ESD susceptibility. In addition, higher CTR minimums are available by special request.

Package styles for these parts are 8 and 16 pin DIP through hole (case outlines P and E respectively), 16 pin DIP flat pack (case outline F), and leadless ceramic chip carrier (case outline 2). Devices may be purchased with a variety of lead bend and plating options, see Selection Guide Table for details. Standard Microcircuit Drawing (SMD) parts are available for each package and lead style.

Because the same functional die (emitters and detectors) are used for each channel of each device listed in this data sheet, absolute maximum ratings, recommended operating conditions, electrical specifications, and performance

characteristics shown in the figures are identical for all parts. Occasional exceptions exist due to package variations and limitations and are as noted. Additionally, the same package assembly processes and materials are used in all devices. These similarities give justification for the use of data obtained from one part to represent other part's performance for die related reliability and certain limited radiation test results.

Truth Table

(Positive Logic)

Input	Output
On (H)	L
Off (L)	H

Functional Diagram

Multiple Channel Devices Available

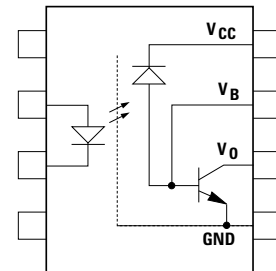

Selection Guide—Package Styles and Lead Configuration Options

Package	16 Pin DIP	8 Pin DIP	8 Pin DIP	16 Pin Flat Pack	20 Pad LCCC
Lead Style	Through Hole	Through Hole	Through Hole	Unformed Leads	Surface Mount
Channels	2	1	2	4	2
Common Channel Wiring	None	None	V _{CC} GND	V _{CC} GND	None

Agilent Part No. and Options

Commercial	4N55 ⁽¹⁾	HCPL-5500	HCPL-5530	HCPL-6550	HCPL-6530
MIL-PRF-38534 Class H	4N55/883B	HCPL-5501	HCPL-5531	HCPL-6551	HCPL-6531
MIL-PRF-38534 Class K	HCPL-257K	HCPL-550K	HCPL-553K	HCPL-655K	HCPL-653K
Standard Lead Finish	Gold Plate	Gold Plate	Gold Plate	Gold Plate	Solder Pads
Solder Dipped*	Option 200	Option 200	Option 200		
Butt Joint/Gold Plate	Option 100	Option 100	Option 100		
Gull Wing/Soldered*	Option 300	Option 300	Option 300		

Class H SMD Part #

Prescript for all below	5962-	5962-	5962-	5962-	5962-
Either Gold or Soldered	8767901EX	9085401HPX	8767902PX	8767904FX	87679032X
Gold Plate	8767901EC	9085401HPC	8767902PC	8767904FC	
Solder Dipped*	8767901EA	9085401HPA	8767902PA		87679032A
Butt Joint/Gold Plate	8767901UC	9085401HYC	8767902YC		
Butt Joint/Soldered*	8767901UA	9085401HYA	8767902YA		
Gull Wing/Soldered*	8767901TA	9085401HXA	8767902XA		

Class K SMD Part #

Prescript for all below	5962-	5962-	5962-	5962-	5962-
Either Gold or Soldered	8767905KEX	9085401KPX	8767906KPX	8767908KFX	8767907K2X
Gold Plate	8767905KEC	9085401KPC	8767906KPC	8767908KFC	
Solder Dipped*	8767905KEA	9085401KPA	8767906KPA		8767907K2A
Butt Joint/Gold Plate	8767905KUC	9085401KYC	8767906KYC		
Butt Joint/Soldered*	8767905KUA	9085401KYA	8767906KYA		
Gull Wing/Soldered*	8767905KTA	9085401KXA	8767906KXA		

1. JEDEC registered part.

* Solder contains lead

8 Pin Ceramic DIP Single Channel Schematic

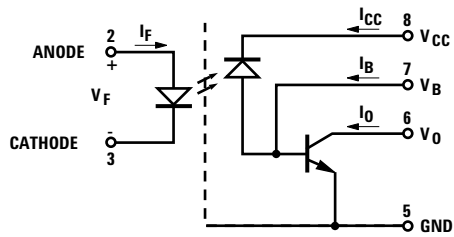

Note, base is pin 7.

Functional Diagrams

16 Pin DIP Through Hole 2 Channels	8 Pin DIP Through Hole 1 Channel	8 Pin DIP Through Hole 2 Channels	16 Pin Flat Pack Unformed Leads 4 Channels	20 Pad LCCC Surface Mount 2 Channels

Note: 8 pin DIP and flat pack devices have common V_{CC} and ground. 16 pin DIP and LCCC (leadless ceramic chip carrier) packages have isolated channels with separate V_{CC} and ground connections.

Outline Drawings

16 Pin DIP Through Hole, 2 Channels

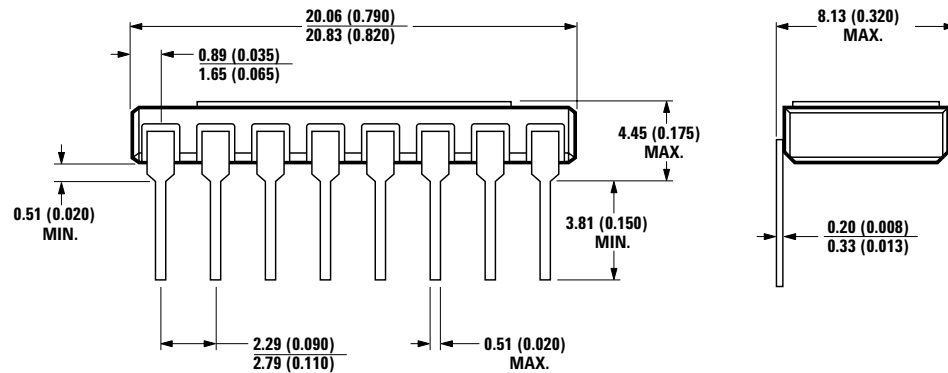

NOTE: DIMENSIONS IN MILLIMETERS (INCHES).

Leaded Device Marking

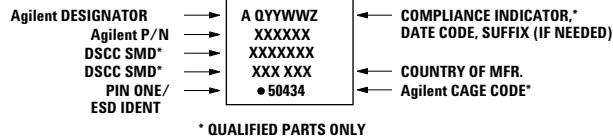

Leadless Device Marking

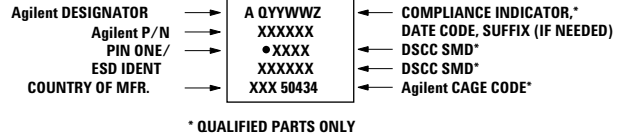

Outline Drawings

16 Pin Flat Pack, 4 Channels

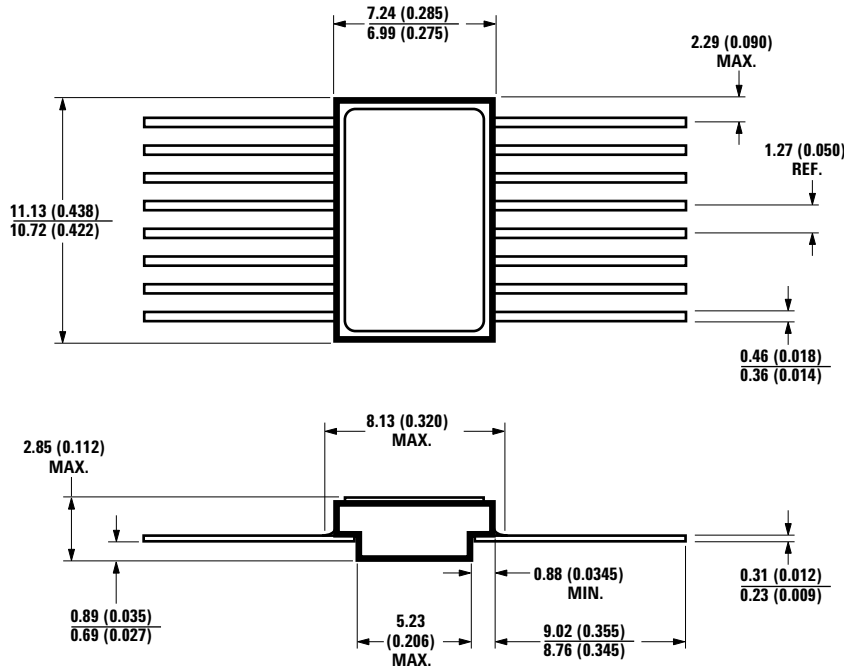

NOTE: DIMENSIONS IN MILLIMETERS (INCHES).

20 Terminal LCCC Surface Mount, 2 Channels

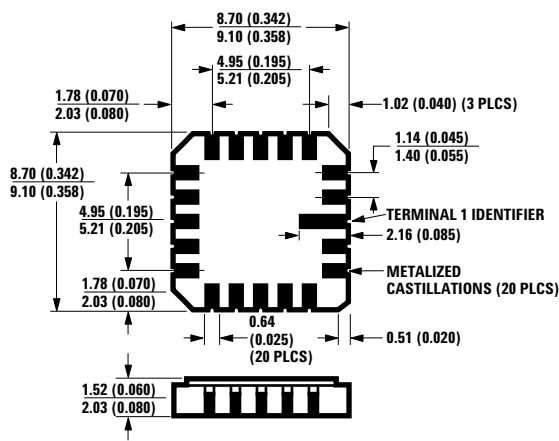

NOTE: DIMENSIONS IN MILLIMETERS (INCHES).
SOLDER THICKNESS 0.127 (0.005) MAX.

8 Pin DIP Through Hole, 1 and 2 Channel

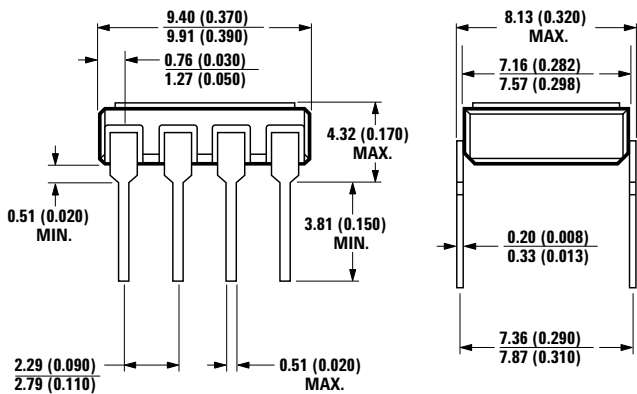

NOTE: DIMENSIONS IN MILLIMETERS (INCHES).

Hermetic Optocoupler Options

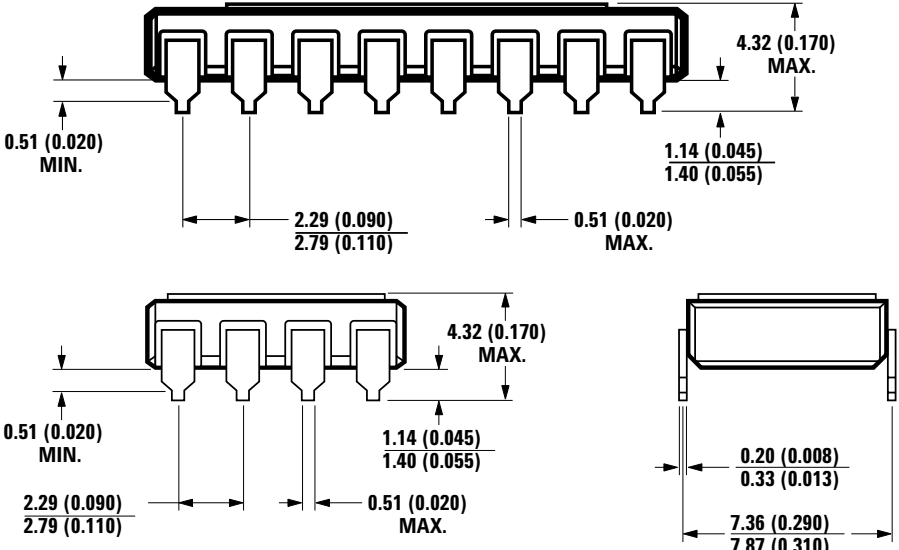
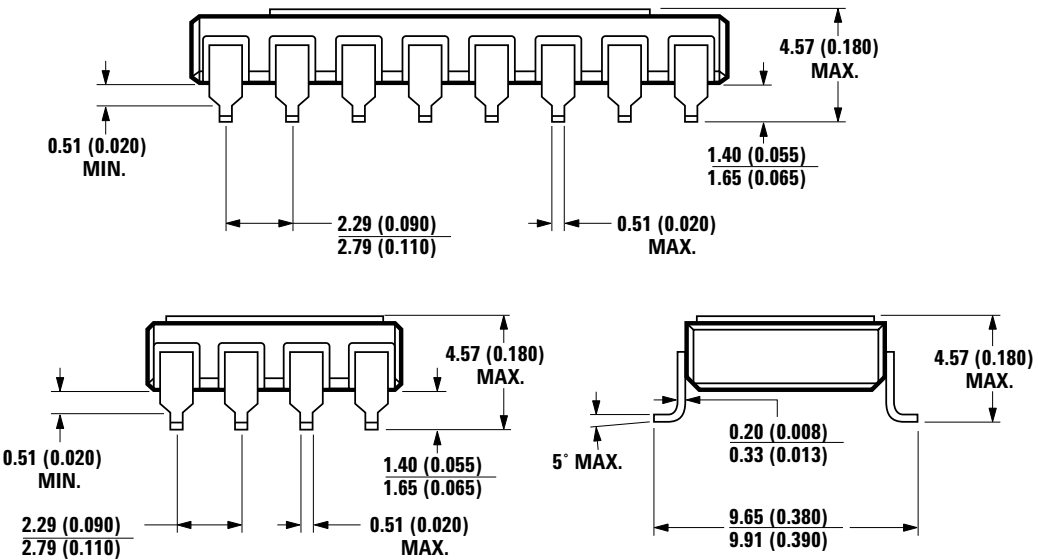
Option	Description
100	<p>Surface mountable hermetic optocoupler with leads trimmed for butt joint assembly. This option is available on commercial and hi-rel product in 8 and 16 pin DIP (see drawings below for details).</p>  <p style="text-align: center;">NOTE: DIMENSIONS IN MILLIMETERS (INCHES).</p>
200	<p>Lead finish is solder dipped rather than gold plated. This option is available on commercial and hi-rel product in 8 and 16 pin DIP. DSCC drawing part numbers contain provisions for lead finish. All leadless chip carrier devices are delivered with solder dipped terminals as a standard feature.</p>
300	<p>Surface mountable hermetic optocoupler with leads cut and bent for gull wing assembly. This option is available on commercial and hi-rel product in 8 and 16 pin DIP (see drawings below for details). This option has solder dipped leads.</p>  <p style="text-align: center;">NOTE: DIMENSIONS IN MILLIMETERS (INCHES).</p>

Absolute Maximum Ratings

No derating required up to +125° C.

Parameter	Symbol	Min.	Max.	Units
Storage Temperature Range	T_S	-65°	+150°	C
Operating Ambient Temperature	T_A	-55°	+125°	C
Junction Temperature	T_J		+175°	C
Case Temperature	T_C		+170°	C
Lead Solder Temperature (1.6 mm below seating plane)			260° for 10 s	C
Average Input Forward Current	$I_{F\text{ AVG}}$		20	mA
Peak Forward Input Current (each channel, ≤ 1 ms duration)	I_{FPK}		40	mA
Reverse Input Voltage	BV_R	See Electrical Characteristics		
Average Output Current, each channel	I_O		8	mA
Peak Output Current, each channel	I_O		16	mA
Supply Voltage	V_{CC}	-0.5	20	V
Output Voltage	V_O	-0.5	20	V
Input Power Dissipation, each channel			36	mW
Output Power Dissipation, each channel			50	mW
Package Power Dissipation, each channel	P_D		200	mW

Single Channel 8 Pin, Dual Channel 16 Pin, and LCCC Only

Emitter Base Reverse Voltage	V_{EBO}	3	V
Base Current, each channel	I_B	5	mA

ESD Classification

(MIL-STD-883, Method 3015)

4N55, 4N55/883B, HCPL-257K, HCPL-5500/01/0K, and HCPL-6530/31/3K	(▲), Class 1
HCPL-5530/31/3K, HCPL-6550/51/5K	(Dot), Class 3

Recommended Operating Conditions

Parameter	Symbol	Min.	Max.	Units
Input Current, Low Level	I_{FL}		250	μA
Input Current, High Level	I_{FH}	12	20	mA
Supply Voltage, Output	V_{CC}	2	18	V

Electrical Characteristics

$T_A = -55^\circ\text{C}$ to $+125^\circ\text{C}$, unless otherwise specified. See Note 12.

Parameter	Symbol	Group A, Sub-group	Test Conditions	Limits			Units	Fig.	Notes		
				Min.	Typ.*	Max.					
Current Transfer Ratio	CTR	1, 2, 3	$V_0 = 0.4\text{V}$, $I_F = 16\text{ mA}$, $V_{CC} = 4.5\text{V}$	9	20		%	2, 3	1, 2, 10		
Logic High Output Current	I_{OH}	1, 2, 3	$I_F = 0$, I_F (other channels) = 20 mA $V_0 = V_{CC} = 18\text{ V}$		5	100	μA	4	1		
Output Leakage Current	I_{OLeak}	1, 2, 3	$I_F = 250\ \mu\text{A}$, I_F (other channels) = 20 mA, $V_0 = V_{CC} = 18\text{ V}$		30	250	μA	4	1		
Input-Output Insulation Leakage Current	$I_{I,O}$	1	$V_{I,O} = 1500\text{ Vdc}$, $RH \leq 65\%$, $T_A = 25^\circ\text{C}$, $t = 5\text{ s}$			1.0	μA		3, 9		
Input Forward Voltage	V_F	1, 2, 3	$I_F = 20\text{ mA}$		1.55	1.8	V	1	1, 14		
						1.9			1, 13		
Reverse Breakdown Voltage	BV_R	1, 2, 3	$I_R = 10\ \mu\text{A}$		5		V		1, 14		
					3				1, 13		
Logic High Supply Current	Single Channel	I_{CCH}	1, 2, 3	$V_{CC} = 18\text{ V}$, $I_F = 0\text{ mA}$		0.1	10	μA		1	
	Dual Channel						0.2			20	1, 4
	Quad Channel						0.4			40	1
Logic Low Supply Current	Single Channel	I_{CCL}	1, 2, 3	$V_{CC} = 18\text{ V}$, $I_F = 20\text{ mA}$		35	200	μA		1	
	Dual Channel						70			400	1, 4
	Quad Channel						140			800	1
Propagation Delay Time to Logic High at Output	t_{PLH}	9, 10, 11		$R_L = 8.2\text{ k}\Omega$, $C_L = 50\text{ pF}$, $I_F = 16\text{ mA}$, $V_{CC} = 5\text{ V}$		1.0	6.0	μs	6, 9	1, 6	
Propagation Delay Time to Logic Low at Output	t_{PHL}						0.4				2.0

*All typical values are at $V_{CC} = 5\text{ V}$, $T_A = 25^\circ\text{C}$.

Typical Characteristics

All typical values are at $T_A = 25^\circ\text{C}$, $V_{CC} = 5\text{ V}$, unless otherwise specified.

Parameter	Symbol	Test Conditions	Typ.	Units	Fig.	Notes
Input Capacitance	C_{IN}	$V_F = 0\text{ V}$, $f = 1\text{ MHz}$	60	pF		1
Input Diode Temperature Coefficient	$\Delta V_F/\Delta T_A$	$I_F = 20\text{ mA}$	-1.5	mV/ $^\circ\text{C}$		1
Resistance (Input-Output)	R_{I-O}	$V_{I-O} = 500\text{ V}$	10^{12}	Ω		3
Capacitance (Input-Output)	C_{I-O}	$f = 1\text{ MHz}$	1.0	pF		1, 11
Transistor DC Current Gain	h_{FE}	$V_O = 5\text{ V}$, $I_O = 3\text{ mA}$	250	-		1
Small Signal Current Transfer Ratio	$\Delta I_O/\Delta I_F$	$V_{CC} = 5\text{ V}$, $V_O = 2\text{ V}$	21	%	7	1
Common Mode Transient Immunity at Logic High Level Output	$ CM_H $	$I_F = 0\text{ mA}$, $R_L = 8.2\text{ k}\Omega$, $V_O(\text{min}) = 2.0\text{ V}$, $V_{CM} = 10\text{ V}_{P-P}$	1000	V/ μs	10	1, 7
Common Mode Transient Immunity at Logic Low Level Output	$ CM_L $	$I_F = 16\text{ mA}$, $R_L = 8.2\text{ k}\Omega$, $V_O(\text{max}) = 0.8\text{ V}$, $V_{CM} = 10\text{ V}_{P-P}$	-1000	V/ μs	10	1, 7
Bandwidth	BW		9	MHz	8	8

Multi-Channel Product Only

Parameter	Symbol	Test Conditions	Typ.	Units	Notes
Input-Input Insulation Leakage Current	I_{I-I}	$RH \leq 65\%$, $V_{I-I} = 500\text{ V}$, $t = 5\text{ s}$	1	pA	5, 9
Resistance (Input-Input)	R_{I-I}	$V_{I-I} = 500\text{ V}$	10^{12}	Ω	5
Capacitance (Input-Input)	C_{I-I}	$f=1\text{ MHz}$	0.8	pF	5

Notes:

- Each channel of a multi-channel device.
- Current Transfer Ratio is defined as the ratio of output collector current, I_O , to the forward LED input current, I_F , times 100%. CTR is known to degrade slightly over the unit's lifetime as a function of input current, temperature, signal duty cycle, and system on time. Refer to Application Note 1002 for more detail. In short, it is recommended that designers allow at least 20-25% guardband for CTR degradation.
- All devices are considered two-terminal devices; measured between all input leads or terminals shorted together and all output leads or terminals shorted together.
- The 4N55, 4N55/883B, HCPL-257K, HCPL-6530, HCPL-6531, and HCPL-653K dual channel parts function as two independent single channel units. Use the single channel parameter limits. $I_F = 0\text{ mA}$ for channel under test and $I_F = 20\text{ mA}$ for other channels.
- Measured between adjacent input pairs shorted together for each multichannel device.
- t_{PHL} propagation delay is measured from the 50% point on the leading edge of the input pulse to the 1.5 V point on the leading edge of the output pulse. The t_{PLH} propagation delay is measured from the 50% point on the trailing edge of the input pulse to the 1.5 V point on the trailing edge of the output pulse.
- CM_L is the maximum rate of rise of the common mode voltage that can be sustained with the output voltage in the logic low state ($V_O < 0.8\text{ V}$). CM_H is the maximum rate of fall of the common mode voltage that can be sustained with the output voltage in the logic high state ($V_O > 2.0\text{ V}$).
- Bandwidth is the frequency at which the ac output voltage is 3 dB below the low frequency asymptote. For the HCPL-5530 the typical bandwidth is 2 MHz.
- This is a momentary withstand test, not an operating condition.
- Higher CTR minimums are available to support special applications.
- Measured between each input pair shorted together and all output connections for that channel shorted together.
- Standard parts receive 100% testing at 25°C (Subgroups 1 and 9). SMD and 883B parts receive 100% testing at 25, 125, and -55°C (Subgroups 1 and 9, 2 and 10, 3 and 11, respectively).
- Not required for 4N55, 4N55/883B, HCPL-257K, 5962-8767901, and 5962-8767905 types.
- Required for 4N55, 4N55/883B, HCPL-257K, 5962-8767901, and 5962-8767905 types only.

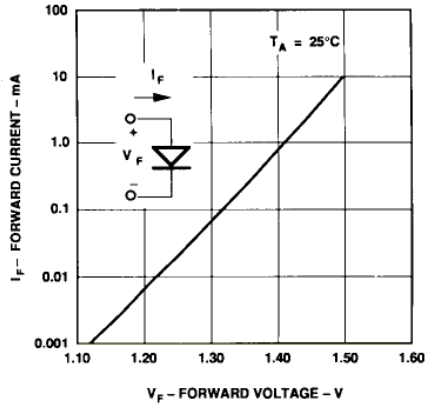

Figure 1. Input Diode Forward Current vs. Forward Voltage.

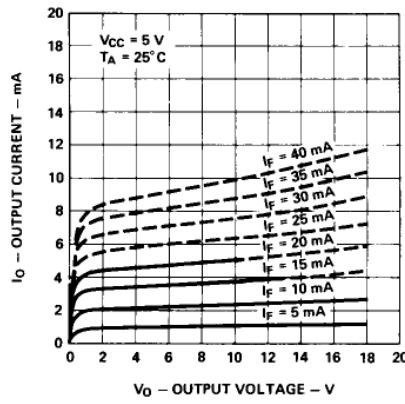

Figure 2. DC and Pulsed Transfer Characteristic.

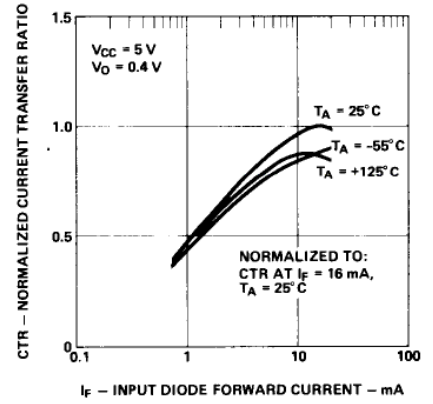

Figure 3. Normalized Current Transfer Ratio vs. Input Diode Forward Current.

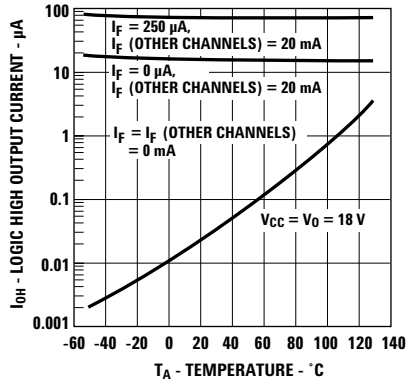

Figure 4. Logic High Output Current vs. Temperature.

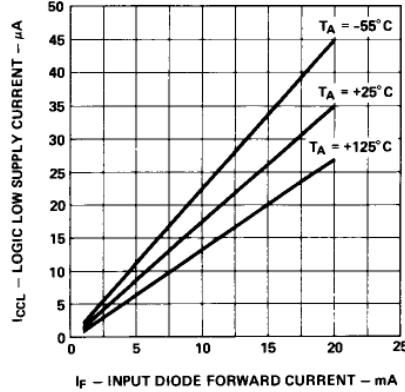

Figure 5. Logic Low Supply Current vs. Input Diode Forward Current.

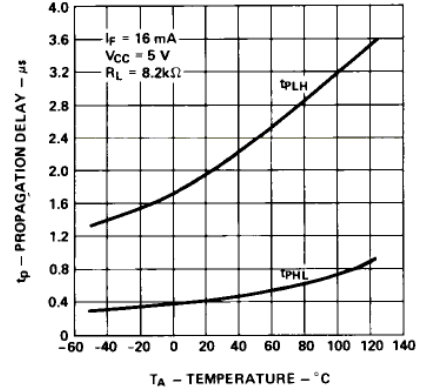

Figure 6. Propagation Delay vs. Temperature.

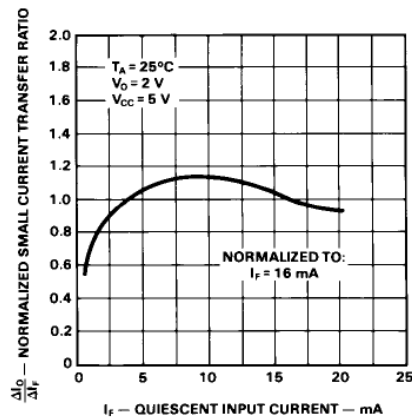

Figure 7. Normalized Small Signal Current Transfer Ratio vs. Quiescent Input Current.

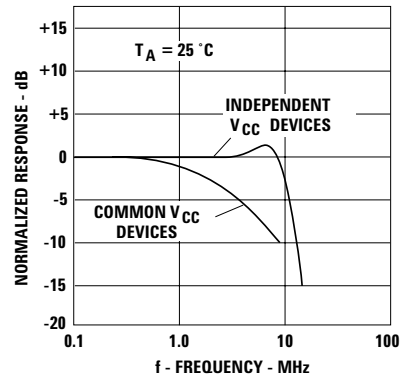
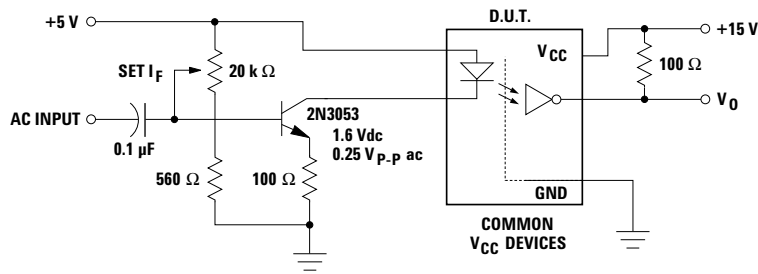
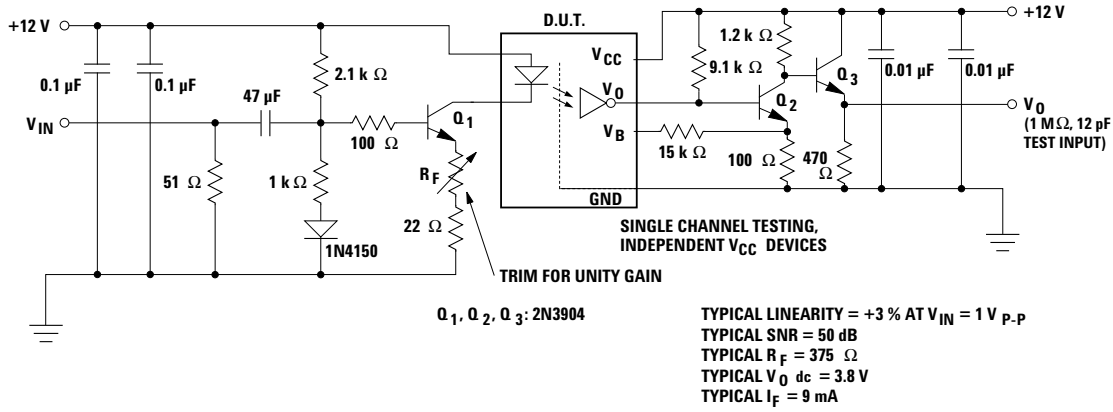
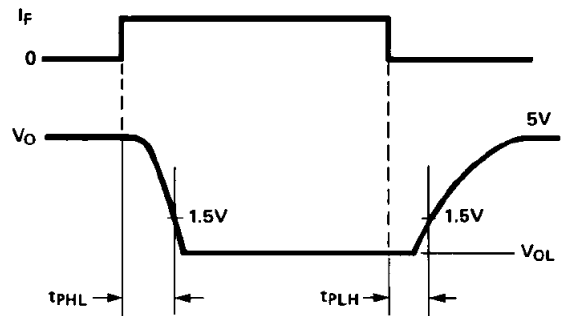
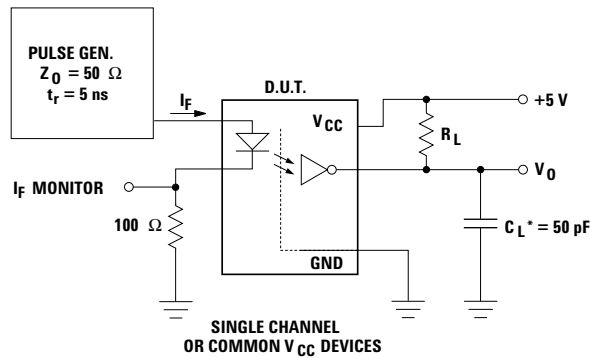

Figure 8. Frequency Response.



10% DUTY CYCLE
 $1/f < 100 \mu s$

NOTES:
 * C_L INCLUDES PROBE AND STRAY WIRING CAPACITANCE.
 BASE LEAD NOT CONNECTED.

Figure 9. Switching Test Circuit.*

*JEDEC Registered Data.

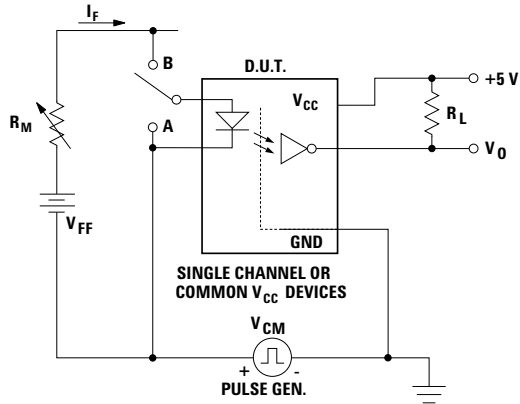

NOTE: BASE LEAD NOT CONNECTED.

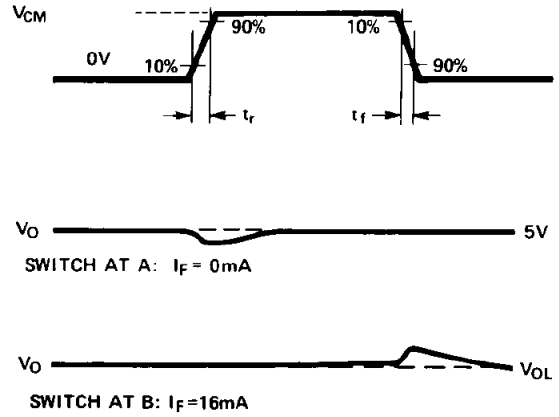
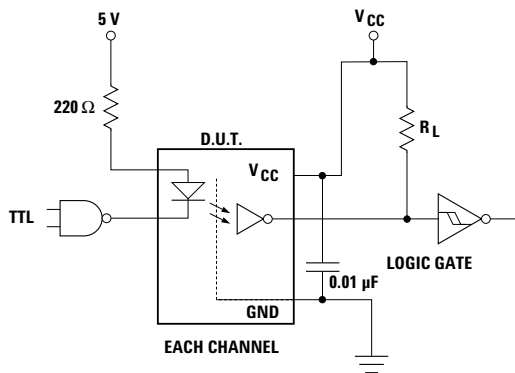

Figure 10. Test Circuit for Transient Immunity and Typical Waveforms.



Logic Family	LSTTL	CMOS	
Device No.	54LS14	CD40106BM	
V _{CC}	5 V	5 V	15 V
R _L 5% Tolerance	18 kΩ *	8.2 kΩ	22 kΩ

*The equivalent output load resistance is affected by the LSTTL input current and is approximately 8.2 kΩ. This is a worst case design which takes into account 25% degradation of CTR. See App. Note 1002 to assess actual degradation and lifetime.

Figure 11. Recommended Logic Interface.

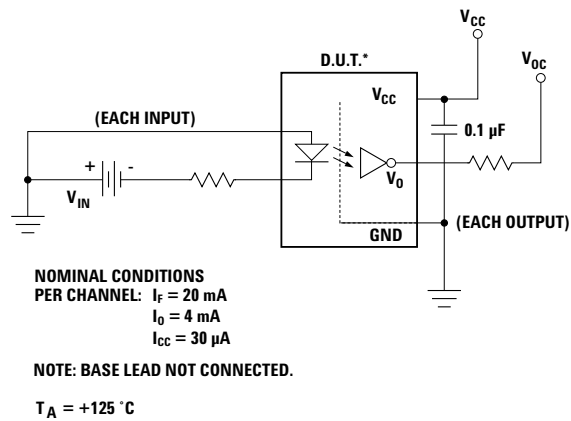

Figure 12. Operating Circuit for Burn-In and Steady State Life Tests. All Channels Tested Simultaneously.

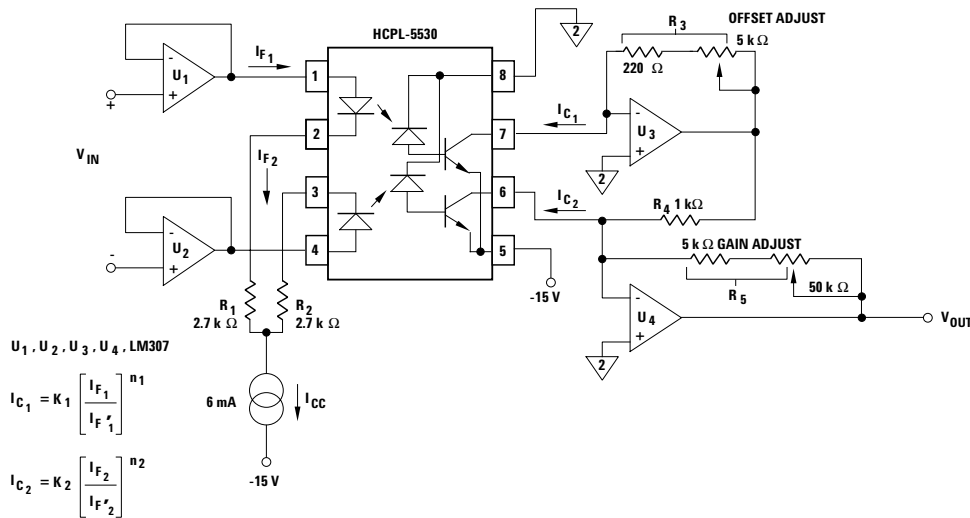

Figure 13. Isolation Amplifier Application Circuit.

Description

The schematic uses a dualchannel, high-speed optocoupler (HCPL-5530) to function as a servo type dc isolation amplifier. This circuit operates on the principle that two optocouplers will track each other if their gain changes by the same amount over a specific operating region.

Performance of Circuit

- 1% linearity for 10 V peak-to-peak dynamic range
- Gain drift: -0.03%/°C
- Offset Drift: ± 1 mV/°C
- 25 kHz bandwidth (limited by Op-Amps U1, U2)

MIL-PRF-38534 Class H, Class K, and DSCC SMD Test Program

Agilent's Hi-Rel Optocouplers are in compliance with MIL-PRF-38534 Classes H and K. Class H and Class K devices are also in compliance with DSCC drawings 5962-87679, and 5962-90854. Testing consists of 100% screening and quality conformance inspection to MIL-PRF-38534.

**www.agilent.com/
semiconductors**

For product information and a complete list of distributors, please go to our web site.

For technical assistance call:

Americas/Canada: +1 (800) 235-0312
or (408) 654-8675

Europe: +49 (0) 6441 92460

China: 10800 650 0017

Hong Kong: (+65) 6756 2394

India, Australia, New Zealand: (+65) 6755 1939

Japan: (+81 3) 3335-8152(Domestic/International), or 0120-61-1280(Domestic Only)

Korea: (+65) 6755 1989

Singapore, Malaysia, Vietnam, Thailand, Philippines, Indonesia: (+65) 6755 2044

Taiwan: (+65) 6755 1843

Data subject to change.

Copyright © 2004 Agilent Technologies, Inc.

December 10, 2004

5989-1659EN



Agilent Technologies