

R192P OC-192/STM-64 Lightwave Receiver with Improved Sensitivity (-18 dBm)



Featuring improved sensitivity for optimum performance in noisy, amplified systems, the R192P Receiver is manufactured in a compact, 16-pin surface-mount package (above), and is also available with a convenient mounting bracket (below).



Features

- High data rate capability, 10.7 Gbits/s
- PIN photodetector
- Fully operational through the 1.3 μm to 1.6 μm wavelength range
- Improved typical sensitivity of -18 dBm
- Single-mode fiber pigtail with ST[®], SC, LC, or FC/PC optical connector
- Operating case temperature range:
0 °C to 70 °C
- 50 Ω differential data output, with offset control
- Package options:
 - Space-sensitive package without mounting bracket (ideal for transponder and transceiver applications)
 - With mounting bracket

Applications

- Line terminal equipment
- High-speed networks up to 10.7 Gbits/s
- SONET/SDH OC-192/STM-64 telecommunications applications
- Extended-reach datacom and telecom applications

Description

Receiver Operation

The R192P 10.7 Gbits/s fiber-optic receiver consists of a high-speed PIN photodetector and a wide-band linear preamp in a pigtailed, surface-mount metal package. It is designed for use in single-mode, high-speed telecommunication applications at the SONET OC-192 and the ITU-T SDH STM-64 data rate of 9.95328 Gbits/s.

At 10.7 Gbits/s, the typical room temperature sensitivity measured at a BER of 1×10^{-10} is –17 dBm. The operating case temperature range for the receiver is 0 °C to 70 °C.

The receiver is manufactured in a compact, 16-pin surface-mount package with a single-mode optical fiber pigtail. The fiber pigtail is internally beveled for low return loss and is available with *ST*, *SC*, *LC*, or *FC-PC* optical connectors.

The dc levels of the differential outputs can be adjusted relative to each other for optimum sensitivity in noisy, amplified systems. These outputs are centered around a dc level of typically –0.45 V. The TIA requires only a –5 V power supply for operation. The PIN photodiode requires a nominal bias voltage of 5 V to 10 V at less than 1 mA.

Pin Information

Table 1. Pin Descriptions

Pin Number	Name
1	PIN Bias
2	GND
3	VEE
4	NC
5	NC
6	NC
7	GND
8	DATAN
9	DATA
10	GND
11	NC
12	–OFF
13	+OFF
14	Feedback Input Threshold Control
15	GND
16	Thermistor

Absolute Maximum Ratings

Stresses in excess of the absolute maximum ratings can cause permanent damage to the device. These are absolute stress ratings only. Functional operation of the device is not implied at these or any other conditions in excess of those given in the operations section of the data sheet. Exposure to absolute maximum ratings for extended periods can adversely affect device reliability.

Parameter	Symbol	Min	Max	Unit
Supply Voltages: Negative Supply	VEE	–4.7	–5.7	V
Photodiode Supply Current: Forward*	—	—	20	mA
Reverse	—	—	2	mA
Optical Input Power	P _{MAX}	—	8	dBm
Operating Case Temperature	T _C	0	85	°C
Storage Temperature	T _C	–40	100	°C
Lead Soldering Temperature	—	—	250	°C
Lead Soldering Time	—	—	10	s

* Device is normally reverse biased. Forward biasing the photodiode can compromise device performance and reliability.

Optical Characteristics

Table 2. Optical Characteristics (T_A = 25 °C)

Parameter	Symbol	Min	Typ	Max	Unit
Optical Wavelength	λ	1.250	—	1.615	μm
Sensitivity (10.7 Gbits/s, 2 ²³ – 1 PRBS, 1 x 10 ^{–10} BER, 1310 nm < λ < 1550 nm)	P _{LOW}	—	–18	–17	dBm
Maximum Optical Input Power (10.7 Gbits/s, 2 ²³ – 1 PRBS, 1 x 10 ^{–10} BER), V _{PIN} = 5 V	P _{HIGH}	0	1	—	dBm
Optical Return Loss	—	—	–30	–27	dB
Responsivity of PIN, λ = 1.55 μm	R _{PIN}	0.7	0.8	—	A/W
Total Dark Current	I _D	—	0.3	—	nA

Electrical Characteristics

Table 3. Electrical Characteristics (TA = 25 °C)

Parameter	Symbol	Min	Typ	Max	Unit
dc Power Supply Voltages:					
Negative Supply	VEE	–4.94	–5.2	–5.46	V
PIN Bias	VPIN	5	9	13	V
dc Power Supply Currents:					
Negative Supply	IEE	—	80	110	mA
PIN Bias	IPIN	—	—	2	mA
Power Dissipation	PDISS	—	—	0.6	W
Transimpedance:* IPH ≤ 500 μA	TZ	550	700	900	Ω
Note: The output voltage increases linearly up to 750 μAp-p of input current and is operational up to 2.2 mAp-p of input current. Conditions: single-ended, 50 Ω load, low frequency.					
Average Equivalent Input Noise Spectral Density (Bandwidth 100 KHz to 15 GHz)	—	—	14	—	pA/√Hz
Summed Equivalent Noise Power	—	—	1400	—	nArms
Low Frequency Cutoff	fL	—	25	—	kHz
Bandwidth	BW	8.5	10	—	GHz
Rolloff (F3 dB to F3 dB + 5 GHz)	—	—	–20	—	dB
Peaking	—	—	2	—	dB
Group Delay:	—				
0.2 GHz—5 GHz		—	±15	—	ps
0.2 GHz—8 GHz		—	±20	—	ps
Output Return Loss:	S22				
0 GHz—6 GHz		—	>10	—	dB
0 GHz—8 GHz		—	>8	—	dB

*Transimpedance, $TZ = \frac{V_{PP}}{I_{PH(AVG)}}$, where $I_{PH(AVG)}$ = the average photodiode current.

Outline Diagrams

Outline Drawing, Package Style A

Dimensions are in inches and (millimeters).

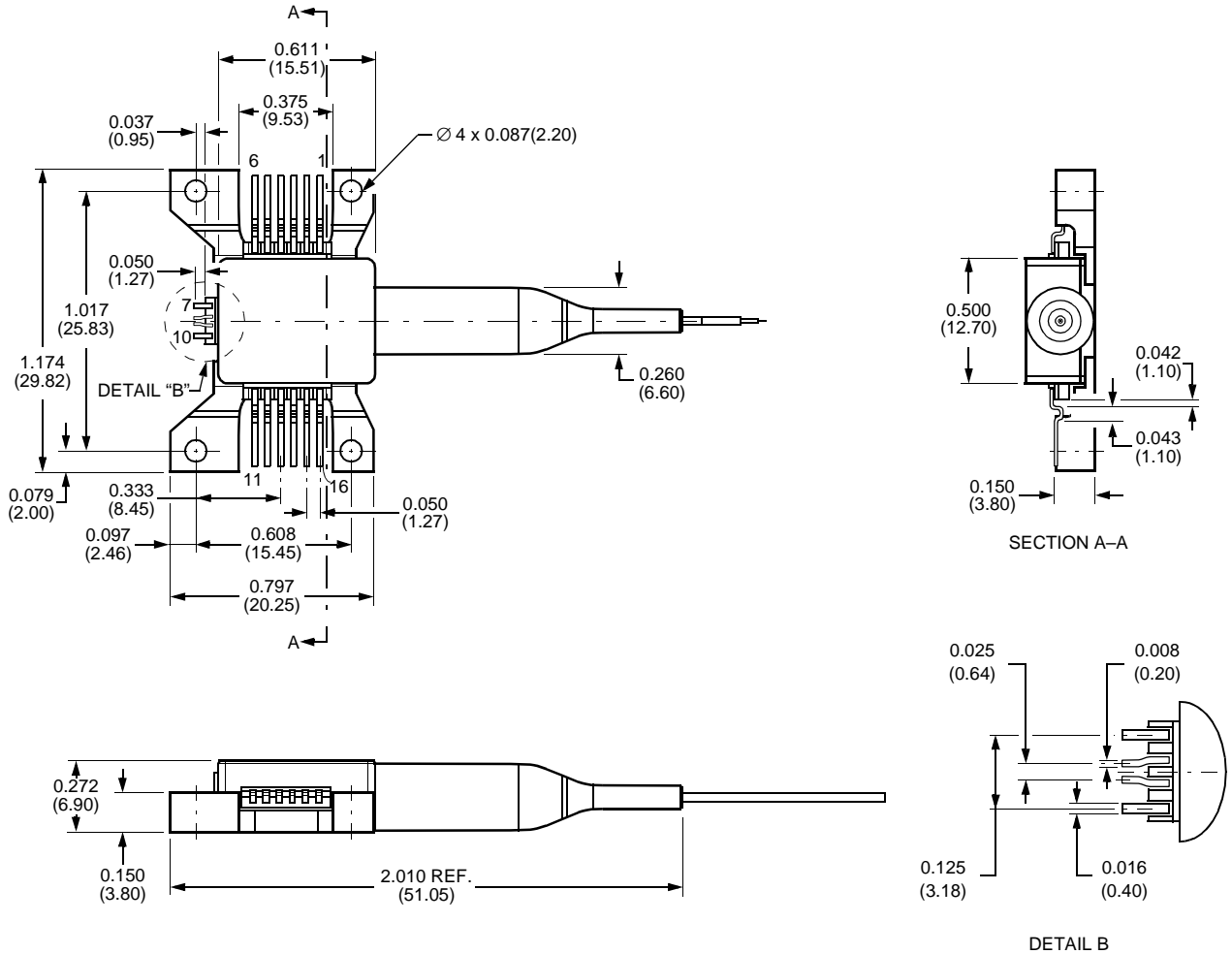

1-1237(F)

Outline Diagrams (continued)

Outline Drawing, Package Style N

Dimensions are in inches and (millimeters).

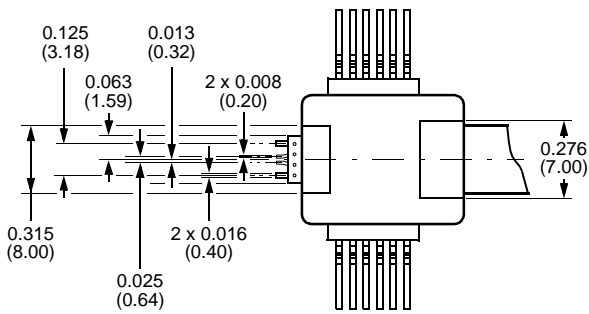
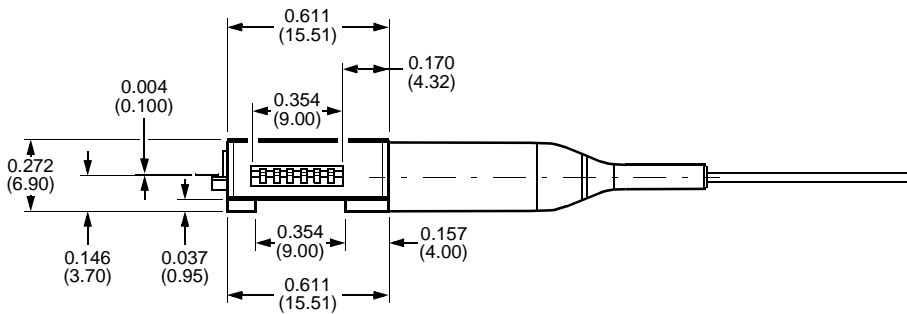
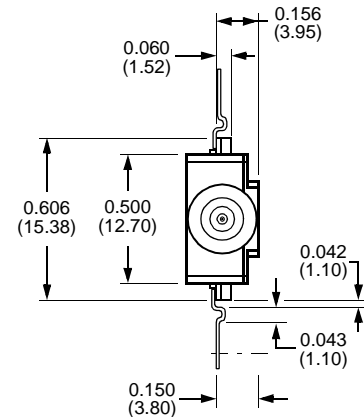
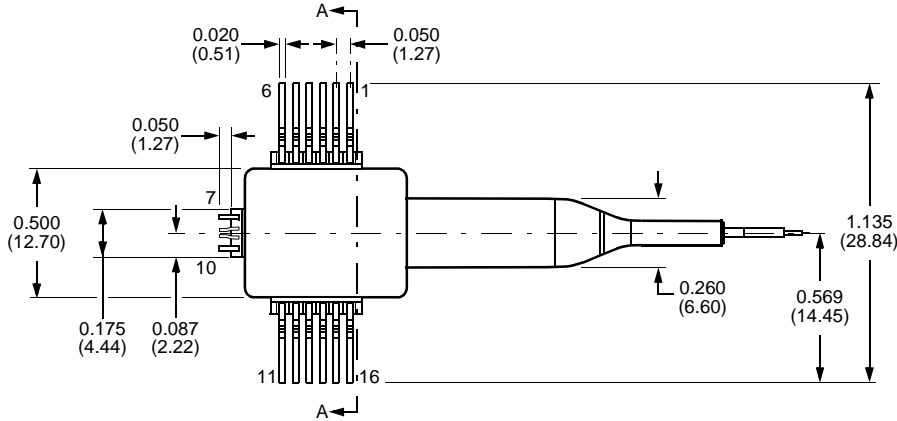

1-1236(F)

Ordering Information

Table 4. Ordering Information¹

Description	Product Code	Package Style	Connector	Comcode
R192P-Type OC-192/STM-64 Lightwave Receiver	R192PDAA	A	SC	108668815
	R192PGAA	A	FC	108668849
	R192PSAA	A	LC	108989435
	R192PDAN	N	SC	108940412
	R192PSAN	N	LC	108989443

1. For additional ordering information, please contact an Agere Systems account manager at Opto West, 1-800-362-3891 (for sales staff, please press option 2).

For additional information, contact your Agere Systems Account Manager or the following:

INTERNET: <http://www.agere.com>

E-MAIL: docmaster@micro.lucent.com

N. AMERICA: Agere Systems Inc., 555 Union Boulevard, Room 30L-15P-BA, Allentown, PA 18109-3286

1-800-372-2447, FAX 610-712-4106 (In CANADA: **1-800-553-2448**, FAX 610-712-4106)

ASIA PACIFIC: Agere Systems Singapore Pte. Ltd., 77 Science Park Drive, #03-18 Cintech III, Singapore 118256

Tel. (65) 778 8833, FAX (65) 777 7495

CHINA: Agere Systems (Shanghai) Co., Ltd., 33/F Jin Mao Tower, 88 Century Boulevard Pudong, Shanghai 200121 PRC

Tel. (86) 21 50471212, FAX (86) 21 50472266

JAPAN: Agere Systems Japan Ltd., 7-18, Higashi-Gotanda 2-chome, Shinagawa-ku, Tokyo 141, Japan

Tel. (81) 3 5421 1600, FAX (81) 3 5421 1700

EUROPE: Data Requests: DATALINE: **Tel. (44) 7000 582 368**, FAX (44) 1189 328 148

Technical Inquiries: OPTOELECTRONICS MARKETING: **(44) 1344 865 900** (Ascot UK)

Agere Systems Inc. reserves the right to make changes to the product(s) or information contained herein without notice. No liability is assumed as a result of their use or application. *ST* is a registered trademark of Agere Systems Inc.