

# ARX5001 & ARX5002

## ARX LOW NOISE DC VOLTAGE REGULATORS

(Preliminary)



### Features

- Low Noise,  $20\text{NV}/\sqrt{\text{Hz}}$  @10KHz, Typical
- Superior High Frequency Line Transient and Input Ripple Rejection
- Full Military Temperature Range, Built to Military Standards
- State of the Art Power Density, Smallest Possible Surface Area
- Load Current Range up to 2 Amperes
- Total Worst Case Line & Load Voltage Regulation,  $\leq \pm 1\%$
- Internal Short Circuit and Current Fold Back Protection
- Available in Standard DC Voltages: +15V & +5V

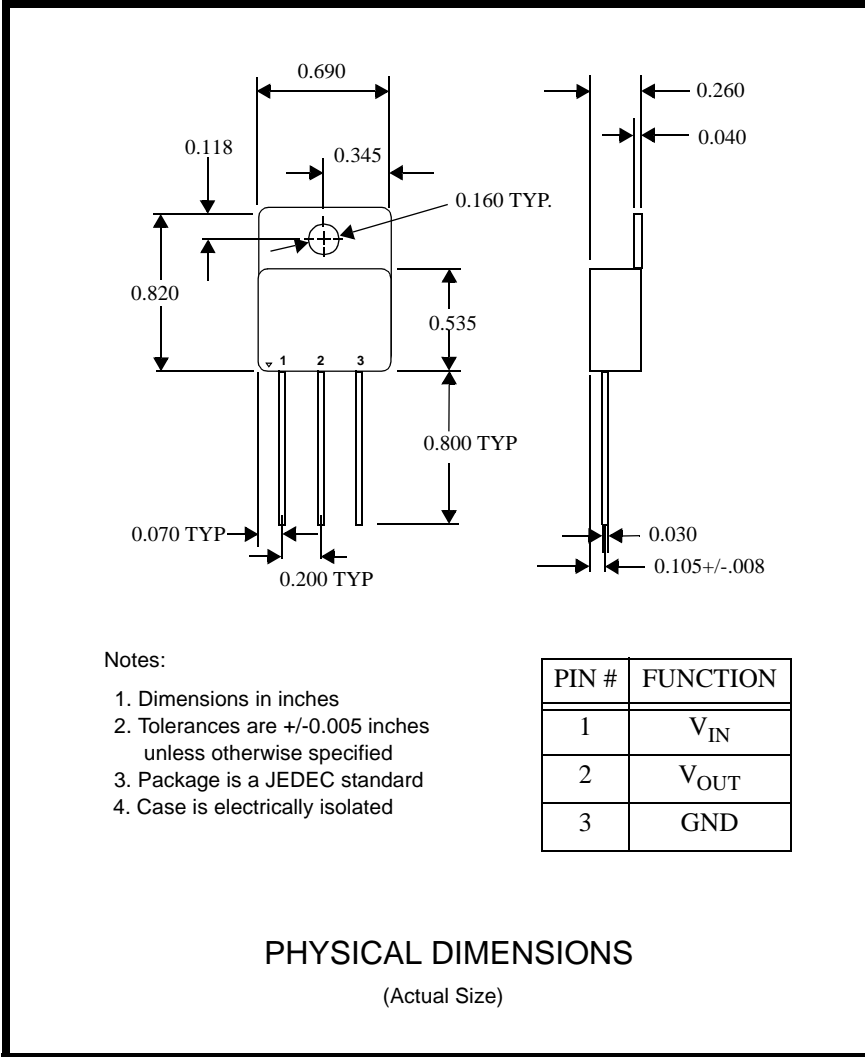

PIN #	FUNCTION
1	V <sub>IN</sub>
2	V <sub>OUT</sub>
3	GND

### Description

The ARX series of low noise DC voltage regulators is a new line of ultra highly reliable microcircuits designed for military and aerospace applications. These regulators utilize advanced multichip module design techniques to provide state-of-the-art performance features with no sacrifice in reliability.

The ARX series regulators can be used in applications where minimum size and maximum output power is required. These regulators are designed to operate over the full military operating case temperature range of -55°C to +125°C.

Outstanding high frequency ripple rejection, input overshoot rejection and input noise rejection are features of the ARX series that are not available from monolithic regulators.

To provide protection against output overloads, current limiting and reduced current foldback short circuit protection are standard.

**Table 1 – Electrical Characteristics**

Part Number (Nominal Voltage)		ARX5002 (+15V)			ARX5001 (+5V)			Units
Parameter	Conditions (unless otherwise noted) $T_A = -55^\circ\text{C to } +125^\circ\text{C}$	Min	Nom	Max	Min	Nom	Max	
Input Voltage	Maximum load current	18	-	23	8	-	15	VDC
	No load current	-	-	30	-	-	30	VDC
Output Voltage	Maximum load current	14.85	15.00	15.15	4.95	5.00	5.05	VDC
Load Current	Minimum Input voltage	-	-	1.8	-	-	1.8	ADC
Line Regulation	Delta input voltage = 3V Maximum load current	-	20	50	-	1	10	mVDC
Load Regulation	Full load to no load current	-	-	100	-	35	50	mVDC
Short Circuit Trip Current	Minimum Input voltage	2	-	3.5	2	-	3.5	ADC
Short Circuit Foldback Current	Minimum Input voltage	0.10	0.20	0.40	0.10	0.20	0.30	ADC
Ripple Rejection	$0 \leq f \leq 150\text{kHz}$ , $I_L = 900\text{ mA}$	40	-	-	40	-	-	dB
Output Spot Noise	$T_A = +25^\circ\text{C}$ , $V_{IN} = \text{minimum}$ $10\text{ kHz}$ , $I_L = 900\text{ mA}$	-	-	40	-	-	30	$\text{NV}/\sqrt{\text{Hz}}$

Notes: 1. Maximum power dissipation is limited to 10 Watts at 125°C case temperature  
 2. Custom voltage and short circuit trip current settings are available on special order

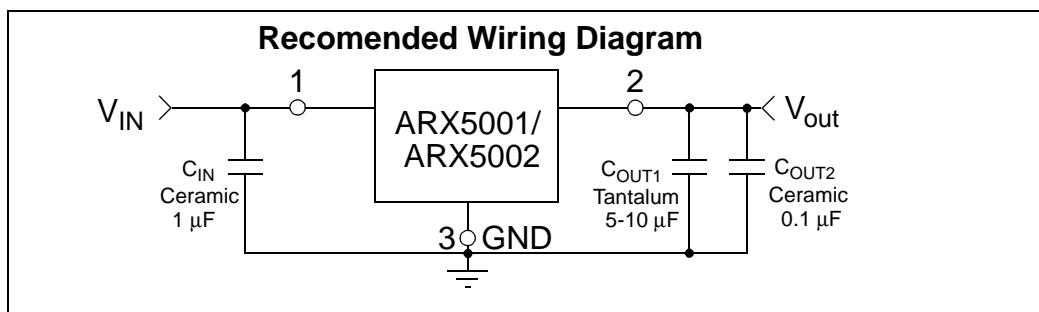

**Ordering Information**

**ARX5001 +5 Volts**  
**ARX5002 +15 Volts**

**AEROFLEX**  
 Circuit Technology  
 35 South Service Road  
 Plainview N.Y. 11803  
 Tele: (516) 694-6700  
 Fax: (516) 694-6715