

**ANALOG  
DEVICES****Advanced Video Decoder with 9-Bit ADC,  
& Component Input Support****ADV7183****FEATURES**

**Analog Video to Digital YUV Video Decoder**  
 NTSC-(M/N), PAL-(B/D/G/H/I/M/N)  
**Integrates Two 9-Bit Accurate ADCs**  
**Clocked from a Single 27 MHz Crystal**  
**Dual Video Clocking Schemes**  
 Line Locked Clock Compatible (LLC)  
 Fixed Frequency Oversampling 10-Bit Operation  
**Adaptive-Digital-Line-Length-Tracking (ADLLT™)**  
**Real Time Clock & Status Information Output**  
**Integrated AGC (Automatic Gain Control) & Clamping**  
**Simplified Digital Interface**  
**On-Board Digital FIFO**  
**Optimised Programmable Video Source Modes**  
 Broadcast TV  
 VCR/Camcorder  
 Security/Surveillance  
**Multiple, Programmable Analog Input Formats:**  
 CVBS (Composite Video)  
 SVHS (Y/C)  
 YPrPb or YUV  
**6 Analog Input Video Channels**  
**2 Line Chroma Comb Filter**  
**Automatic NTSC/PAL Identification**  
**VMI & VIP compliant video pixel port**  
**Digital Output Formats (16-Bit Wide Bus):**

YCrCb (4:2:2 or 4:1:1)  
 CCIR601/CCIR656 8-Bit  
 0.5V to 2.0V pk-pk i/p range  
 Differential Gain typ 1%  
 Differential Phase typ 1°  
**Programmable Video Controls**  
 Pk-White/Hue/Brightness/Saturation/Contrast  
**CCIR/Square Pixel Operation**  
**Integrated On-Chip Video Timing Generator**  
**Synchronous or Asynchronous Output Timing**  
**Line Locked Clock Output**  
**Close Captioning Passthrough Operation**  
**Vertical Blanking Interval Support**  
**Power Down Mode**  
**2-Wire Serial MPU Interface (I<sup>2</sup>C Compatible)**  
**+5V Analog +3.3V Digital CMOS Supply Operation**  
**80-Pin LQFP Package**

**APPLICATIONS**

**DVD-RAM or DVD-R**  
**Digital TV's**  
**Video Conferencing**  
**Hybrid Analog/Digital Set Top Boxes**  
**PC Video/Multimedia**  
**Camcorders**  
**Security Systems/Surveillance**

**GENERAL DESCRIPTION**

The ADV7183 is an integrated video decoder that automatically recognises and converts a standard analog baseband television signal compatible with world wide standards NTSC or PAL into 4:2:2 or 4:1:1 component video data compatible with 16-bit/8-Bit CCIR601/CCIR656 8-Bit standards.

The advanced and highly flexible digital output interface enables performance video decoding and conversion in both frame-buffer based and line locked clock based systems. This makes the device ideally suited for a broad range of applications with diverse analog video characteristics including tape based sources, broadcast sources, security/surveillance cameras and professional systems.

Fully integrated line stores enable real time horizontal and vertical scaling of captured video down to icon size. The 9-bit accurate A/D conversion provides professional quality SNR performance. This allows true 8-bit resolution in the 8-bit output mode.

Rev. PrF 09/01

Information furnished by Analog Devices is believed to be accurate and reliable. However, no responsibility is assumed by Analog Devices for its use, nor for any infringements of patents or other rights of third parties which may result from its use. No license is granted by implication or otherwise under any patent or patent rights of Analog Devices.

The 6 analog inputs channel accept standard composite, S-Video and Component YPrPb video signals in an extensive number of combinations. AGC and Clamp Restore circuitry allow an input video signal peak to peak range of 0.5V up to 2V. Alternatively these can be bypassed for manual settings.

The fixed 27 MHz clocking of the ADCs and datapath for all modes allows very precise and accurate sampling and digital filtering. The Line Locked Clock output allows the output data rate, timing signals and output clock signals to be synchronous, asynchronous or line locked even with +/-5% line length variation. The output control signals allow glueless interface connection in almost any application.

The ADV7183 modes are set up over a two wire serial bidirectional port (I<sup>2</sup>C compatible).

The ADV7183 is fabricated in a +5V CMOS process. Its monolithic CMOS construction ensures greater functionality with lower power dissipation.

The ADV7183 is packaged in a small 80 pin LQFP package.

\* ADV is a Registered Trademark of Analog Devices, Inc.

**One Technology Way, P.O. Box 9106, Norwood, MA 02062-9106, U.S.A.**  
**Tel: 617/329-4700 World Wide Web Site: <http://www.analog.com>**  
**Fax: 617/326-8703 © Analog Devices, Inc.,**

# ADV7183

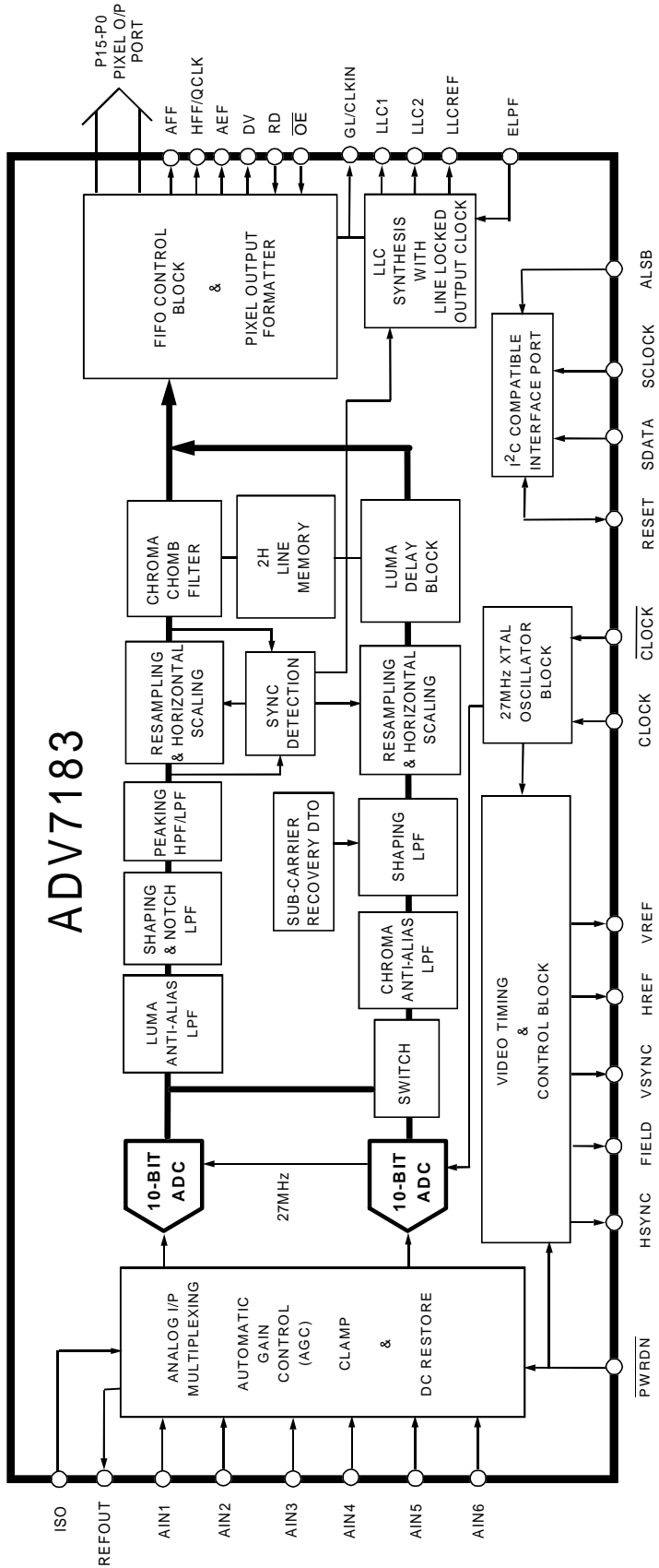

ADV7183

FUNCTIONAL BLOCK DIAGRAM

# PRELIMINARY TECHNICAL DATA

# ADV7183

## PIN DESCRIPTION

Mnemonic	Input/Output	Function
P15-P0	O	Video pixel output port. 8-Bit Multiplexed YCrCb Pixel Port (P15-P8), 16-Bit YCrCb Pixel Port (P15-P8=Y & P7-P0=Cb,Cr).
GPO[0:3]	O	General purpose outputs controlled via I2C.
XTAL	I	Input terminal for 27MHz crystal oscillator or connection for external oscillator with CMOS compatible square wave clock signal
XTAL1	O	Second terminal for crystal oscillator; not connected if external clock source is used
DVSS1-3	G	Ground for Digital supply
DVDD1-3	P	Digital Supply Voltage (+3.3V )
DVDDIO	P	Digital I/O supply Voltage (+3.3V)
DVSSIO	G	Digital I/O ground
AVSS	G	Ground for Analog Supply
AVDD	P	Analog Supply Voltage (+5V)
AVSS1-6	G	Analog Input Channels ground if single ended mode is selected. These pins should be connected directly to REFOUT in Differential mode is selected.
AIN1-6	I	Video Analog Input Channels
SCLOCK	I	MPU Port Serial Interface Clock Input.
SDATA	I/O	MPU Port Serial Data Input/Output.
ALSB	I	TTL Address Input, it selects the MPU address; MPU address = 88H ALSB = 0, disables I <sup>2</sup> C filter MPU address = 8AH ALSB = 1, enables I <sup>2</sup> C filter
RD	I	Asynchronous FIFO Read Enable signal. A logical high on this pin enables a read from the output of the FIFO.
DV	O	DV or Data Valid output signal. In SCAPI/CAPI mode: DV performs a two functions depending on whether SCAPI or CAPI is selected. It toggles high when the FIFO has reached the AFF margin set by the user, and remains high until the FIFO is empty. The alternative mode is where it can be used to control FIFO reads for bursting information out of the FIFO. In API mode DV indicates valid data in the FIFO, which includes both pixel information and control codes. The polarity of this pin is controlled via PDV.
<u>OE</u>	I	Output Enable controls pixel port outputs. A logical high will tri-state P19-P0.
<u>HREF/HRESET</u>	O	Dual function pin, HREF or Horizontal Reference output signal (enabled when Line Locked Interface is selected , OM_SEL[1:0] = 0,0); this signal is used to indicate data on the YUV output. The positive slope indicates the beginning of a new active line, HREF is always 720 Y samples long. <u>HRESET</u> or Horizontal Reset Output (enabled when SCAPI or CAPI is selected, OM_SEL[1:0] = 0,1 or 1,0) is a signal the indicates the beginning of a new line of video. In SCAPI/CAPI this signal is one clock cycle wide and is output relative to CLKIN. It immediately follows the last active pixel of a line. The polarity is controlled via PHVR.

# PRELIMINARY TECHNICAL DATA

## ADV7183

### PIN DESCRIPTION

Mnemonic	Input/Output	Function
<u>VREF/VRESET</u>	O	VREF or Vertical Reference output signal, indicates start of next field). <u>VRESET</u> or Vertical Reset Output is a signal that indicates the beginning of a new field. In SCAPI/CAPI mode this signal is one clock wide and active low relative to CLKIN. It immediately follows <u>HRESET</u> pixel, and it indicates that the next active pixel is the first active pixel of the next field.
LLCREF	O	Clock reference output; this is a clock qualifier distributed by the internal CGC for a data rate of LLC2. The polarity of LLCREF is controlled by PLLCREF bit.
LLC1/PCLK	O	Dual function pin, Line Locked Clock system output clock (27MHz $\pm$ 5%) or a FIFO output clock ranging from 20-35MHZ.
LLC2	O	Line locked clock system output clock/2 (13.5MHz).
ELPF	I	This pin is used for the External Loop Filter that is required for the LLC PLL.
<u>RESET</u>	I/O	System Reset, can be configured as an Input or Output signal (the RES bit can be used to control this pin).
<u>PWRDN</u>	I	Power Down enable, a logical low will place part in a power down status.
REFOUT	O	Internal Voltage Reference Output.
CML	O	Common Mode Level for ADC.
AEF	O	Almost Empty Flag is a FIFO control signal. It indicates when the FIFO has reached the almost empty margin set by the user (use FFM[4:0]). The ploarity of this signal is controled by PFF bit.
HFF/QCLK/GL	I/O	Multi function pin, Half Full Flag (OM_SEL[1:0] = 1,0) is a FIFO control signal which indicates when the FIFO is half full. The QCLK (OM_SEL[1:0] = 0,1) pin function is a qualified pixel output clock when using FIFO SCAPI mode. The GL (OM_SEL[1:0] = 0,0) function (Genlock output) is a signal that contains a serial stream of data which contains information for locking the subcarrier frequency. The ploarity of HFF signal is controled by PFF bit.
AFF	O	Almost Full Flag is a FIFO control signal. It indicates when the FIFO has reached the almost full margin set by the user (use FFM[4:0]). The ploarity of this signal is controled by PFF bit.
CLKIN	I	CLKIN is an asynchronous FIFO clock. This asynchronous clock is used to output data onto the P19-P0 bus and other control signals. The LLC1 clock can be tied to this pin and the frequency programmed by CLKVAL[17:0].
FIELD	O	ODD/EVEN field output signal. A active state indicates that an even field is being digitized. The polarity of this signal is controlled by PF bit.
HS/HACTIVE	O	Dual function pin, HS or Horizontal Sync (OM_SEL[1:0] = 0,0) is a programmable horizontal sync output signal. The rising and falling edges can be controlled by HSB[9:0] and HSE[9:0] in steps of 2 LLC1. The ploarity of HS signal is controled by PHS bit. HACTIVE (OM_SEL[1:0] = 1,0 or 0,1) is an output signal that is active during the active/viewable period of a video line. The active portion of a video line is programmable on the ADV7183.
The		polarity of HACTIVE is controlled by PHS bit.
VS/VACTIVE	O	Dual function pin, VS or Vertical Sync (OM_SEL[1:0] = 0,0) is an output signal that indicates a vertical sync with respect to the YUV pixel data. The active period of this signal is six lines of video long. The ploarity of VS signal is controled by PVS bit. VACTIVE (OM_SEL[1:0] = 1,0 or 0,1) is an output signal that is active during the active/viewable period of a video field. The polarity of VACTIVE is controlled by PVS bit.

# PRELIMINARY TECHNICAL DATA

# ADV7183

## PIN DESCRIPTION

Mnemonic	Input/Output	Function
ISO	I	ISO (Input Switch Over) a low to high transition on this input indicates to the decoder core that the input video source has been changed externally and configures the decoder to reacquire the new timing information of the new source. This is useful in applications where external video muxs are used. This input gives the advantage of faster locking to the external muxed video sources. A low to high transition triggers this input.
CAPY1-2	I	ADC Capacitor network.
CAPC1-2	I	ADC Capacitor network.

# PRELIMINARY TECHNICAL DATA

## ADV7183

### ABSOLUTE MAXIMUM RATINGS \*

V <sub>AA</sub> to GND.....	7V
Voltage on any Digital Input Pin.....	GND-0.5V to V <sub>AA</sub> +0.5V
Storage Temperature (T <sub>S</sub> ).....	-65°C to +150°C
Junction Temperature(T <sub>J</sub> ).....	+150°C
Lead Temperature (Soldering, 10 secs).....	+260°C
Analog Outputs to GND <sup>1</sup> .....	GND -0.5 to V <sub>AA</sub>

### ORDERING GUIDE

Model Option	Temperature Range	Package
ADV7183KST	0°C to 70°C	80 LQFP

### NOTES

\*Stresses above those listed under “Absolute Maximum Ratings” may cause permanent damage to the device. This is a stress rating only and functional operation of the device at these or any other conditions above those listed in the operational sections of this specification is not implied. Exposure to absolute maximum rating conditions for extended periods may affect device reliability.

<sup>1</sup>Analog Output Short Circuit to any Power Supply or Common can be of an indefinite duration.

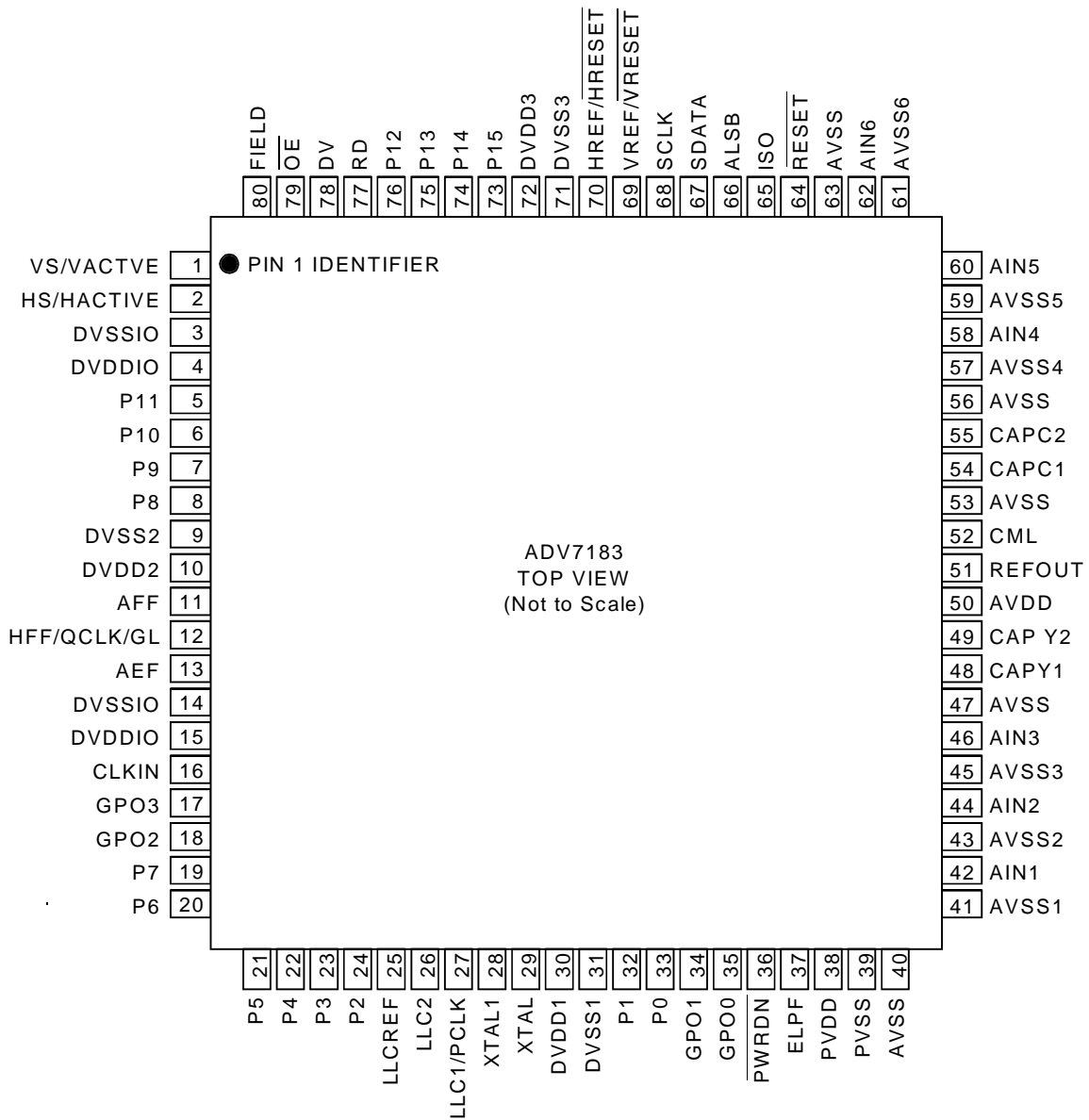

**ADV7183 PIN FUNCTIONALITY**

SPECIFICATIONS<sup>1</sup>

( $V_{AA} = +5V \pm 5\%$ ,  $V_{DD} = +3.3V \pm 5\%$ ,  $V_{DDIO} = +3.3V \pm 5\%$   
 All specifications  $T_{MIN}$  to  $T_{MAX}$ <sup>2</sup> unless otherwise noted)

Parameter	Min	Typ	Max	Units	Test Conditions
<b>STATIC PERFORMANCE</b>					
Resolution (each ADC)			9	Bits	Guaranteed Monotonic
Accuracy (each ADC)					
Integral Nonlinearity		$\pm 0.5$		LSB	
Differential Nonlinearity		$\pm 0.5$		LSB	
<b>DIGITAL INPUTS</b>					
Input High Voltage, $V_{INH}$	2			V	$V_{IN} = 0.4V$ or $2.4V$
Input Low Voltage, $V_{INL}$			0.8	V	
Input Current, $I_{IN}$	-10		10	$\mu A$	
Input Capacitance, $C_{IN}$			10	pF	
<b>DIGITAL OUTPUTS</b>					
Output High Voltage, $V_{OH}$	2.4			V	$I_{SOURCE} = 3.2$ mA $I_{SINK} = 0.4$ mA
Output Low Voltage, $V_{OL}$			0.4	V	
High Impedance Leakage Current			10	$\mu A$	
Output Capacitance			30	pF	
<b>VOLTAGE REFERENCE</b>					
Reference Range, $V_{REFOUT}$		2.1		V	$I_{VREFOUT} = 0\mu A$
<b>POWER REQUIREMENTS</b>					
Digital Power Supply, $V_{DD}$	3.15	3.3	3.45	V	CVBS, CCIR-656, $V_{DD} = 3.3V$ CBVS, PAL Sq Pixel, $V_{DD} = 3.3V$ CVBS, CCIR-656, $V_{AA} = 5.25V$ CVBS, PAL Sq Pixel, $V_{AA} = 5.25V$ Sleep mode until powered up
Analog Power Supply, $V_{AA}$	4.75	5.0	5.25	V	
Digital Supply Current, $I_{DD}^3$		150		mA	
Digital Supply Current, $I_{DD}^3$		154		mA	
Analog Supply Current, $I_{AA}^4$		150		mA	
Analog Supply Current, $I_{AA}^4$		150		mA	
Power-up Time		1		field	

## NOTE

<sup>1</sup> The max/min specifications are guaranteed over this range. The max/min values are typical over  $V_{AA} = 4.75V$  to  $5.25V$  and  $V_{DD}/V_{DDIO} = 3.15V$  to  $3.45V$  range

<sup>2</sup> Temperature Range  $T_{MIN}$  to  $T_{MAX}$ :  $0^{\circ}C$  to  $70^{\circ}C$ .

<sup>3</sup>  $I_{DD}$  is total current taken by DVDD & DVDIO supply pins.

<sup>4</sup>  $I_{AA}$  is total analog current taken by AVDD supply pins.

Specifications subject to change without notice.

PRELIMINARY TECHNICAL DATA

# ADV7183

## VIDEO PERFORMANCE SPECIFICATIONS<sup>1</sup> ( $V_{AA} = +5V \pm 5\%$ , $V_{DD} = +3.3 \pm 5\%$ , $V_{DDIO} = +5V/3.3 \pm 5\%$ All specifications $T_{MIN}$ to $T_{MAX}$ <sup>2</sup> unless otherwise noted)

Parameter	Min	Typ	Max	Units	Test Conditions
<b>NON-LINEAR SPECIFICATIONS</b>					
Differential Phase		1		deg	CVBS, Comb/No Comb
Differential Gain		1		%	CVBS, Comb/No Comb
Luma Non-Linearity		1		%	
Chroma Non-Linear Gain		1		%	
<b>NOISE SPECIFICATIONS</b>					
SNR (Pedestal)		60		dB	CVBS
SNR (Ramp)		57		dB	CVBS
Analog Front End Channel Crosstalk		63		dB	S-Video/ YUV, single ended
Analog Front End Channel Crosstalk		63		dB	S-Video/ YUV, differential ended
<b>LOCK TIME AND JITTER SPECIFICATIONS</b>					
Horizontal Lock Time		50		lines	TV / VCR mode
Horizontal Recovery Time		50		lines	
Horizontal Lock Range		±5		%	
Line Length Variation Over Field		±1		%	VCR mode/ Surveillance mode
Line Length Variation Over Field		±1		%	TV mode
HLock Lost Declared	10			HSync	TV mode, No. of missing HSyncs
HLock Lost Declared		20		HSync	VCR/Surveillance mode, No. of missing HSyncs
Vertical Lock Time		2		VSync	First Lock into video signal
VLock Lost Declared		1		VSync	All modes, No. of missing VSynCs
F <sub>SC</sub> Subcarrier Lock Range		±400		Hz	NTSC/PAL
Color Lock Time		50		lines	HLock to Color Lock Time
LLC Clock Jitter (Short Time Jitter)		1		ns	RMS Clock Jitter
LLC Clock Jitter (Frame Jitter)		37		ns	RMS Clock Jitter
<b>CHROMA SPECIFIC SPECIFICATIONS</b>					
Hue Accuracy		1		deg	
Color Saturation Accuracy		1		%	
Color Gain Control Range		-6	18	dB	S-Video, YUV, Overall CGC Range(analog and digital)
Analog Color Gain Range		-6	6	dB	S-Video, YUV
Digital Color Gain Range		0	12	dB	CVBS, S-Video, YUV
<b>LUMA SPECIFIC SPECIFICATIONS</b>					
Luma Brightness Accuracy		1.0		%	Video Input Range = 1.0Vp-p
Luma Contrast Accuracy		1.0		%	Video Input Range = 1.0Vp-p

NOTE

<sup>1</sup> The max/min specifications are guaranteed over this range. The max/min values are typical over  $V_{AA} = 4.75V$  to  $5.25V$  and  $V_{DD}/V_{DDIO} = 3.15V$  to  $3.45V$  range

<sup>2</sup> Temperature Range  $T_{MIN}$  to  $T_{MAX}$ :  $0^{\circ}C$  to  $70^{\circ}C$ .  
Specifications subject to change without notice.



TIMING SPECIFICATIONS<sup>1</sup>

( $V_{AA} = +5V \pm 5\%$ ,  $V_{DD} = /3.3V \pm 5\%$ ,  $V_{DDIO} = +3.3V \pm 5\%$   
 All specifications  $T_{MIN}$  to  $T_{MAX}$ <sup>2</sup> unless otherwise noted)

Parameter	Min	Typ	Max	Units	Test Conditions
SYSTEM CLOCK AND CRYSTAL Nominal Frequency		27		MHz	
I <sup>2</sup> C PORT					
SCL Clock Frequency	0		400	kHz	
SCL min pulse width high, $t_1$	0.6			$\mu$ s	
SCL min pulse width low, $t_2$	1.3			$\mu$ s	
Hold Time (Start Condition), $t_3$	0.6			$\mu$ s	
Setup time (Start Condition), $t_4$	0.6			$\mu$ s	
Data Setup Time, $t_5$	100			ns	
SCL/SDA Rise Time, $t_6$			300	ns	
SCL/SDA Fall Time, $t_7$			300	ns	
Setup Time (Stop Condition), $t_8$		0.6		$\mu$ s	
RESET FEATURE					
Reset Pulse Input Width	tbd			$\mu$ s	
CLOCK OUTPUTS					
LLC1 Cycle Time, $t_9$		37		ns	CCIR601 mode 27MHz
LLC1 Cycle Time, $t_9$		33.9		ns	PAL Square Pixel mode 29.5MHz
LLC1 Cycle Time, $t_9$		40.8		ns	NTSC Square Pixel mode 24.5MHz
LLC1 min low period, $t_{10}$		18		ns	CCIR601 mode 27MHz
LLC1 min high period, $t_{11}$		18		ns	CCIR601 mode 27MHz
LLC1 falling to LLCREF falling, $t_{12}$		4		ns	
LLC1 falling to LLCREF rising, $t_{13}$		6		ns	
LLC1 rising to LLC2 rising, $t_{14}$		3		ns	
LLC1 rising to LLC2 falling, $t_{15}$		2		ns	
CLKIN Cycle Time, $t_{18}$		37		ns	SCAPI & CAPI modes
DATA AND CONTROL OUTPUT					
Data Output Hold Time, $t_{17}$		8		ns	LLC mode
Data Output Access Time, $t_{16}$		28		ns	LLC mode
Data Output Access Time, $t_{19}$		20		ns	SCAPI & CAPI modes
Data Output Hold Time, $t_{20}$		10		ns	SCAPI & CAPI modes
Propagation Delay to HiZ, $t_{21}$		5		ns	
Max Output Enable access Time, $t_{22}$		8		ns	
Min Output Enable access Time, $t_{23}$		5		ns	

## NOTE

<sup>1</sup> The max/min specifications are guaranteed over this range. The max/min values are typical over  $V_{AA} = 4.75V$  to  $5.25V$  and  $V_{DD}/V_{DDIO} = 3.15V$  to  $3.45V$  range

<sup>2</sup> Temperature Range  $T_{MIN}$  to  $T_{MAX}$ :  $0^{\circ}C$  to  $70^{\circ}C$ .

Specifications subject to change without notice.

# PRELIMINARY TECHNICAL DATA

## ADV7183

### ANALOG FRONT END SPECIFICATIONS<sup>1</sup> ( $V_{AA} = +5V \pm 5\%$ , $V_{DD} = +3.3 \pm 5\%$ , $V_{DD} = +5V/3.3 \pm 5\%$ , All specifications $T_{MIN}$ to $T_{MAX}$ <sup>2</sup> unless otherwise noted)

Parameter	Min	Typ	Max	Units	Test Conditions
<b>CLAMP CIRCUITRY</b>					
External Clamp Capacitor		0.1		$\mu F$	Clamp switched off
Input Impedance		500		$k\Omega$	
Voltage Clamp Level		1.4		V	Signal already clamped (fine clamping)
Clamp Source Current		+4		$\mu A$	
Clamp Sink Current		-4		$\mu A$	Signal already clamped (fine clamping)
Clamp Source Current		+0.9		mA	Aquire mode (fast clamping)
Clamp Sink Current		-0.8		mA	Aquire mode (fast clamping)

**NOTE**

<sup>1</sup> The max/min specifications are guaranteed over this range. The max/min values are typical over  $V_{AA} = 4.75V$  to  $5.25V$  and  $V_{DD}/V_{DDIO} = 3.15V$  to  $3.45V$  range

<sup>2</sup> Temperature Range  $T_{MIN}$  to  $T_{MAX}$ :  $0^{\circ}C$  to  $70^{\circ}C$ .  
Specifications subject to change without notice.

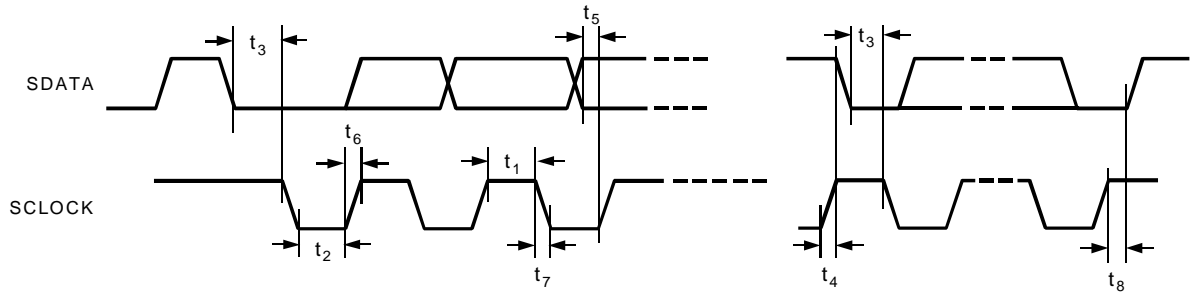

Figure 2. MPU Port Timing Diagram

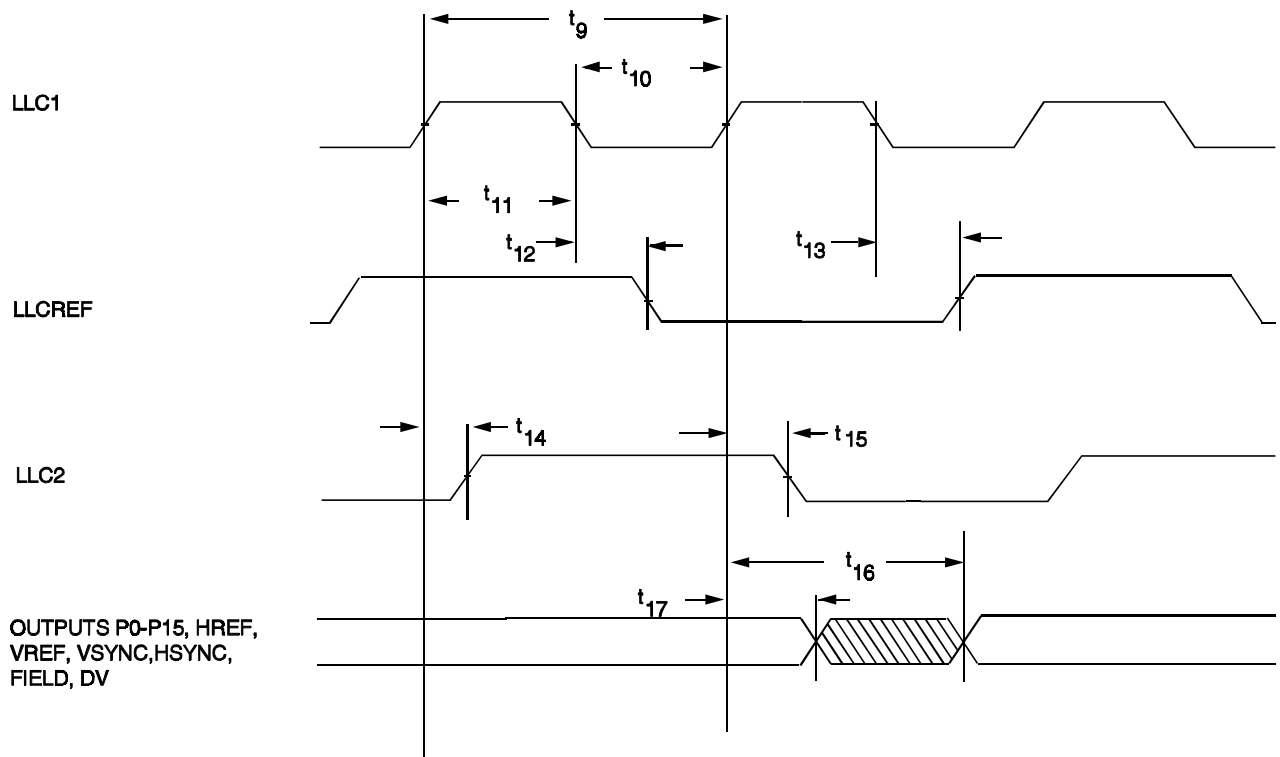

Figure 3. LLC Clock, Pixel Port & Control Outputs Timing Diagram

# ADV7183

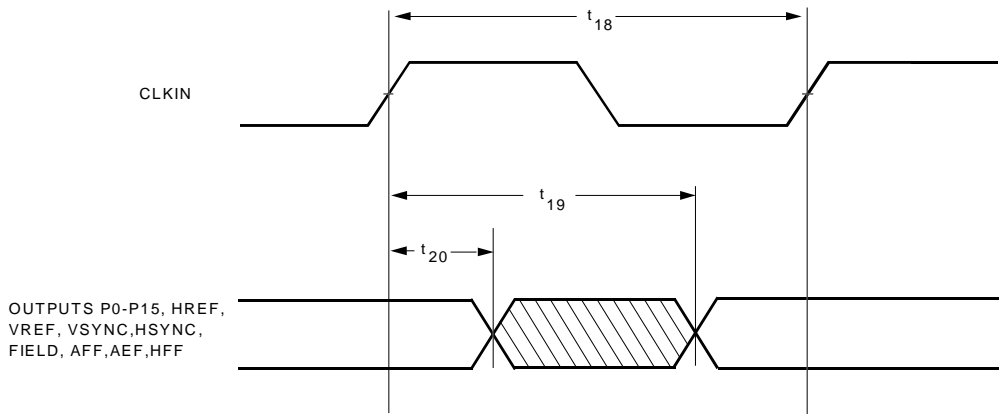

Figure 4. Pixel Port & Control Outputs in CAPI & SCAPI mode Timing Diagram

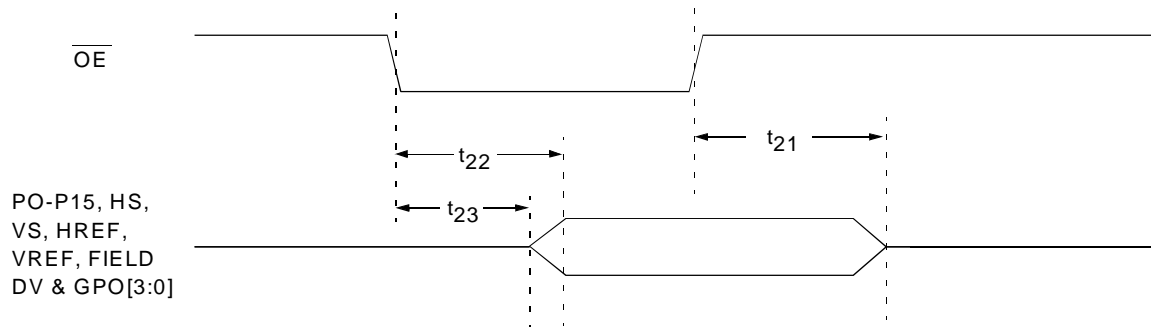

Figure 5  $\overline{OE}$  Timing Diagram

## FUNCTIONAL DESCRIPTION

### ANALOG INPUT PROCESSING

The ADV7183 has 6 analog video input channels. These 6 channels can be arranged in a variety of configurations to support up to 6 CVBS input signals, 3 S-Video inputs signals and 2 YCrCb component analog video inputs signals. The INSEL[3:0] control the input type and channel selected. The analog front-end includes 3 clamp circuits for DC restore. There are 3 Sample and Hold Amplifiers prior to the ADC which are used to enable simultaneous sampling of up to 3 channels in a YCrCb input mode. There are 2 9-bit ADC's used for sampling. The entire analog front-end is fully differential which ensures that the video is captured to the highest quality possible, this is very important in highly integrated systems like a video decoder. The block diagram below shows the analog front-end section on the ADV7183.

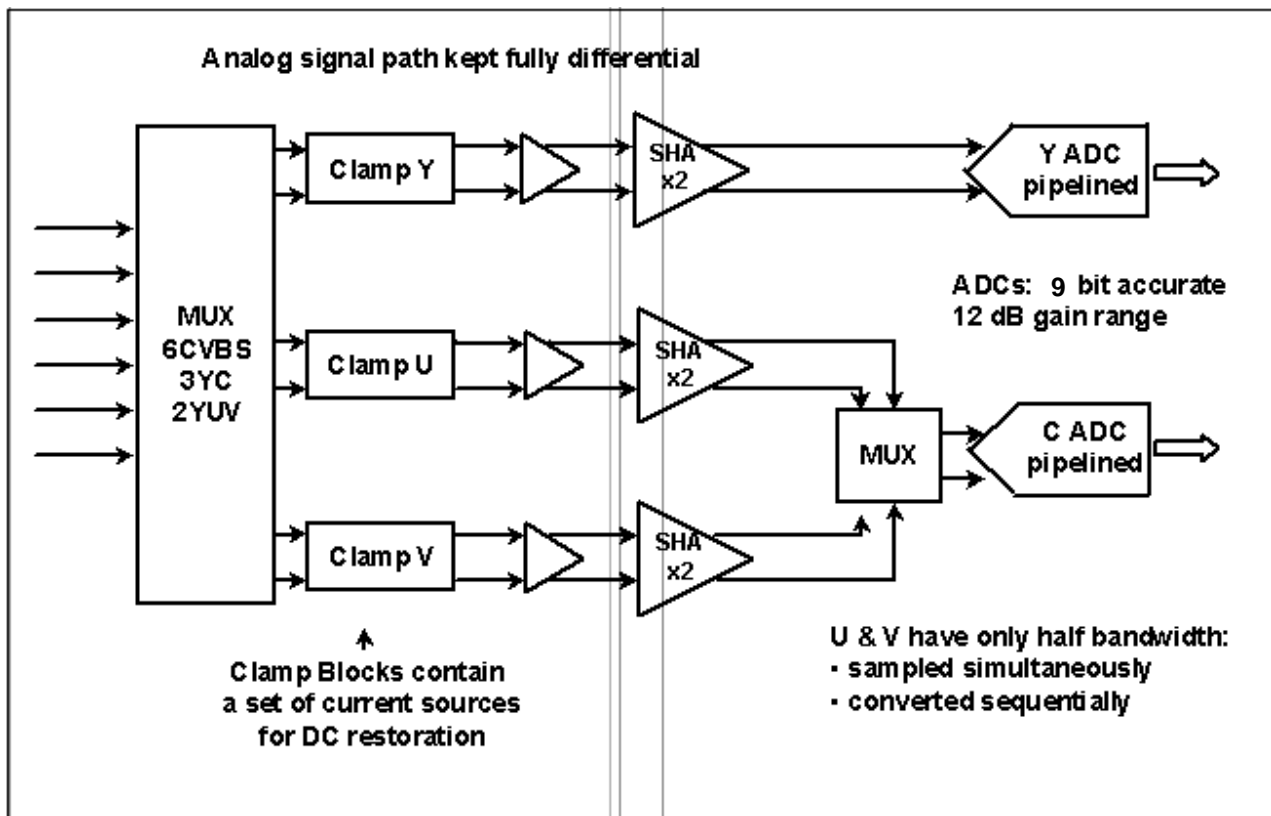

Figure XX. Analog Front-end Block Diagram

### CLAMPING

The Clamp control on the ADV7183 consists of a digitally controlled analog current and voltage clamp and a digitally controlled digital clamp circuit. The coupling capacitor on each channel is used to store and filter the clamping voltage. A digital controller controls the Clamp up and down current sources which charge the capacitor on every line. There are four current sources used in the current clamp control, 2 large current sources are used for Course Clamping and two small current sources are used for Fine Clamping. The Voltage Clamp if enabled is only used on startup or if a channel is switched, this clamp pulls the video into the mid range of the ADC, this result in faster clamping and faster lock in time for the decoder. The fourth clamp controller is fully digital and clamps the ADC output data, this results in extremely accurate clamping, it also has the added advantage of being fully digital which result in very fast clamp timing and makes the entire clamping process very robust in terms of handling large amount of Hum which can be present on real world video signals.

In S-Video mode there are 2 clamp controllers used to control the Luminance clamping and the Chrominance clamping separately. Also in YCrCb component input mode there are 2 clamp controllers used to control the Luminance clamping and the CrCb clamping separately, there is however individual current clamps on the Cr & Cb inputs.

User programmability is built into the clamp controllers which enable the Current and Digital clamp controllers to be setup to user defined conditions. Refer to Analog Clamp Control Register(14H), Digital Clamp Control Register(15H) & Digital Color Clamp offset Register(15H & 16H) for control settings.

# ADV7183

## ANALOG TO DIGITAL CONVERTERS

There are two 10-bit ADC used in the ADV7183. These ADC run off a 27MHz input clock. An integrate bandgap generates the required reference voltages for the converters. If the deocder in configured in CVBS mode the 2nd ADC can be switched off to reduce power consumption, see PSC[1:0].

## AUTOMATIC GAIN CONTROL

The AGC control block on the ADV7183 is a digitally based systems. This controller ensures that the input video signal (CVBS, S-Video or YCrCb) is scaled to its correct value such that the YCrCb digital output data matches the correct gain of the video signal. The AGC has an analog input video range of 0.5Vp-p to 2.0Vp-p which gives a -6dB to +6dB gain range, Figure xx below demonstrates this range. This AGC range will compensate for video signals that have been incorrectly terminated or have been attenuated due to cable loss etc. There are 2 main control blocks one for the Luminance channel and one for the Chrominance channel.

The Luminance Automatic Gain Control has 8 modes of operation:

- 1) Manual AGC mode where gain for luminance path is set manually using LGM[11:0].
- 2) Blank Level to Sync tip used to set luminance gain, manual MIRE[2:0] controls max the value through Luminance channel. There is no override of this mode when White Peak mode is detected.
- 3) Blank Level to Sync tip used to set luminance gain, manual MIRE[2:0] controls max the value through Luminance channel. There is override of this mode when White Peak mode is detected. White peak mode is activated when the input video exceeds the max luminance range for long periods, this mode is designed to prevent clipping of the input video signal.
- 4) Blank Level to Sync tip used to set luminance gain, MIRE[2:0] is automatically controlled to set the max the value through luminance channel. There is no override of this mode when White Peak mode is detected.
- 5) Blank Level to Sync tip used to set luminance gain, manual MIRE[2:0] is automatically controlled to set the max the value through luminance channel. There is override of this mode when White Peak mode is detected. White peak mode is activated when the input video exceeds the max luminance range for long periods, this mode is designed to prevent clipping of the input video signal.
- 6) The Active video
- 7) The
- 8) The luminance channel gain is Frozen at it present value.

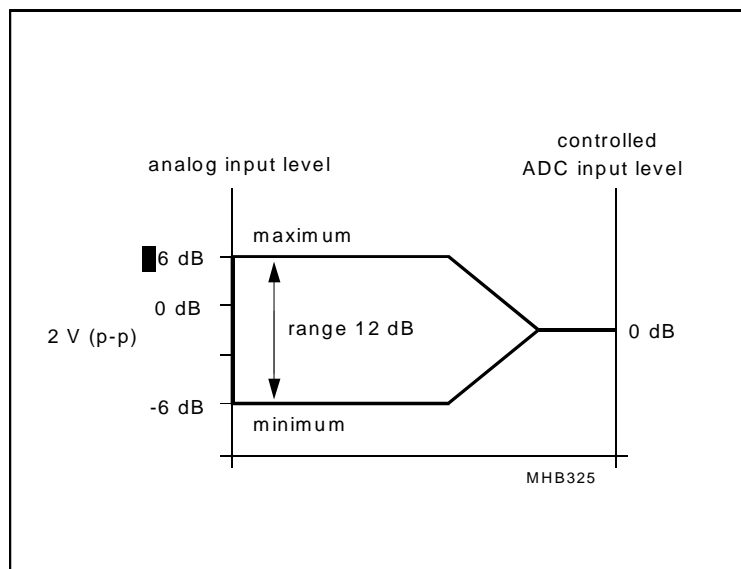

The Chrominance Automatic Gain Control has 4 modes of operation:

- 1) Manual AGC mode where gain for chrominance path is set manually using CGM[11:0].
- 2) Luminance gain used for chrominance channel.
- 3) Chrominance automatic gain based on color burst amplitude.
- 4) Chrominance gain frozen at its present setting.

Both the luminance and chrominance AGC controllers have programmable time constant which allows the AGC to operate in 4 modes, Slow, Medium, Fast & Video quality controlled.

The max IRE (MIRE [2:0]) control can be used to set the max input video range that can be decoded. Figure xx shows the selectable range.

MIRE [2 : 0]	Function	
	PAL (IRE)	NTSC (IRE)
0 0 0	133	122
0 0 1	125	115
0 1 0	120	110
0 1 1	115	105
1 0 0	110	100
1 0 1	105	100
1 1 0	100	100
1 1 1	100	100

Figure XX. MIRE control

# ADV7183

## LUMINANCE PROCESSING

Figure xx shows the luminance datapath. The 10-bit data from the Y ADC is applied to an Anti Aliasing Low Pass filter which is designed to bandlimit the input video signal such that aliasing does not occur. This filter dramatically reduces the design on an external analog anti-aliasing filter, this filter need only remove components in the input video signal above 22Mhz. The data then passes through a Shaping or Notch filter.

When in CVBS mode a Notch filter must be used to remove the unwanted chrominance data the lays around the subcarrier frequency. A wide variety of programmable Notch filters for both PAL & NTSC are available. The YSFM[4:0] control the selection of these filters, refer to figure xx to figure xx for a plots of these filters. If S-Video or Component mode is selected a Notch filter is no required, the ADV7183 offers 18 possible shaping filters(SVHS1-18) with as range of low pass filter responses from 0.5Mhz up to 5.75MHz, YSFM[4:0] control the selection of these filters please refer to figure xx to figure xx for filter plots.

The next stage in the luminance processing path is a Peaking filter, this filter offers a sharpness function on the Luminance path. The degree of sharpness can be selected using YPM[2:0]. If no sharpness is required this filter can be by-passed.

The luminance data is then passed through a resampler to correct for line length variations in the input video. This resampler is designed to always output 720 pixels per line for standard PAL or NTSC. The resampler used on the ADV7183 is of very high quality as it uses 128 phases to resample the video, giving 1/128 pixel resolution. The resampler is controlled by a sync detection block which calculates line length variations on the input video. The final stage in the luminance path before it is applied to an output formatter block is a 2 line delay store which is used to compensate for delays in the Chroma data path when Chroma Comb filter is selected.

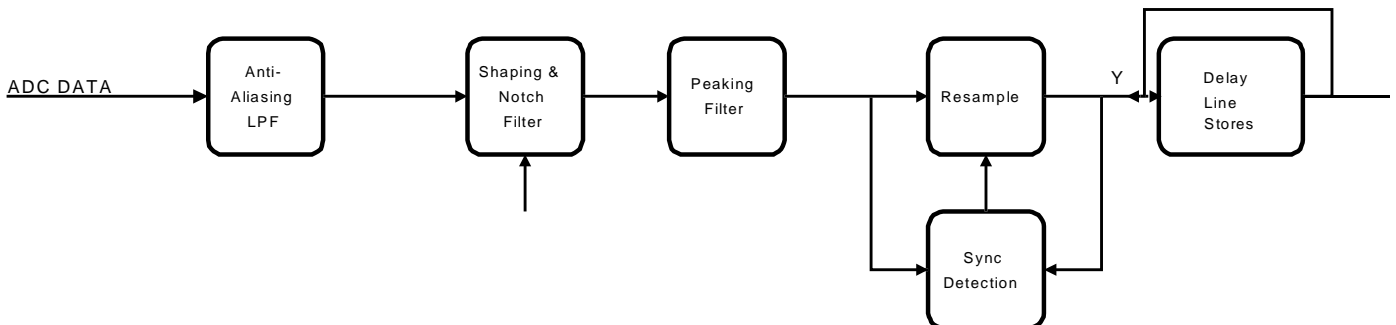

Figure XX. Luminance processing path



LUMINANCE SHAPING FILTER PLOTS

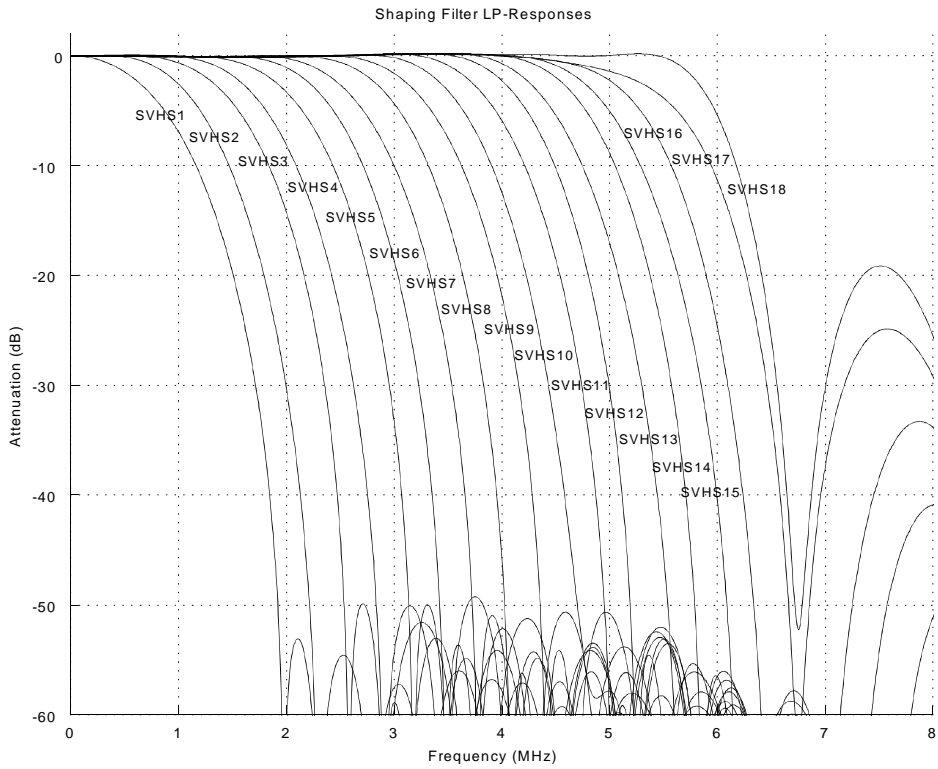

Figure xx. Luminance SVHS1-18 shaping filter responses

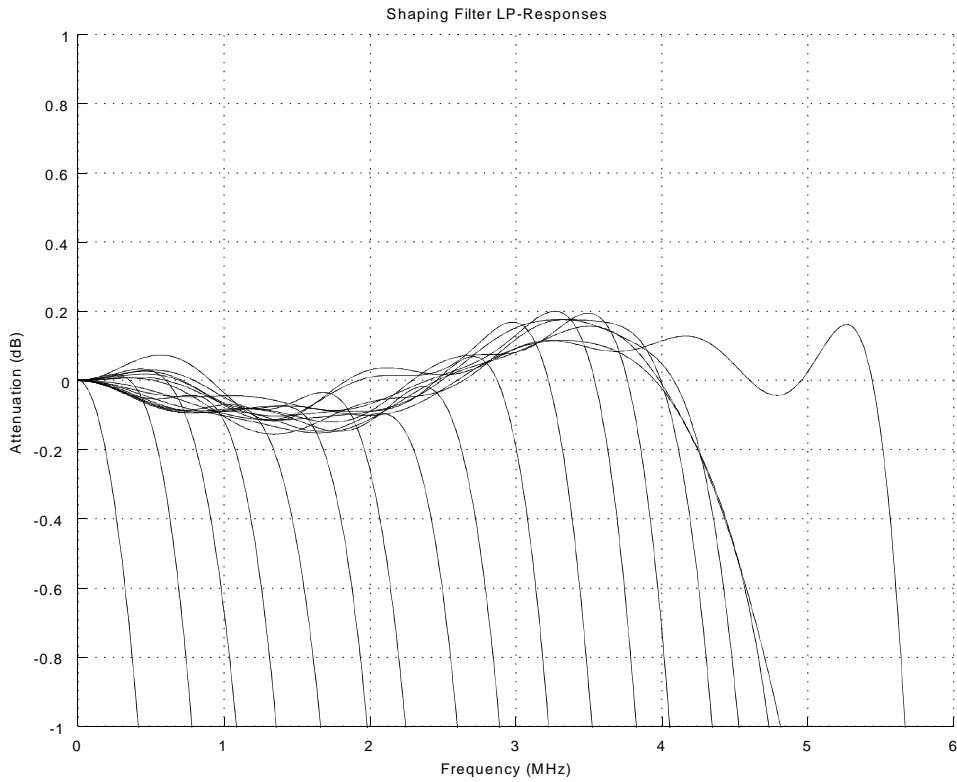

Figure xx. Luminance SVHS1-18 shaping filter responses (closeup)

# PRELIMINARY TECHNICAL DATA

## ADV7183

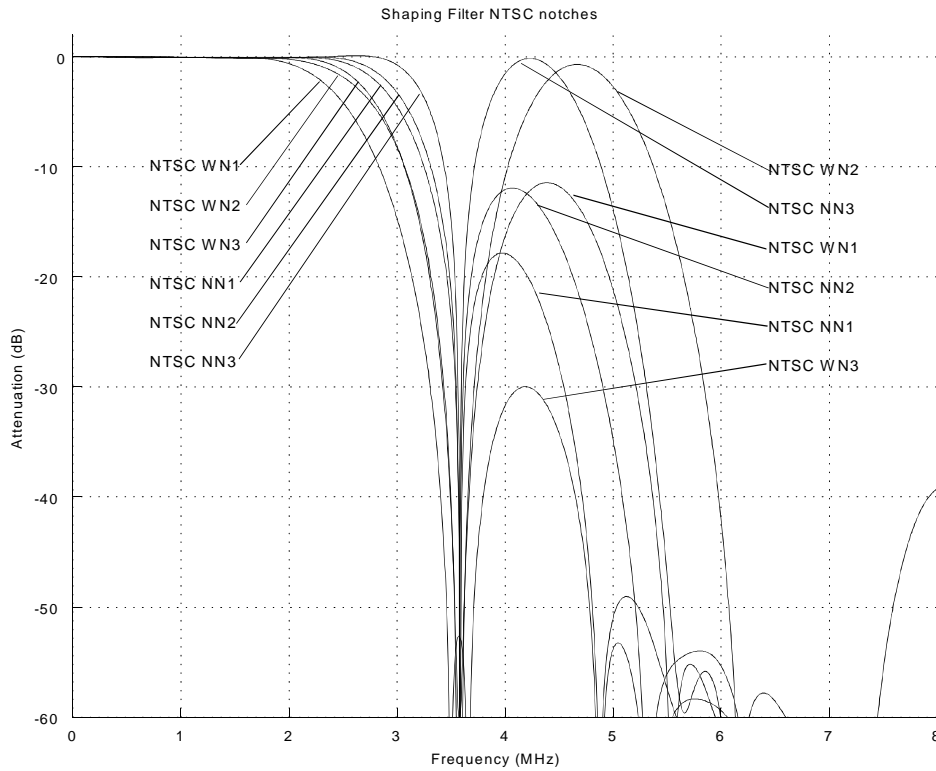

Figure xx. Luminance NTSC Narrow/Wide Notch shaping filter

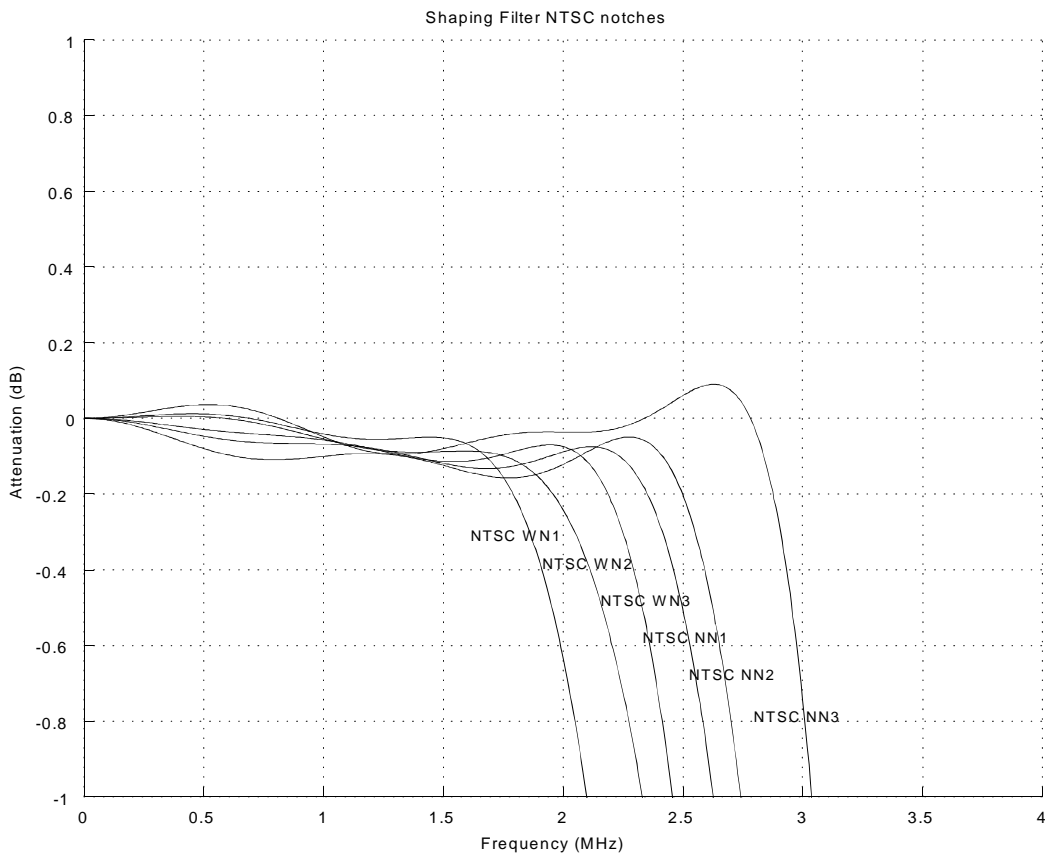

Figure xx. Luminance NTSC Narrow/Wide Notch shaping filter responses (closeup)

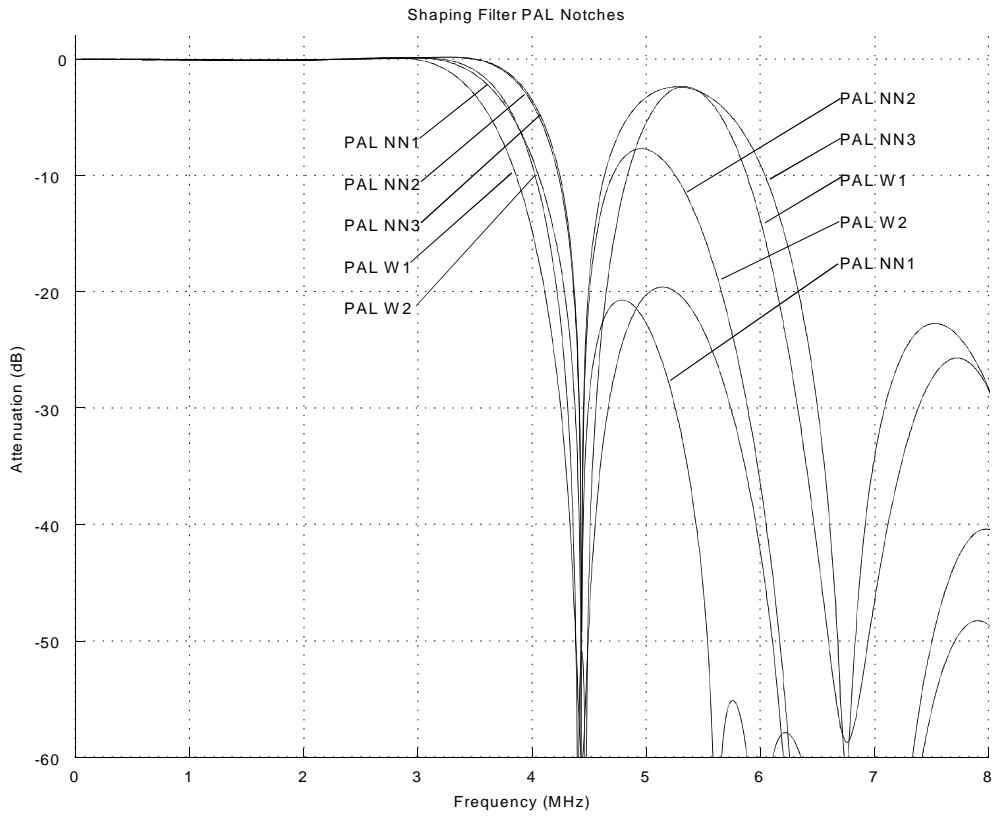

Figure xx. Luminance PAL Narrow/wide Notch shaping filter responses

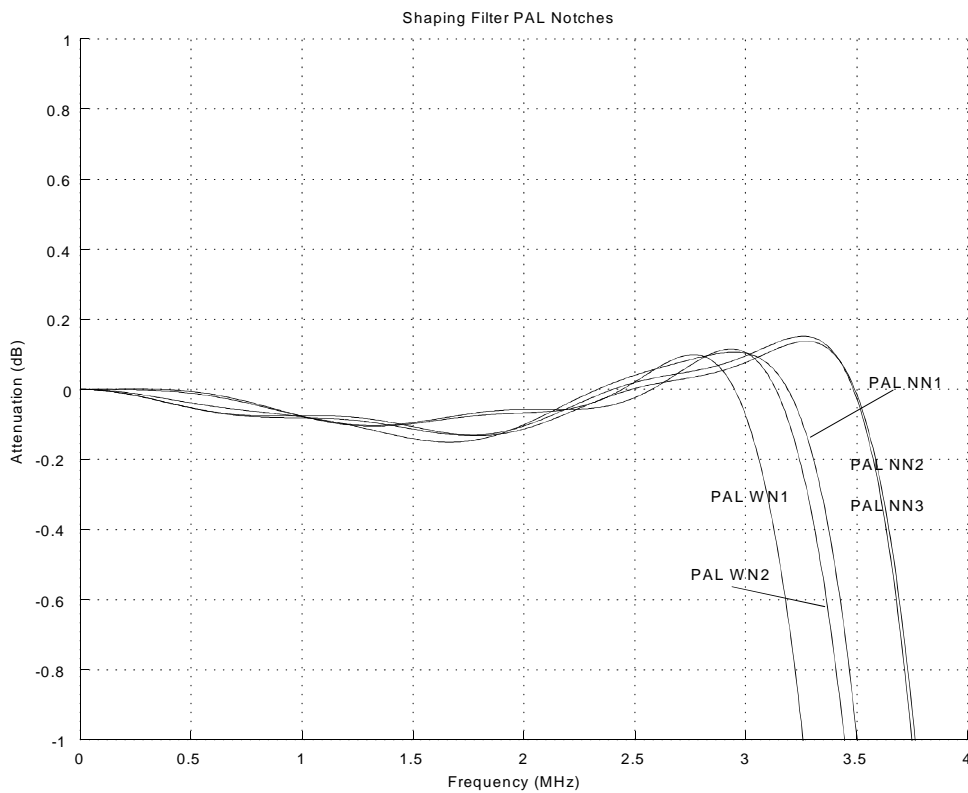

Figure xx. Luminance PAL Narrow?Wide Notch shaping filter responses (closeup)

# ADV7183

## LUMINANCE PEAKING FILTER PLOTS

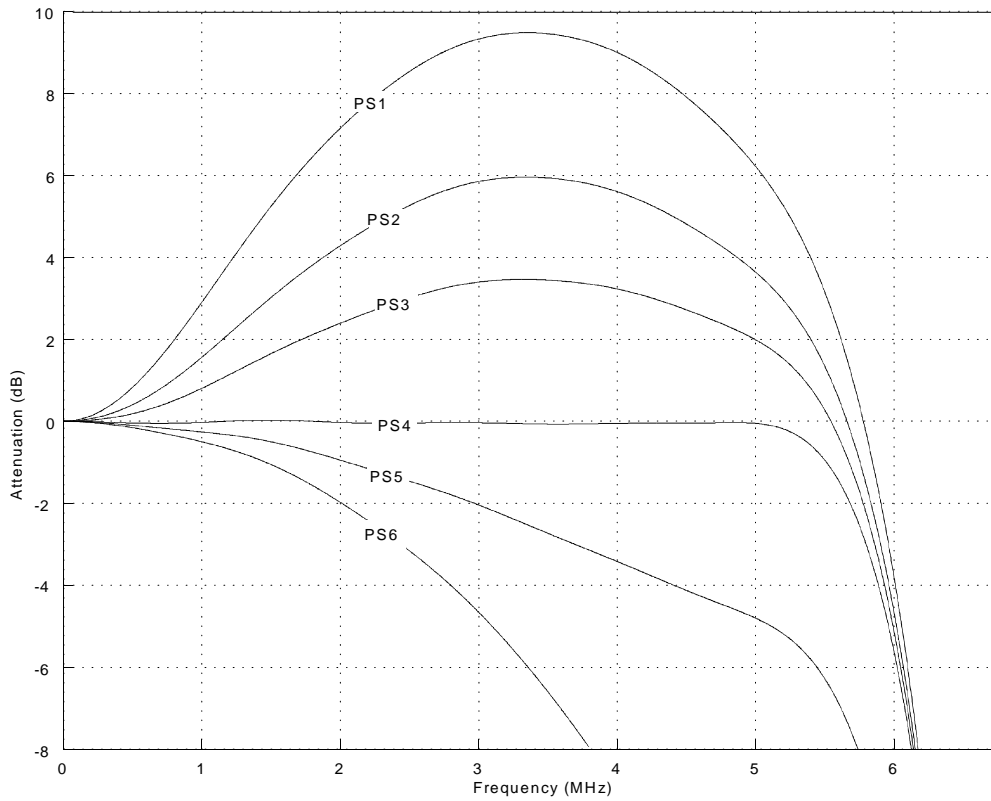

Figure xx. Luminance Peaking filter responses in S-Video (SVHS17 selected)

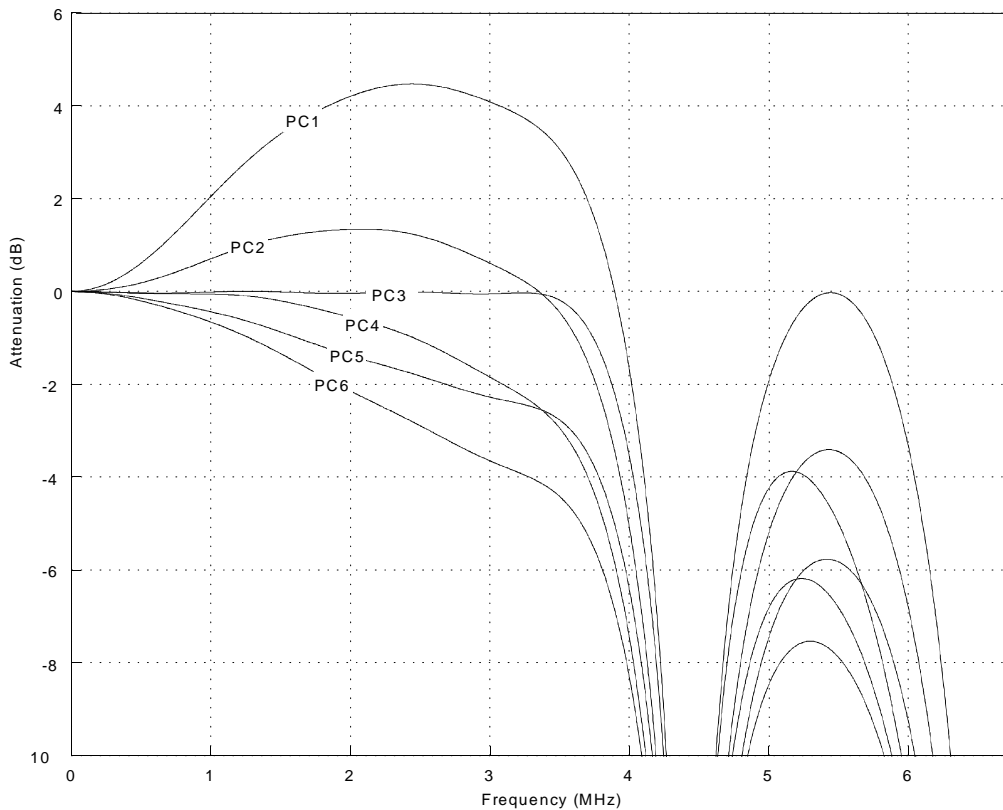

Figure xx. Luminance Peaking filter responses in CVBS (PAL NN3 selected)

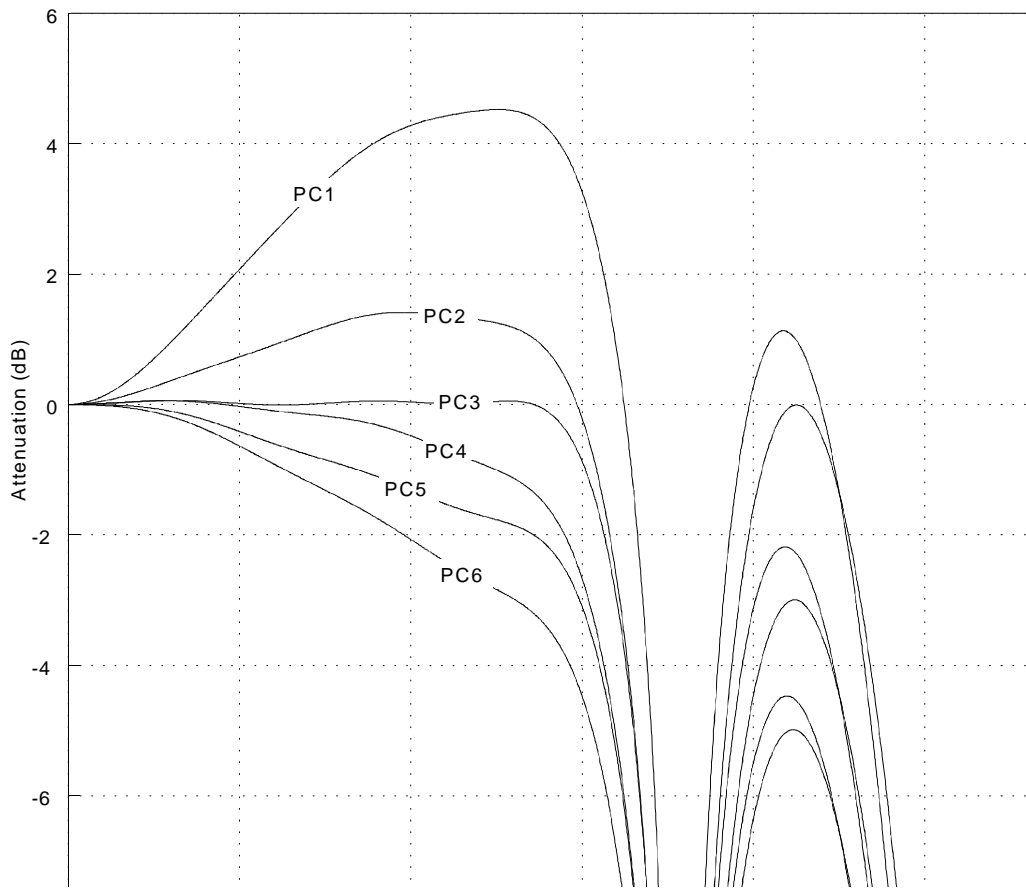

Figure xx. Luminance Peaking filter responses in CVBS (NTSC NN3 selected)

# ADV7183

## CHROMINANCE PROCESSING

Figure xx shows the chrominance datapath. The 10-bit data from the Y ADC (CVBS mode) or the C ADC (S-video) is first demodulated. The demodulation is achieved by multiplying by the locally generated quadrature subcarrier, where the sign of the cos subcarrier is inverted from line to line according to the PAL switch, and then lowpass filtering is applied to removed components at twice the subcarrier frequency. For NTSC, the phase of the locally generated subcarrier during colour burst is the same as the phase of the colour burst. For PAL, the phase of the colour burst changes from line to line, relative to the phase during active video, and the phase of the locally generated subcarrier is the average of these two values.

The chrominance data is then passed through a anti aliasing filter which is a bandpass filter to removed the unwanted luminance data. This anti aliasing filter dramatically reduces the external anti aliasing filter requirements as it has only to filter components above 25Mhz. In component mode the demodulation block is by-passed.

The next stage of processing is a Shaping filter which can be used to limit the chrominance bandwidth too between 0.5Mhz and 3Mhz, the CSFM[2:0] can be used to select these responses. It should be noted that in CVBS mode a filter or no greater than 1.5Mhz should be selected as CVBS video is typically bandlimited to below 1.5Mhz. In S-Video mode a filter of up to 2Mhz can be used. In Component mode a filter of up to 3 Mhz can be used as component video has higher bandwidth than CVBS or S-Video.

The chrominance data is then passed through a resampler to correct for line length variations in the input video. This resampler is designed to always output 720 pixels per line for standard PAL or NTSC. The resampler used on the ADV7183 is of very high quality as it uses 128 phases to resample the video, giving 1/128 pixel resolution. The resampler is controlled by a sync detection block which calculates line length variations on the input video. The final stage in the chrominance path before it is applied to an output formatter block is Chroma Comb filter.

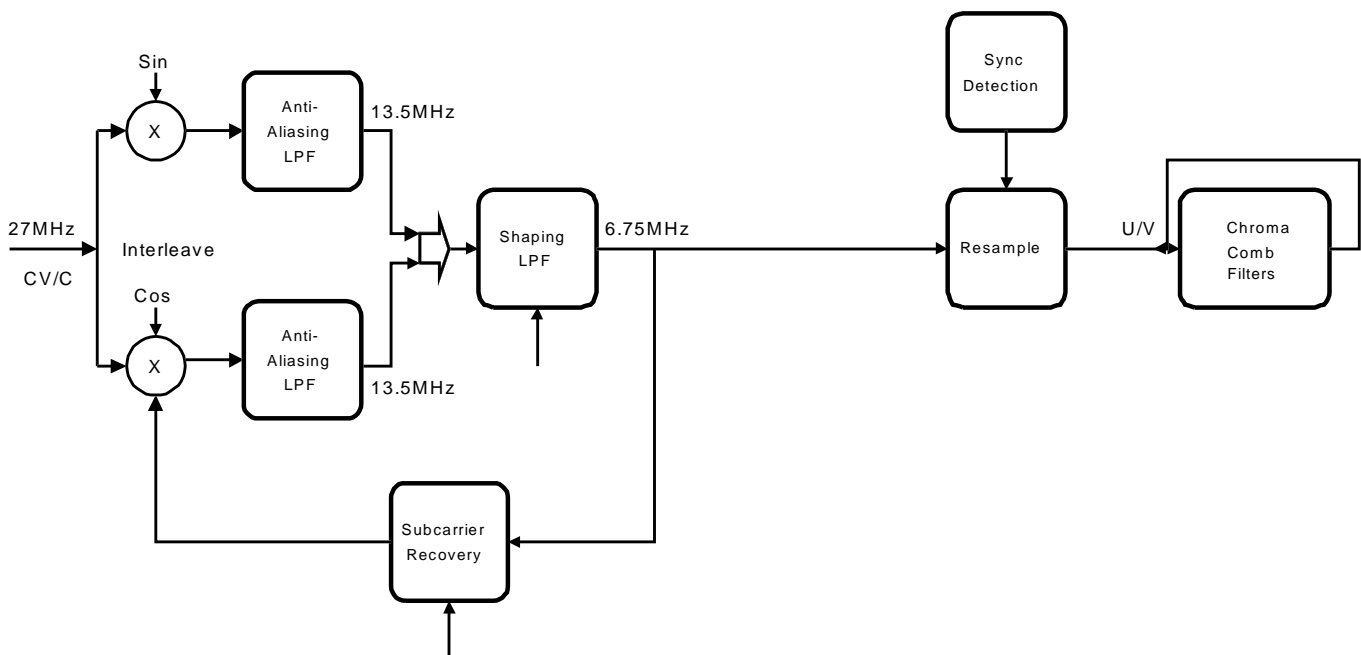

Figure XX. Chrominance processing path

CHROMINANCE SHAPING FILTER L PLOTS

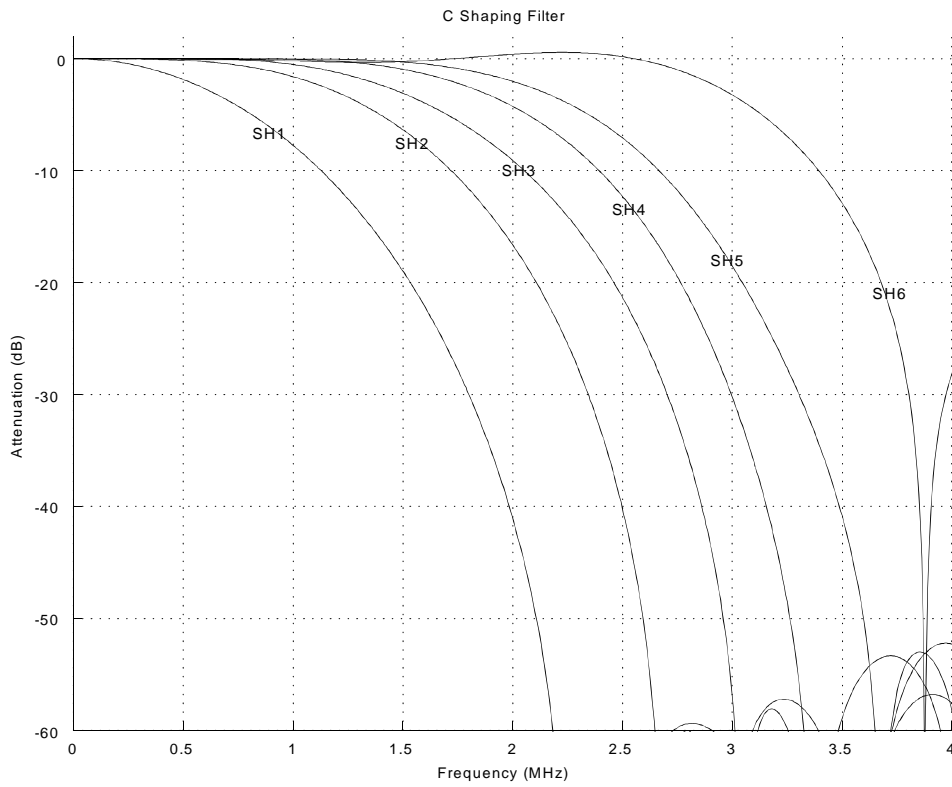

Figure xx. Chrominance shaping filter responses

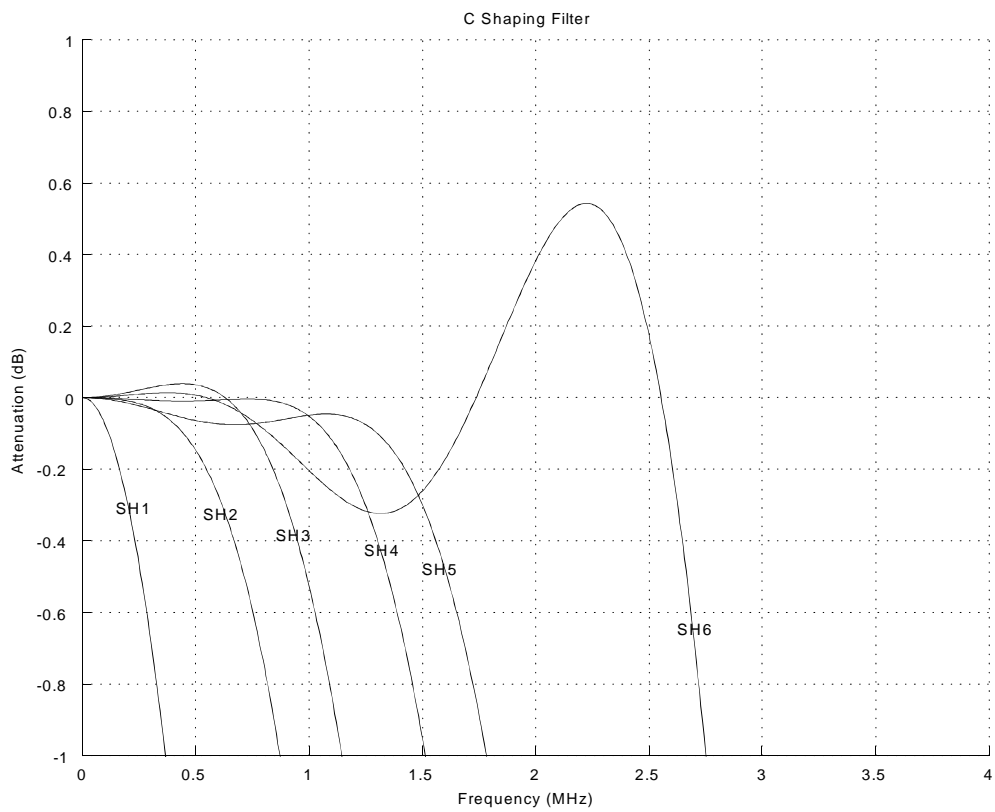
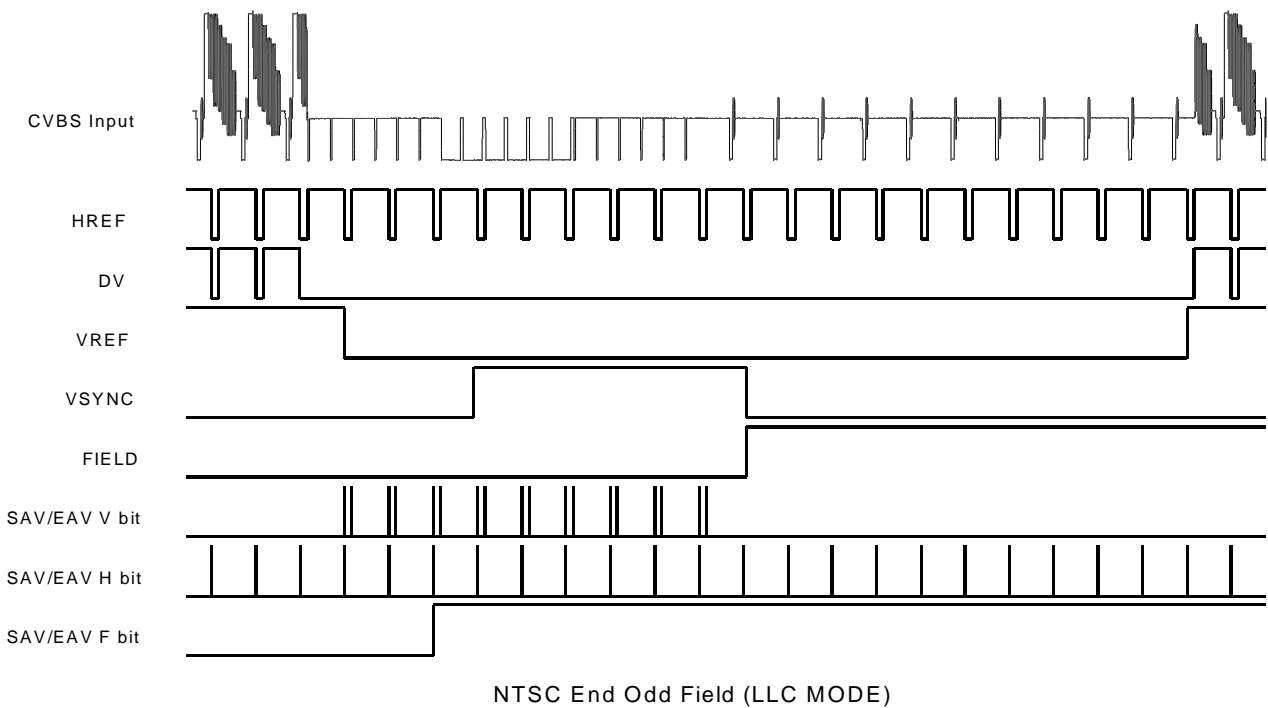
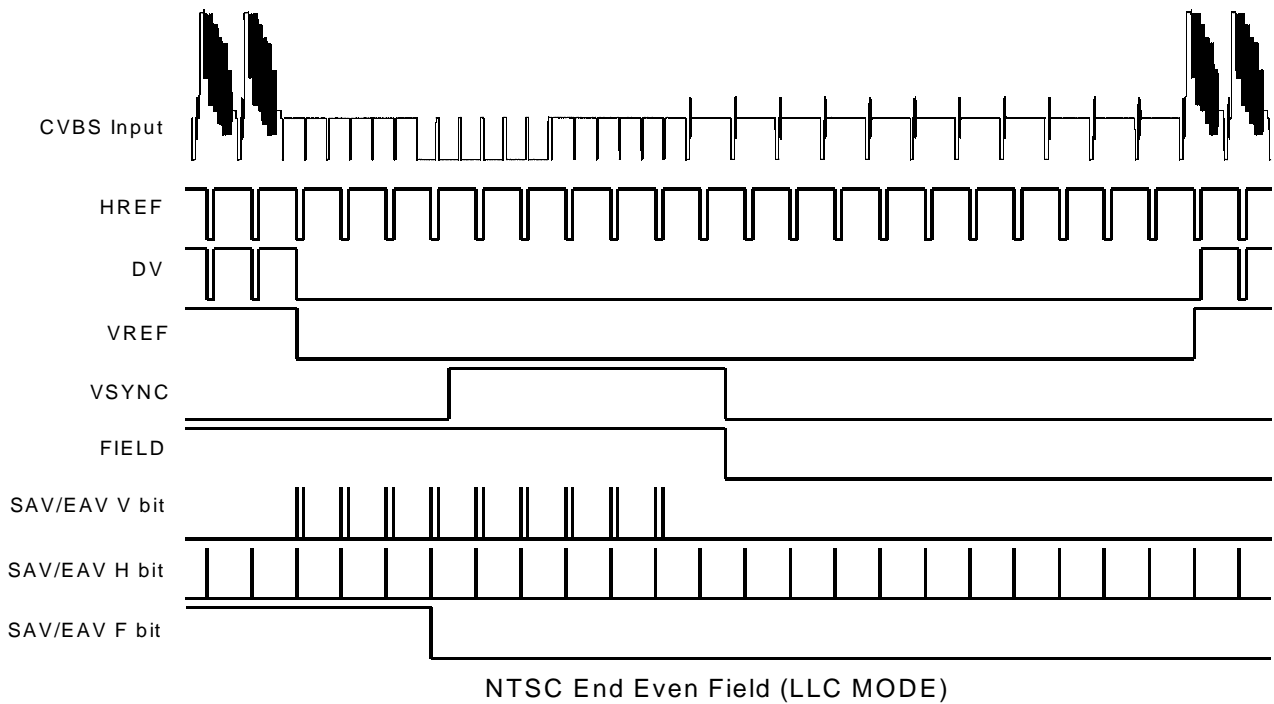

Figure xx. Chrominance shaping filter responses (closeup)

# ADV7183

## NTSC OUTPUT TIMING DIAGRAMS





PAL OUTPUT TIMING DIAGRAMS

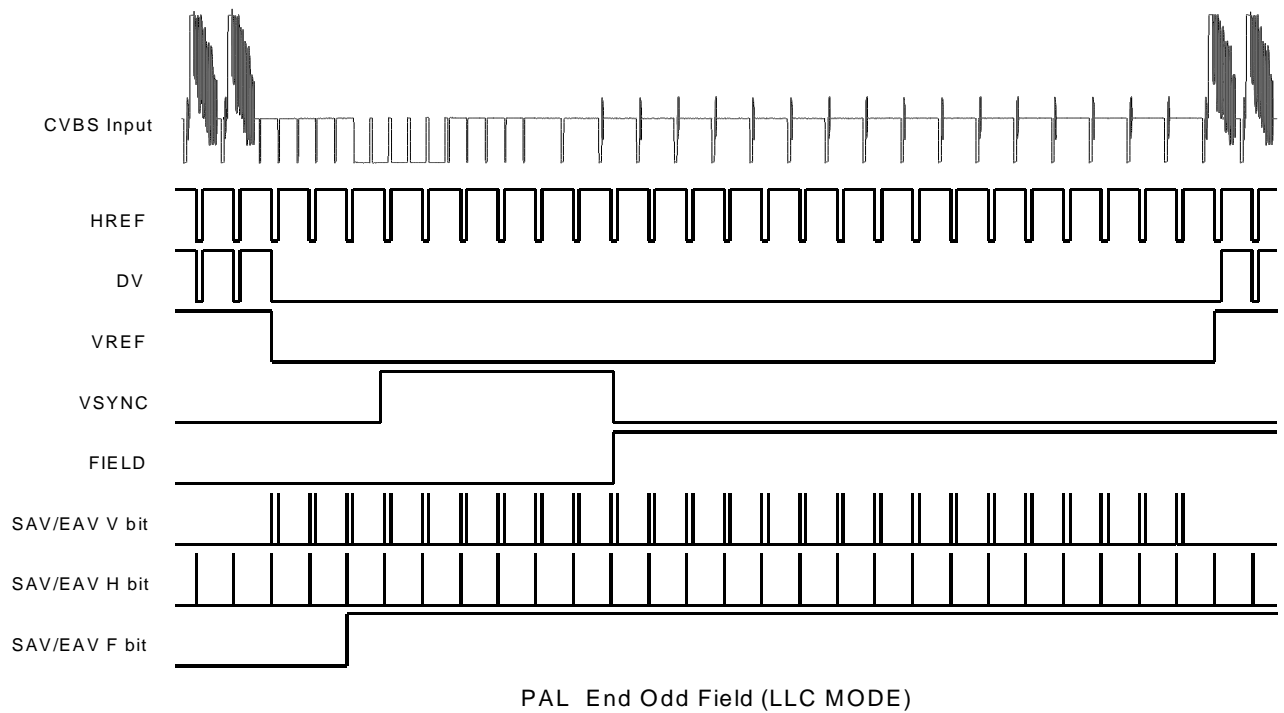
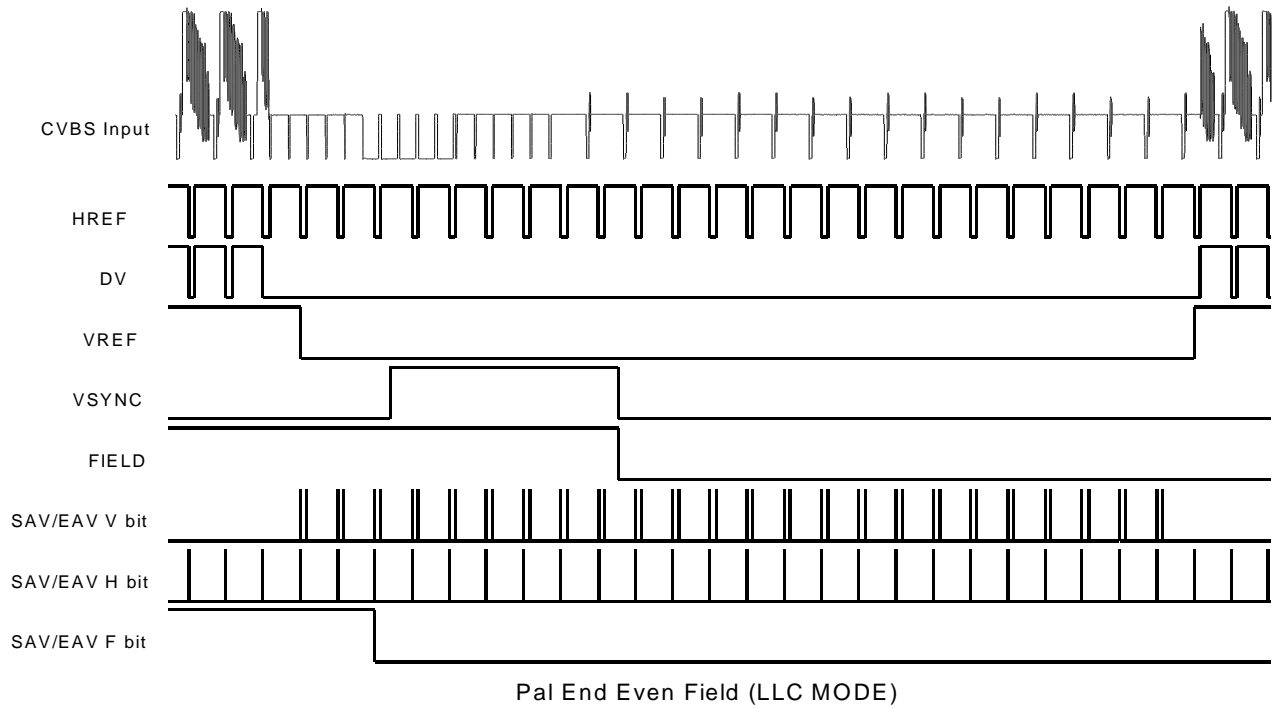

# ADV7183

## MPU PORT DESCRIPTION.

The ADV7183 support a two wire serial ( $I^2C$  Compatible) microprocessor bus driving multiple peripherals. Two inputs Serial Data (SDATA) and Serial Clock (SCLOCK) carry information between any device connected to the bus. Each slave device is recognised by a unique address. The ADV7183 has two possible slave addresses for both read and write operations. These are unique addresses for the device and are illustrated in Figure xx. The LSB sets either a read or write operation. Logic level "1" corresponds to a read operation while logic level "0" corresponds to a write operation. A1 is set by setting the ALSB pin of the ADV7183 to logic level "0" or logic level "1".

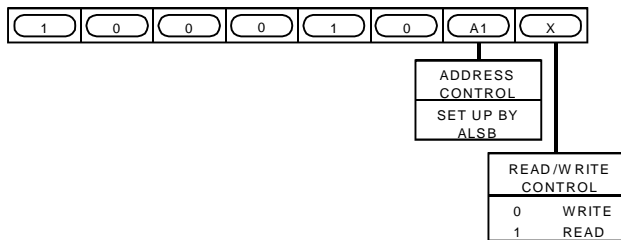

Fig xx. ADV7183 Slave Address

To control the device on the bus the following protocol must be followed. First the master initiates a data transfer by establishing a Start condition, defined by a high to low transition on SDATA whilst SCLOCK remains high. This indicates that an address/data stream will follow. All peripherals respond to the Start condition and shift the next eight bits (7-Bit address + R/W bit). The bits transferred from MSB down to LSB. The peripheral that recognises the transmitted address responds by pulling the data line low during the ninth clock pulse. This is known as an acknowledge bit. All other devices withdraw from the bus at this point and maintain an idle condition. The idle condition is where the device monitors the SDATA and SCLOCK lines waiting for the Start condition and the correct transmitted address. The R/W bit determines the direction of the data. A logic "0" on the LSB of the first byte means that the master will write information

to the peripheral. A logic "1" on the LSB of the first byte means that the master will read information from the peripheral.

The ADV7183 acts as a standard slave device on the bus. The data on the SDATA pin is 8 bits long supporting the 7-Bit addresses plus the R/W bit. The ADV7183 has 71 subaddresses to enable access to the internal registers. It therefore interprets the first byte as the device address and the second byte as the starting subaddress. The subaddresses auto increment allowing data to be written to or read from from the starting subaddress. A data transfer is always terminated by a Stop condition. The user can also access any unique subaddress register on a one by one basis without having to update all the registers.

Stop and Start conditions can be detected at any stage during the data transfer. If these conditions are asserted out of sequence with normal read and write operations, then these cause an immediate jump to the idle condition. During a given SCLOCK high period the user should only issue one Start condition, one Stop condition or a single Stop condition followed by a single Start condition. If an invalid subaddress is issued by the user, the ADV7183 will not issue an acknowledge and will return to the idle condition. If in auto-increment mode, the user exceeds the highest subaddress then the following action will be taken:

1. In Read Mode the highest subaddress register contents will continue to be output until the master device issues a no-acknowledge. This indicates the end of a read. A no-acknowledge condition is where the SDATA line is not pulled low on the ninth pulse.
2. In Write Mode, the data for the invalid byte will be not be loaded into any subaddress register, a no-acknowledge will be issued by the ADV7183 and the part will return to the idle condition.

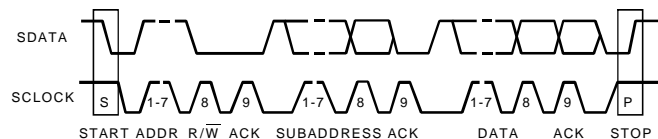

Figure yy. Bus Data Transfer

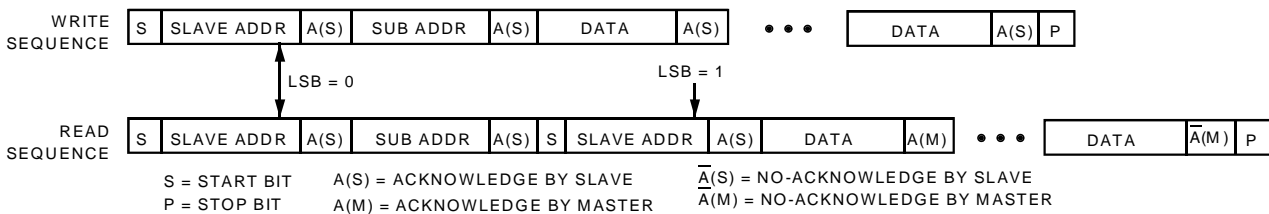

Figure 35 Illustrates an example of data transfer for a read sequence and the Start and Stop conditions.

Figure 36. Write and Read Sequences

**REGISTER ACCESSES**

The MPU can write to or read from all of the registers of the ADV7183 except the Subaddress Register which is a write only register. The Subaddress Register determines which register the next read or write operation accesses. All communications with the part through the bus start with an access to the Subaddress Register. Then a read/write operation is performed from/to the target address which then increments to the next address until a Stop command on the bus is performed.

**REGISTER PROGRAMMING**

The following section describes each register in terms of its

configuration.

**Subaddress Register (SR7-SR0)**

The Communications Register is an eight bit write-only register. After the part has been accessed over the bus and a read/write operation is selected, the subaddress is set up. The Subaddress Register determines to/from which register the operation takes place.

Figure 37 shows the various operations under the control of the Subaddress Register. Zero should always be written to SR7-SR6.

**Register Select (SR5-SR0):**

These bits are set up to point to the required starting address.

Register Name	addr (Hex)		Register Name	addr (Hex)
<b>BASIC BLOCK</b>			<b>ADVANCED BLOCK</b>	
Input Control	00		Reserved	1D
Video Selection	01		Reserved	1E
Video Enhancement Control	02		Reserved	1F
Output Control	03		Reserved	20
Extended Output Control	04		Reserved	21
General Purpose Output	05		Reserved	22
Reserved	06		Color Subcarrier Control 1	23
FIFO Control	07		Color Subcarrier Control 2	24
Contrast Control	08		Color Subcarrier Control 3	25
Saturation Control	09		Color Subcarrier Control 4	26
Brightness Control	0A		Pixel Delay Control	27
Hue Control	0B		Manual Clock Control 1	28
Default Value Y	0C		Manual Clock Control 2	29
Default Value C	0D		Manual Clock Control 3	2A
Temporal Decimation	0E		Auto Clock Control	2B
Power Management	0F		AGC Mode Control	2C
Status Register	10		Chroma Gain Control 1	2D
Info Register	11		Chroma Gain Control 2	2E
			Luma Gain Control 1	2F
<b>ADVANCED BLOCK</b>			Luma Gain Control 2	30
Reserved	12		Manual Gain Shadow Control 1	31
Analog Control (internal)	13		Manual Gain Shadow Control 2	32
Analog Clamp Control	14		Misc Gain Control	33
Digital Clamp Control 1	15		Hsync Position Control 1	34
Digital Clamp Control 2	16		Hsync Position Control 2	35
Shaping Filter Control	17		Hsync Position Control 3	36
Reserved	18		Polarity Control	37
Comb Filter Control	19		Reserved	44
Reserved	1A		Reserved	45
Reserved	1B		Reserved	F1
Reserved	1C		Reserved	F2

Figure 37. Subaddress Register

Table 1.0 Basic Registers

Register Name	addr (Hex)	D7	D6	D5	D4	D3	D2	D1	D0
Input Control	00	VID SEL.3	VID SEL.2	VID SEL.1	VID SEL.0	INSEL.3	INSEL.2	INSEL.1	INSEL.0
Video Selection	01	ASE	-	BETACAM	4FSC	DIFFIN	SQPE	VID QUAL.1	VID QUAL.0
Video Enhancement Control	02	-	-	-	COR.1	COR.0	YPM.2	YPM.1	YPM.0
Output Control	03	VBIEN	TOD	OF SEL.3	OF SEL.2	OF SEL.1	OF SEL.0	OM SEL.1	OMEL.0
Extended Output Control	04	BT656.4	-	-	-	-	-	-	RANGE
General Purpose Output	05	HL_EN	BL_C_VBI	GPEH	GPEL	GP0.3	GP0.2	GP0.1	GP0.0
Reserved	06	-	-	-	-	-	-	-	-
FIFO Control	07	FFST	AFR	FR	FFM.4	FFM.3	FFM.2	FFM.1	FFM.0
Contrast Control	08	CON.7	CON.6	CON.5	CON.4	CON.3	CON.2	CON.1	CON.0
Saturation Control	09	SAT.7	SAT.6	SAT.5	SAT.4	SAT.3	SAT.2	SAT.1	SAT.0
Brightness Control	0A	BRI.7	BRI.6	BRI.5	BRI.4	BRI.3	BRI.2	BRI.1	BRI.0
Hue Control	0B	HUE.7	HUE.6	HUE.5	HUE.4	HUE.3	HUE.2	HUE.1	HUE.0
Default Value Y	0C	DEF Y.5	DEF Y.4	DEF Y.3	DEF Y.2	DEF Y.1	DEF Y.0	DEF_AUTO_EN	DEF_VAL_EN
Default Value C	0D	DEF C.7	DEF C.6	DEF C.5	DEF C.4	DEF C.3	DEF C.2	DEF C.1	DEF C.0
Temporal Decimation	0E	-	TDR.3	TDR.2	TDR.1	TDR.0	TDC.1	TDC.0	TDE
Power Management	0F	RES	TRAQ	PWRDN	PS CG	PS REF	PDBP	PSC.1	PSC.0
Status Register	10	STATUS.7	STATUS.6	STATUS.5	STATUS.4	STATUS.3	STATUS.2	STATUS.1	STATUS.0
Info Register	11	IDENT.7	IDENT.6	IDENT.5	IDENT.4	IDENT.3	IDENT.2	IDENT.1	IDENT.0

Table 2.0 Advanced Registers

Register Name	addr (Hex)	D7	D6	D5	D4	D3	D2	D1	D0
Reserved	12	-	-	-	-	-	-	-	-
Reserved	13	-	-	-	-	-	-	TIM_OE	-
Analog Clamp Control	14	-	-	VCLEN	CCLEN	FACL.1	FACL.0	FICL.1	FICL.0
Digital Clamp Control 1	15	DCCM	DCT.1	DCT.0	DCT.0	DCC0.11	DCC0.10	DCC0.9	DCC0.8
Digital Clamp Control 2	16	DCC0.7	DCC0.6	DCC0.5	DCC0.4	DCC0.3	DCC0.2	DCC0.1	DCC0.0
Shaping Filter Control	17	CSEFM.2	CSEFM.1	CSEFM.0	YSFM.4	YSFM.3	YSFM.2	YSFM.1	YSFM.0
Reserved	18	-	-	-	-	-	-	-	-
Comb Filter Control	19	-	-	-	CCMB_AD	CCM.1	CCM.0	-	-
Color Subcarrier Control 1	23	-	-	-	CSM	CSMF.27	CSMF.26	CSMF.25	CSMF.24
Color Subcarrier Control 2	24	CSMF.23	CSMF.22	CSMF.21	CSMF.20	CSMF.19	CSMF.18	CSMF.17	CSMF.16
Color Subcarrier Control 3	25	CSMF.15	CSMF.14	CSMF.13	CSMF.12	CSMF.11	CSMF.10	CSMF.9	CSMF.8
Color Subcarrier Control 4	26	CSMF.7	CSMF.6	CSMF.5	CSMF.4	CSMF.3	CSMF.2	CSMF.1	CSMF.0

Table 2.1 Advanced Registers Continued

Register Name	addr (Hex)	D7	D6	D5	D4	D3	D2	D1	D0
Pixel Delay Control	27	SWPC	-	CTA.2	CTA.1	CTA.0	-	-	-
Manual Clock Control 1	28	FIX27E	CLKMANE	-	-	-	-	CLKVAL.17	CLKVAL.16
Manual Clock Control 2	29	CLKVAL.15	CLKVAL.14	CLKVA5L.13	CLKVAL.12	CLKVAL.11	CLKVAL.10	CLKVAL.9	CLKVAL.8
Manual Clock Control 3	2A	CLKVAL.7	CLKVAL.6	CLKVA5L.13	CLKVAL.4	CLKVAL.3	CLKVAL.2	CLKVAL.1	CLKVAL.0
Auto Clock Control	2B	ACKLM.2	ACKLM.1	ACKLM.0	-	-	-	-	-
AGC Mode Control	2C	-	LAGC.2	LAGC.1	LAGC.0	-	-	CAGC.1	CAGC.0
Chroma Gain Control 1	2D	CAGT.1	CAGT.0	-	-	CMG.11	CMG.10	CMG.9	CMG.8
Chroma Gain Control 2	2E	CMG.7	CMG.6	CMG.5	CMG.4	CMG.3	CMG.2	CMG.1	CMG.0
Luma Gain Control 1	2F	LAGT.1	LAGT.0	-	-	LMG.11	LMG.10	LMG.9	LMG.8
Luma Gain Control 2	30	LMG.7	LMG.6	LMG.5	LMG.4	LMG.3	LMG.2	LMG.1	LMG.0
Manual Gain Shadow Control 1	31	SGUE	-	-	-	LMGS.11	LMGS.10	LMGS.9	LMGS.8
Manual Gain Shadow Control 2	32	LMGS.7	LMGS.6	LMGS.5	LMGS.4	LMGS.3	LMGS.2	LMGS.1	LMGS.0
Misc Gain Control	33	-	CKE	-	MIRE.2	MIRE.1	MIRE.0	AV_AL	PW_UPD
Hsync Position Control 1	34	HSB.9	HSB.8	HSE.9	HSE.8	-	-	-	-
Hsync Position Control 2	35	HSB.7	HSB.6	HSB.5	HSB.4	HSB.3	HSB.2	HSB.1	HSB.0
Hsync Position Control 3	36	HSE.7	HSE.6	HSE.5	HSE.4	HSE.3	HSE.2	HSE.1	HSE.0
Polarity Control	37	PHS	PHVR	PVS	PLLCR	PF	PDV	PFF	PCLK
Resample control	44	-	FSC_INV	-	-	-	-	-	-
Reserved	45	-	-	-	-	-	-	-	-
Reserved	F1h	-	-	-	-	-	-	-	-
Reserved	F2h	-	-	-	-	-	-	-	-

# PRELIMINARY TECHNICAL DATA

# ADV7183

## Register 00

Subad dress	Register	Bit Description	Bit7	Bit6	Bit5	Bit4	Bit3	Bit2	Bit1	Bit0	Register Setting		
00hex	Input Control	INSEL [3:0] The INSEL bits allow the user to select an input channel as well as the input format											
							0	0	0	0	CVBS in on AIN1	Composite	
							0	0	0	1	CVBS in on AIN2		
							0	0	1	0	CVBS in on AIN3		
							0	0	1	1	CVBS in on AIN4		
							0	1	0	0	CVBS in on AIN5		
							0	1	0	1	CVBS in on AIN6		
							0	1	1	0	Y on AIN1, C on AIN4	S-Video	
							0	1	1	1	Y on AIN2, C on AIN5		
							1	0	0	0	Y on AIN3, C on AIN6		
							1	0	0	1	Y on AIN1, U on AIN4, V on AIN5	YUV	
							1	0	1	0	Y on AIN2, U on AIN3, V on AIN6		
		VID_SEL [3:0] The VID_SEL bits allow the user to select the input video standard											
	0		0	0	0							Auto detect PAL (BGHID), NTSC (without pedestal)	
	0		0	0	1							Auto detect PAL (BGHID), NTSC (m) (with pedestal)	
	0		0	1	0							Auto detect PAL (N), NTSC (M) (without pedestal)	
	0		0	1	1							Auto detect PAL (N), NTSC (M) (with pedestal)	
	0		1	0	0							NTSC (M) without pedestal	
	0		1	0	1							NTSC (M) with pedestal	
	0		1	1	0							NTSC 4.43 without pedestal	
	0		1	1	1							NTSC 4.43 with pedestal	
	1		0	0	0							PAL BGHID without pedestal	
	1		0	0	1							PAL N with pedestal	
	1		0	1	0							PAL M without pedestal	
1	0	1	1							PAL M with pedestal			
1	1	0	0							PAL combination N			
1	1	0	1							PAL combination N with pedestal			

:

# PRELIMINARY TECHNICAL DATA

## ADV7183

Subaddress	Register	Bit Description	Bit7	Bit6	Bit5	Bit4	Bit3	Bit2	Bit1	Bit0	Register Setting	
01hex	Video selection	VID_QUAL [1:0] allows the user to influence the time constant of the system depending on the input video quality.										
									0	0	Broadcast quality	
										0	1	TV quality
										1	0	VCR quality
									1	1	Surveillance quality	
	SQPE Allows the use to enable/disable the square pixel operation.								0		Standard mode	
									1		Enable square pixel mode	
	DIFFIN Allows the user to select a differential input mode for every entry in the INSEL [3:0] table.								0		Single ended inputs	
									1		Differential inputs	
	FFSC Four Fsc Mode This bit allows the selection of a special NTSC mode where the data is resampled to 4Fsc sampling rate. As a result the LLC will operate at a 4 Fsc rate as well.											Only Valid for NTSC input.
									0		Standard Video operation	
									1		Select 4 Fsc mode ( for NTSC only)	
	BETACAM											
									0		Standard video input	
									1		Betacam input enable	
	RESERVED											
									0		A zero must be written to this bit	
	ASE Automatic Startup Enable When set a change in the INSEL register will automatically be detected and lead the device to enter a video reacquire mode. May be disabled for genlocked video sources.											
									1		INSEL change will not cause re-acquire	
											INSEL change will trigger re-acquire	

Subaddress	Register	Bit Description	Bit7	Bit6	Bit5	Bit4	Bit3	Bit2	Bit1	Bit0	Register Setting		
02hex	Video Enhancement Control	YPM [2:0] Y Peaking Filter Mode ,This function allows the user to boost/attenuate luma signals around the colour subcarrier frequency.											
									0	0	0	C=+4.5dB, S=+9.25dB	
										0	0	1	C=+4.5dB, S=+9.25dB
										0	1	0	C=+4.5dB, S=+5.75dB
										0	1	1	C=+1.25dB, S=+3.3dB
										1	0	0	No Change C=+0,S=+0
										1	0	1	C=-1.25dB, S=-3dB
										1	1	0	C=-1.75dB, S=-8dB
										1	1	1	C=-3.0dB, S=-8dB
	COR[1:0] Coring Selection, Controls optional coring of the Y output signal depending on its level.												
									0	0	No Coring		
									0	1	Truncate if Y<black+8		
									1	0	Truncate if Y<black+16		
									1	1	Truncate if Y<black+32		
Reserved													
								0	0	0	Set to Zero		



# PRELIMINARY TECHNICAL DATA

# ADV7183

Subaddress	Register	Bit Description	Bit7	Bit6	Bit5	Bit4	Bit3	Bit2	Bit1	Bit0	Register Setting				
03hex	Output Control	OM_SEL [1:0] Output Mode Selection. Selects the output mode as in the timing and interface type.								0	0	Philips compatible			
											0	1	Broktree API A compatible		
												1	0	Broktree API B compatible	
												1	1	Not Valid setting	
	OF_SEL [3:0] Allows the user to choose from a set of output formats.				0	0	0	0					Reserved		
				0	0	0	1						Reserved		
				0	0	1	0						16-bit@LLC 4:2:2 CCIR656		
				0	0	1	1						8-bit@LLC 4:2:2 CCIR656		
				0	1	0	0						12-bit@LLC2 4:1:1		
				0	1	0	1						10-bit@LLC 4:2:2 CCIR656	10-bit composite in	
				0	1	1	0						8-bit@LLC 4:2:2 CCIR656	10-bit composite in	
				0	1	1	1						Reserved		
				1	0	0	0						Reserved		
				1	0	0	1						8-bit@LLC 4:2:2 CCIR656	with Debug signals I	
				1	0	1	0						8-bit@LLC 4:2:2 CCIR656	with Debug signals II	
				1	0	1	1						Not Used		
				1	1	0	0						Not Used		
				1	1	0	1						Not Used		
			1	1	1	0						Not Used			
			1	1	1	1						Not Used			
	TOD Tri-State Output Drivers. This bit allows the user to tri-state the output Drivers regardless of the state of the /OE pin.														
				0									Drivers dependant on /OE pin		
				1									Drivers tri-stated.	Regardless of /OE pin	
	VBI_EN Allows VBI data (lines 1 to 21) to be passed through with only a minimum amount of filtering performed.														
				0									All lines filtered and scaled		
				1									Only active video region		

Subaddress	Register	Bit Description	Bit7	Bit6	Bit5	Bit4	Bit3	Bit2	Bit1	Bit0	Register Setting		
04hex	Extended output control	RANGE Allows the user to select the range of output values. Can be CCIR601 compliant or fill the whole accessible number range.									0	CCIR compliant	
											1	Fill whole accessible range	
											1	1	0
	Reserved Bits												
	DDOS [2:0] D Data Output selection. If the 100 pin package is used the 12 additional pins can output additional data.												
				0	0	0							No additional data
	BT656-4 Allows the user to select an output mode that is compatible with BT656-4 or BT656-3.												
				0									BT656-3 compatible
			1									BT656-4 compatible	

# PRELIMINARY TECHNICAL DATA

## ADV7183

Subaddress	Register	Bit Description	Bit7	Bit6	Bit5	Bit4	Bit3	Bit2	Bit1	Bit0	Register Setting	
05hex	General purpose Output	GPO [3:0] These general purpose outputs pins may be programmed by the user but are only available in selected output modes OF_SEL[3:0] and when the output drivers are enabled using GPEL ,GPEH and HL_Enable bits.									Pixel Data Valid off	
							0	0	0	0	User Programmable	
	GPEL General Purpose enable low This bit enables the output drivers for the general purpose outputs bits 0 and 1.										HD Test pattern off	
				0							GPO[1:0] tri-stated	
			1								GPO[1:0] enabled	
	GPEH General Purpose enable low This bit enables the output drivers for the general purpose outputs bits 3 and 2.											
				0							GPO[3:2] tri-stated	
			1								GPO[3:2] enabled	
	BL_C_VBI Blank Chroma during VBI											
			0								Decode and output colour during VBI	
			1								Blank Cr and Cb data during VBI	
	HL_EN Hlock Enable This bit causes the General Purpose output [0] pin to output Hlock instead of GPO [0]. Only available in certain output modes.										Disabled	General Purpose output (lwr bits) must be enabled GPEL
		0									GPO[0] pin function	
		1									GPO[0] shows Hlock status	

Subaddress	Register	Bit Description	Bit7	Bit6	Bit5	Bit4	Bit3	Bit2	Bit1	Bit0	Register Setting	
07h	Fifo Control	FFM [4:0] Fifo flag margin The FFM register allows the user to program the location at which the FIFO flag's AEF and AFF.										
						0	0	1	0	0	User programmable	
	FR Fifo reset Setting this bit will cause the FIFO to reset.											
			0								Normal operation	bit is auto cleared
			1								FIFO reset	
	AFR Automatic Fifo reset Setting this bit will cause the FIFO to automatically reset at the end of each field of video											
			0								No auto reset	
			1								Auto reset	
	FFST Fifo Flag Self Time Set weather the Fifo flags AEF,AFF and HFF are output synchronous to the external CLKIN of the 27Mhz internal clock.											
		0									Synchronous to CLKIN	
1										Synchronous to 27Mhz		
08h	Contrast register	CON[7:0] Contrast Adjust This is the user control for contrast adjustment	1	0	0	0	0	0	0	0		

# PRELIMINARY TECHNICAL DATA

# ADV7183

Subaddress	Register	Bit Description	Bit7	Bit6	Bit5	Bit4	Bit3	Bit2	Bit1	Bit0	Register Setting	
09h	Saturation register	SAT[7:0] Saturation Adjust This allows the user to adjust the saturation of colour output	1	0	0	0	0	0	0	0		
0Ah	Brightness register	BRI[7:0] This register controls the brightness of the video signal.	0	0	0	0	0	0	0	0		
0Bh	Hue Register	HUE[7:0] This register contains the value for the colour hue adjustment.	0	0	0	0	0	0	0	0	Range -90 with h00=0	The resolution is 1bit=.7
0Ch	Default Value Y	DEF_VAL_EN Default Value Enable								0	Use programmed value	Y, Cr and Cb values
										1	Use default value	
	DEF_VAL_AUTO_EN Default Value Auto Enable In the case of lost lock enables/disables default values.								0	Use programmed value	When lock is lost	
									1	Use default value		
0Dh	Default Value C	DEF_C[7:0] Default Value C . Cr and Cb default values are defined in this register.	0	0	0	1	0	0			Cr[7:0]={DEF_C[7:4],0,0,0,0} Cb[7:0]={DEF_C[3:0],0,0,0,0}	Cb[7:0]={DEF_C[3:0],0,0,0,0}
			1	0	0	0	1	0	0	0		

# PRELIMINARY TECHNICAL DATA

## ADV7183

Subaddress	Register	Bit Description	Bit7	Bit6	Bit5	Bit4	Bit3	Bit2	Bit1	Bit0	Register Setting		
0Eh	Temporal Decimation	TDE Temporal Decimation Enable bit allows the user to enable/disable the temporal function.									0	Disabled	Configured using TDC[1:0] and TDR[3:0]
												1	
	TDC[1:0] Temporal Decimation Control allows the user to select the suppression of selected fields of video.								0	0		Suppress frames, start with even field.	
									0	1		Suppress frames, start with odd field.	
									1	0		Suppress even fields only.	
									1	1		Suppress odd fields only.	
	TDR[3:0] Temporal Decimation Rate specifies how many fields/frames as to be skipped before a valid one is output												AS specified in the TDC[1:0] register
			0	0	0	0						Skip no Field/Frame	
			0	0	0	1						Skip 1 Field/Frame	
			0	0	1	0						Skip 2 Fields/Frames	
			0	0	1	1						Skip 3 Fields/Frames	
			0	1	0	0						Skip 4 Fields/Frames	
			0	1	0	1						Skip 5 Fields/Frames	
			0	1	1	0						Skip 6 Fields/Frames	
			0	1	1	1						Skip 7 Fields/Frames	
			1	0	0	0						Skip 8 Fields/Frames	
			1	0	0	1						Skip 9 Fields/Frames	
			1	0	1	0						Skip 10 Fields/Frames	
			1	0	1	1						Skip 11 Fields/Frames	
		1	1	0	0						Skip 12 Fields/Frames		
		1	1	0	1						Skip 13 Fields/Frames		
	1	1	1	0						Skip 14 Fields/Frames			
	1	1	1	1						Skip 15 Fields/Frames			
Reserved													
										0	Set to Zero		

# PRELIMINARY TECHNICAL DATA

## ADV7183

Subaddress	Register	Bit Description	Bit7	Bit6	Bit5	Bit4	Bit3	Bit2	Bit1	Bit0	Register Setting		
0Fh	Power Management	PSC[1:0] Power Save Control allows the a set of different power save modes to be selected .											
									0	0	Full Operation		
											0	1	CVBS input only
											1	0	Digital only
									1	1	Power Save Mode		
		PDBP Power Down Bit Priority There are two ways to shut down the digital core, the Power Down Bit which has higher priority											
									0			Pwr. Dwn. Controller by Pin	
											1		Pwr. Dwn. Controller by Bit
	PS_REF Power Save Reference allows the user to enable/disable the internal analog reference.												
									0			Reference Functional	
											1		Reference in Pwr. Save mode
	PS_CG Power Save For the LLC Clock Generator												
											0		Clock Generator functional
											1	CG in Power Save Mode	
		PWRDN Power Down Disables the input pads and powers down the 27Mhz clock											
												0	System functional
													1
	TRAQ Timing ReAquire will cause the part to reaquire the video signal and is the software version of the ISO pin.												
												0	Normal Operation
													1
	Reserved												
										0	Reserved Bit set to Zero		
10h	Status Register Read only	Status[7:0] Provides information about the internal status of the decoder.											
			x	x	x	x	x	x	x	x	x		
11h	Info Register Read Only	IDENT[7:0] Provides identification on the revision of the part.										0=v85a , 3=v85b , 4=v85b3	
			x	x	x	x	x	x	x	x	x		

PRELIMINARY TECHNICAL DATA

ADV7183

Subaddress	Register	Bit Description	Bit7	Bit6	Bit5	Bit4	Bit3	Bit2	Bit1	Bit0	Register Setting		
13h	Analog Control Internal	TIM_OE Timing Signals Output Enables the user to force the output drivers for H-SYNC,V-SYNV and Field into an active state regardless of the OE pin and TOD bit.											
									0		Dependant on OE and TOD		
										1		HS,VS,F forced active	
		Reserved											
			0	1	0	0	0	1		1	Set at Default Value		
14h	Analog Clamp Control	FICL[1:0] Fine Clamp Length controls the number of clock cycles for which the slow current is on.											
									0	0	I on for 16 clock cycles		
										0	1	I on for 32 clock cycles	
										1	0	I on for 64 clock cycles	
									1	1	I on for 128 clock cycles		
		FACL[1:0] Fast Clamp Length controls the number of clock cycles for which the fast current is on.						0	0			I on for 16 clock cycles	
								0	1			I on for 32 clock cycles	
								1	0			I on for 64 clock cycles	
								1	1			I on for 128 clock cycles	
		CCLLEN Current Clamp Enable allows the user to switch off the I sources in the analog front end											
								0					I sources switched off
								1					I sources enabled
		VCLLEN Voltage Clamp Enable bit allows the user to disable the voltage clamp circuitry											
								0					Voltage Clamp disabled
								1					Voltage Clamp enabled
		Reserved											
			0	0							Reserved set to Zero		

# PRELIMINARY TECHNICAL DATA

# ADV7183

Subaddress	Register	Bit Description	Bit7	Bit6	Bit5	Bit4	Bit3	Bit2	Bit1	Bit0	Comment	Note		
15h	Digital Clamp Control 1	DCCO[11:8] Digital Colour Clamp Offset holds upper 4-bits of the digital offset value which gets added to the raw data from the ADC before entering the core.										Only applicable if DCCM is set to manual offset mode		
						x	x	x	x					
		DCFE Digital Clamp Freeze Enable allows the user to freeze the digital clamp loop at any point in time												
					0								Digital clamp operational	
					1								Digital clamp frozen	
		DCT [1:0] Digital Clamp Timing determines the time constant of the digital clamping circuitry												
				0	0								Slow (TC: 1 sec)	
				0	1								Medium (TC: 0.5 sec)	
				1	0								Fast (TC: 0.1 sec)	
				1	1								Dependent on VID_QUAL	
				DCCM[7:0] Digital Colour Clamp Mode sets the mode of operation for the digital clamp circuitry										Offset correction via DCCO for C only
					0								Automatic digital clamp	
					1								Manual Offset correction	
16h	Digital Clamp Control 2	DCCO[7:0] Digital Colour Clamp Offset holds the lower 8-bits of the digital offset value which gets added to the raw data from the ADC before entering the core.										Only applicable if DCCM is set to manual offset mode		
			x	x	x	x	x	x	x	x				

# PRELIMINARY TECHNICAL DATA

## ADV7183

Subaddress	Register	Bit Description	Bit7	Bit6	Bit5	Bit4	Bit3	Bit2	Bit1	Bit0	Comment	Note		
17h	Shaping Filter Control	YSFM[4:0] Y Shaping Filter Mode allows the user to select a wide range of low pass and notch filters.												
						0	0	0	0	0	0	Auto Wide notch		
						0	0	0	0	0	1	Auto Narrow notch		
						0	0	0	0	1	0	SVHS 1		
						~	~	~	~	~	~	~	~	
						1	0	0	0	1	0	SVHS 17		
						1	0	0	0	1	1	PAL NN1		
						1	0	1	0	0	0	PAL NN2		
						1	0	1	0	1	0	PAL NN3		
						1	0	1	1	1	0	PAL WN 1		
						1	0	1	1	1	1	PAL WN 2		
						1	1	0	0	0	0	NTSC NN1		
						1	1	0	0	0	1	NTSC NN2		
						1	1	0	1	0	0	NTSC NN3		
						1	1	0	1	1	0	NTSC WN1		
						1	1	1	0	0	0	NTSC WN2		
						1	1	1	0	1	1	NTSC WN3		
				1	1	1	1	1	0	Not Used				
				1	1	1	1	1	1	SVHS 18				
		CSFM[2:0] C Shaping Filter Mode allows the selection from a range of low pass chrominance filters.											Auto = filter selected based on scaling factor.	
				0	0	0								Auto selection 1.5Mhz
				0	0	1								Auto selection 2.17Mhz
				0	1	0								SH1
			~	~	~							~		
			1	1	0							SH5		
		1	1	1							SH6			



# PRELIMINARY TECHNICAL DATA

# ADV7183

Subaddress	Register	Bit Description	Bit7	Bit6	Bit5	Bit4	Bit3	Bit2	Bit1	Bit0	Comment	Note		
19h	Comb Filter Control	Reserved												
										0	0	Set to Zero		
		CCM[1:0] Chroma Comb Mode selects a primary mode for the filter												
								0	0			No Comb		
								0	1			1H		
								1	0			2H		
								1	1			Not Valid, do not use		
		CCMB_AD Chroma Comb Adaptive												
							0						Chroma Comb non-adaptive	
							1						Chroma Comb adaptive	
	Reserved													
			0	0	0						Set to Zero			
23h	Colour Subcarrier Control 1	CSMF[27:24] Colour Subcarrier Manual Frequency Holds the value used to enable the user support odd subcarrier frequencies												
							x	x	x	x				
		CSM Colour Subcarrier Manual												
					0								Manual Fsc. Disabeled	
					1								User defined Fsc.	Defined in CSFM[27:0]
	Reserved													
			1	1	1						Set to One			
24h	Colour Subcarrier Control 2	CSMF[23:16] Colour Subcarrier Manual Frequency Holds the value used to enable the user support odd subcarrier frequencies												
			x	x	x	x	x	x	x	x				
25h	Colour Subcarrier Control 3	CSMF[15:8] Colour Subcarrier Manual Frequency Holds the value used to enable the user support odd subcarrier frequencies												
			x	x	x	x	x	x	x	x				
26h	Colour Subcarrier Control 4	CSMF[7:0] Colour Subcarrier Manual Frequency Holds the value used to enable the user support odd subcarrier frequencies												
			x	x	x	x	x	x	x	x				

# PRELIMINARY TECHNICAL DATA

## ADV7183

Subaddress	Register	Bit Description	Bit7	Bit6	Bit5	Bit4	Bit3	Bit2	Bit1	Bit0	Comment	Note		
27h	Pixel Delay Control	Reserved												
								0	0	0	Set to Zero			
		CTA[2:0] Chroma Timing Adjust allows a specified timing difference between the Luma and Chroma samples												
				0	0	0						Not valid setting		
				0	0	1						Chroma+2 pixel (early)		
				0	1	0						Chroma+1 pixel (early)		
				0	1	1						No Delay		
				1	0	0						Chroma-1 pixel (late)		
				1	0	1						Chroma-2 pixel (late)		
				1	1	0						Chroma-3 pixel (late)		
				1	1	1						Not valid setting		
		Reserved												
					1								Set to One	
			SWPC This bit allows the Cr and Cb samples to be swapped.											
		0									No swapping			
		1									Swap the Cr and Cb values			
28h	Manual Clock Control 1	CLKVAL[17:16] If enabled via CLKMANE then CLKVAL[17:0] determines the fixed output freq. On the LLC, LLC2 and LLCRef pins.												
									x	x				
		Reserved												
				1	1	1	1					Set to Default		
		CLKMANE Clock Generator Manual Enable allows the analog clock generator to produce a fixed clock frequency which is not dependent on the video signal												
			0									O/p freq set by video		
			1									freq set by CLKVAL[17:0]		
		FIX27E Allows the o/p of fixed 27Mhz crystal clock via LLC, LLC2 and LLCRef o/p pins.												
	0									O/p freq set by clock gen.				
	1									O/p 27Mhz fixed.				
29h	Manual Clock Control 2	CLKVAL[15:8] See above												
			x	x	x	x	x	x	x	x				
2Ah	Manual Clock Control 3	CLKVAL[7:0] See above												
			x	x	x	x	x	x	x	x				

PRELIMINARY TECHNICAL DATA

ADV7183

Subaddress	Register	Bit Description	Bit7	Bit6	Bit5	Bit4	Bit3	Bit2	Bit1	Bit0	Comment	Note		
2Bh	Auto Clock Control	Reserved												
					0	0	0	0	0			Set to Zero		
		ACLKN[2:0] Automatic Clock Generator Mode influences the mode of operation for the LLC										Only when NOT in manual mode		
		0 0 0										Colour Burst line		
		0 0 1										Start:line24 colour burst line		
		0 1 0										Active Video		
		0 1 1										Active Video(<304) PAL	(<264)NTSC	
		1 0 0										Active Video(<304) PAL	(<256)NTSC	
		1 0 1										ActiveVideo(<319/320) PAL	(<273/274)NTSC	
		1 1 0										Invalid		
		1 1 1										Invalid		
2Ch	AGC Mode Control	CAGC[1:0] Chroma Automatic Gain Control selects the basic mode of operation for the AGC in the chroma path.												
								0	0		Manual Fixed gain	Use CMG[11:0]		
								0	1		Use luma gain for chroma			
								1	0		Automatic gain	Based on colour burst		
								1	1		Freeze chroma gain			
		Reserved												
					1	1						Set to One		
		LAGC[2:0] Luma Automatic Gain Control selects the mode of operation for the gain control in the luma path												
		0 0 0										Manual Fixed gain	Use LMG[11:0]	
		0 0 1										AGC no override through white peak. Man IRE control	Blank level to sync tip	
		0 1 0										AGC auto override through white peak. Man IRE control	Blank level to sync tip	
		0 1 1										AGC no override through white peak. Auto IRE control	Blank level to sync tip	
		1 0 0										AGC auto override through white peak. Auto IRE control	Blank level to sync tip	
		1 0 1										AGC active video with white peak		
		1 1 0										AGC active video with average video.		
1 1 1										Freeze gain				
Reserved														
1											Set to One			

# PRELIMINARY TECHNICAL DATA

## ADV7183

Subaddress	Register	Bit Description	Bit7	Bit6	Bit5	Bit4	Bit3	Bit2	Bit1	Bit0	Comment	Note	
2Dh	Chroma Gain Control 1	CMG[11:8] Chroma Manual Gain can be used program a desired manual chroma gain or read back the actual used gain value									CAGC[1:0] settings will decide what mode CMG[11:0] operates in		
		Reserved					x	x	x	x			
	CAGT[1:0] Chroma Automatic Gain Timing allows adjustment of the Chroma AGC tracking speed	Reserved			1	1						Set to One	
		0	0									Slow (TC: 2 sec)	
		0	1									Medium (TC: 1 sec)	
		1	0									Fast (TC: 0.2 sec)	
1	1									Dependent on VID_QUAL			
2Eh	Chroma Gain Control 2	CMG[7:0] Chroma Manual Gain lower 8-bits ,see CMG[11:8] for description											
			x	x	x	x	x	x	x	x			
2Fh	Luma Gain Control 1	LMG[11:8] Luma Manual Gain can be used program a desired manual chroma gain or read back the actual used gain value									LAGC[1:0] settings will decide what mode LMG[11:0] operates in		
		Reserved					x	x	x	x			
	LAGT[1:0]Luma Automatic Gain Timing allows adjustment of the Luma AGC tracking speed	Reserved			1	1						Set to One	
		0	0									Slow (TC: 2 sec)	
		0	1									Medium (TC: 1 sec)	
		1	0									Fast (TC: 0.2 sec)	
1	1									Dependent on VID_QUAL			
30h	Luma Gain Control 2	LMG[7:0] Luma Manual Gain can be used program a desired manual chroma gain or read back the actual used gain value									LAGC[1:0] settings will decide what mode LMG[11:0] operates in		
			x	x	x	x	x	x	x	x			

Subaddress	Register	Bit Description	Bit7	Bit6	Bit5	Bit4	Bit3	Bit2	Bit1	Bit0	Comment	Note	
31h	Manual Gain Shadow Control 1	LMGS[11:8] Luma Manual Gain Store has dual functions, a desired manual luma gain can be programmed or a readback from the register will return the actual gain used.									The function and readback value are dependant on LAGC[2:0] setting.	Gain value will only become active when LAGC[2:0] set to manual fixed gain.	
		Reserved					x	x	x	x			
	SGUE Surveillance Gain Update Enable enables surveillance mode operation see LMGS[11:0] for details	Reserved			1	1	1					Set to One	
		0										Disable LMGS update	
		1										Use LMGS update facility	
32h	Manual Gain Shadow Control 2	LMG[7:0] Chroma Manual Gain lower 8-bits ,see LMG[11:8] for description											
			x	x	x	x	x	x	x	x			

# PRELIMINARY TECHNICAL DATA

# ADV7183

Subaddress	Register	Bit Description	Bit7	Bit6	Bit5	Bit4	Bit3	Bit2	Bit1	Bit0	Comment	Note	
33h	Misc Gain Control	PW_UPD Peak White Update determines the gain based on measurements taken from the active video, this bit determines the rate of gain change.									LAGC[1:0] Must be set to the appropriate mode to enable peak white or average video in the first case		
										0	Update gain once per line		
										1	Update gain once per field		
	AV_AL Average Brightness Active Lines Allows the selection between two ranges of active video to determine the average brightness									0	Lines 33-310		
										1	Lines 33-270		
	Mire[2:0] Max IRE Sets the max. I/p IRE level dependent on the video standard												
					0	0	0					PAL-133 NTSC-122	
					0	0	1					PAL-125 NTSC-115	
					0	1	0					PAL-120 NTSC-110	
					0	1	1					PAL-115 NTSC-105	
					1	0	0					PAL-110 NTSC-100	
					1	0	1					PAL-105 NTSC-100	
					1	1	0					PAL-100 NTSC-100	
					1	1	1					PAL-100 NTSC-100	
	Reserved												
					1							Set to one	
	CKE Colour Kill Enable allows the optional colour kill function to be switched on or off.												
				0								Colour Kill disabled	
				1								Colour Kill enabled	
Reserved													
			1								Set to one		

Subaddress	Register	Bit Description	Bit7	Bit6	Bit5	Bit4	Bit3	Bit2	Bit1	Bit0	Comment	Note
34h	Hsync Position Control 1	Reserved										
							1	1	1	1	Set to One	
	HSE[9:8] HSync End allows the positioning of the HSync output within the video line										HSync ends after HSE[9:0] pixel after falling edge of HSync	
				0	0							
HSB[9:8] HSync begin allows the positioning of HSync output within the video line										HSync starts after HSB[9:0] pixel after the falling edge of HSync		
			0	0								
35h	Hsync Position Control 2	HSB[7:0] See above, using HSB[9:0] and HSE[9:0] the user can program the position and length of HSync output signal										
				0	0	0	0	0	0	0	1	
36h	Hsync Position Control 3	HSE[7:0] See above.										
				0	0	0	0	0	0	0	0	

# PRELIMINARY TECHNICAL DATA

## ADV7183

Subaddress	Register	Bit Description	Bit7	Bit6	Bit5	Bit4	Bit3	Bit2	Bit1	Bit0	Comment	Note		
37h	Polarity	PCLK Sets the polarity of LLC, LLC2 and QCk												
											0	Active High		
												1	Active Low	
		PFF Sets the polarity of HFF, AEF and AFF												
												0	Active High	
												1	Active Low	
		PDV Sets the polarity for Data Field												
												0	Active High	
												1	Active Low	
		PF sets the field sync polarity												
												0	Active High	
												1	Active Low	
		PLLCR sets the LLC Ref Polarity												
												0	Active High	
												1	Active Low	
		PVS sets the Vsync Polarity												
												0	Active High	
												1	Active Low	
		PHVR sets the Href and Vref sync polarities												
												0	Active High	
												1	Active Low	
		PHS sets Hsync Polarity												
												0	Active High	
												1	Active Low	

Subaddress	Register	Bit Description	Bit7	Bit6	Bit5	Bit4	Bit3	Bit2	Bit1	Bit0	Comment	Note		
44h	Resample Control	Reserved Set to Default												
					0	0	0	0	0	1	Set to Default			
		FSC_INV Colour Subcarrier RTCO Inversion allows the inversion of the GL bit												
				x									NB No Default Value	<v85c
				0									Compatible ADV7190/91/94	
			1									Compatible with ADV717x		
		Reserved												
			0								Set to zero			
45h	Reserved	Reserved Functions												
				0	0	1	x	x	0	1	1	Default Value		
				1	0	1	1	1	0	1	1	Set to these values		
F1h	Reserved	Reserved Functions												
				1	1	1	1	0	1	1	x	Default values		
				1	1	1	0	1	1	1	1	Set to these values		
F2h	Reserved	Reserved Functions												
				1	0	0	1	1	1	0	x	Default values		
				1	0	0	0	0	0	0	0	Set to these values		

PRELIMINARY TECHNICAL DATA

**ADV7183**

**POWER ON RESET VALUES**

Register Name	addr (Hex)	Default (Hex)		Register Name	addr (Hex)	Default (Hex)
<b>BASIC BLOCK</b>				<b>ADVANCED BLOCK</b>		
Input Control	00	00		Reserved	1D	xx
Video Selection	01	80		Reserved	1E	xx
Video Enhancement Control	02	04		Reserved	1F	xx
Output Control	03	0C		Reserved	20	xx
Extended Output Control	04	0C		Reserved	21	xx
General Purpose Output	05	40		Reserved	22	xx
Reserved	06	-		Color Subcarrier Control 1	23	Ex
FIFO Control	07	04		Color Subcarrier Control 2	24	xx
Contrast Control	08	80		Color Subcarrier Control 3	25	xx
Saturation Control	09	80		Color Subcarrier Control 4	26	xx
Brightness Control	0A	0		Pixel Delay Control	27	58
Hue Control	0B	0		Manual Clock Control 1	28	xx
Default Value Y	0C	10		Manual Clock Control 2	29	xx
Default Value C	0D	88		Manual Clock Control 3	2A	xx
Temporal Decimation	0E	00		Auto Clock Control	2B	A0
Power Management	0F	00		AGC Mode Control	2C	CE
Status Register	10	-		Chroma Gain Control 1	2D	Fx
Info Register	11	-		Chroma Gain Control 2	2E	xx
				Luma Gain Control 1	2F	Fx
<b>ADVANCED BLOCK</b>				Luma Gain Control 2	30	xx
Reserved	12	-		Manual Gain Shadow Control 1	31	7x
Analog Control (internal)	13	45		Manual Gain Shadow Control 2	32	xx
Analog Clamp Control	14	18		Misc Gain Control	33	E3
Digital Clamp Control 1	15	6x		Hsync Position Control 1	34	0F
Digital Clamp Control 2	16	xx		Hsync Position Control 2	35	01
Shaping Filter Control	17	01		Hsync Position Control 3	36	00
Reserved	18	-		Polarity Control	37	00
Comb Filter Control	19	10		Reserved	44	x1
Reserved	1A	xx		Reserved	45	xx
Reserved	1B	xx		Reserved	F1	Fx
Reserved	1C	xx		Reserved	F2	9x

# ADV7183

## APPENDIX 1

### BOARD DESIGN AND LAYOUT CONSIDERATIONS

The ADV7183 is a highly integrated circuit containing both precision analog and high speed digital circuitry. It has been designed to minimize interference effects on the integrity of the analog circuitry by the high speed digital circuitry. It is imperative that these same design and layout techniques be applied to the system level design such that high speed, accurate performance is achieved. The "Recommended Analog Circuit Layout" shows the analog interface between the device and monitor.

The layout should be optimized for lowest noise on the ADV7183 power and ground lines by shielding the digital inputs and providing good decoupling. The lead length between groups of VDD and GND pins should be minimized so as to minimize inductive ringing.

#### Ground Planes

The ground plane should encompass all ADV7183 ground pins, voltage reference circuitry, power supply bypass circuitry for the ADV7183, the analog output/input traces, and all the digital signal traces leading up to the ADV7183. The ground plane is the board's common ground plane.

#### Power Planes

The ADV7183 and any associated analog circuitry should have its own power plane, referred to as the analog power plane (VDD). This power plane should be connected to the regular PCB power plane ( $V_{CC}$ ) at a single point through a ferrite bead. This bead should be located within three inches of the ADV7183.

The PCB power plane should provide power to all digital logic on the PC board, and the analog power plane should provide power to all ADV7183 power pins and voltage reference circuitry.

Plane-to-plane noise coupling can be reduced by ensuring that portions of the regular PCB power and ground planes do not overlay portions of the analog power plane, unless they can be arranged such that the plane-to-plane noise is common mode.

#### Supply Decoupling

For optimum performance, bypass capacitors should be installed using the shortest leads possible, consistent with reliable operation, to reduce the lead inductance. Best performance is obtained with 0.1  $\mu$ F ceramic capacitor decoupling. Each group of VDD pins on the ADV7183 must have at least one 0.1  $\mu$ F decoupling capacitor to GND. These capacitors should be placed as close as possible to the device.

It is important to note that while the ADV7183 contains circuitry to reject power supply noise, this rejection decreases with frequency. If a high frequency switching power supply is used, the designer should pay close attention to reducing power supply noise and consider using a three terminal voltage regulator for supplying power to the analog power plane.

#### Digital Signal Interconnect

The digital inputs to the ADV7183 should be isolated as much as possible from the analog inputs and other analog circuitry. Also, these input signals should not overlay the analog power plane.

Due to the high clock rates involved, long clock lines to the ADV7183 should be avoided to reduce noise pickup. Any active termination resistors for the digital inputs should be connected to the regular PCB power plane ( $V_{CC}$ ), and not the analog power plane.

#### Analog Signal Interconnect

The ADV7183 should be located as close as possible to the input connectors to minimize noise pickup and reflections due to impedance mismatch.

The video input signals should overlay the ground plane, and not the analog power plane, to maximize the high frequency power supply rejection.

Digital Outputs, especially Pixel Data Inputs and clocking signals should never overlay any of the analog signal circuitry and should be kept as far away as possible.

The ADV7183 should have no inputs left floating. Any inputs that are not required should be tied to ground.



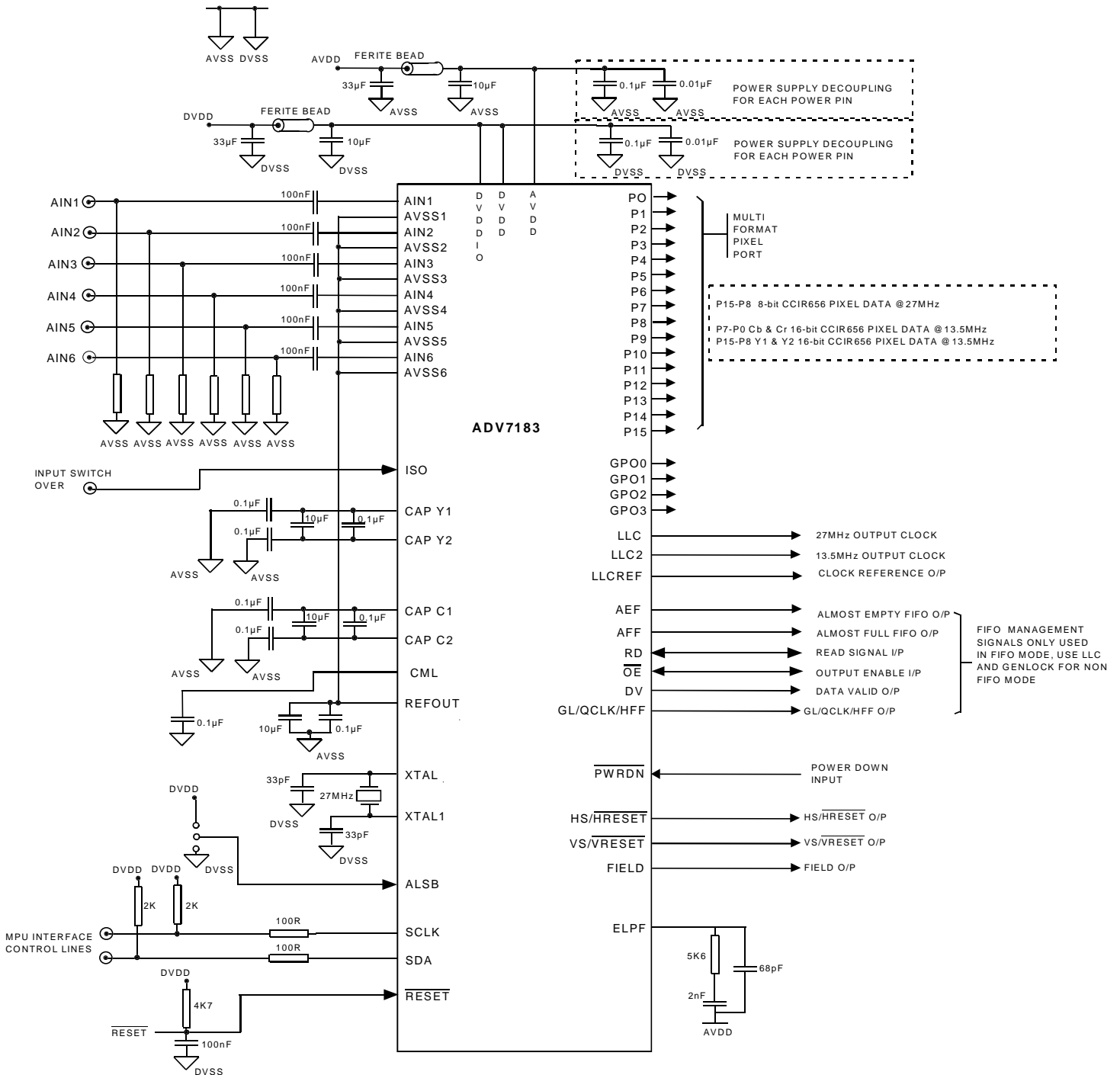

Figure 1. Recommended Circuit Layout

# ADV7183

## OUTLINE DIMENSIONS

Dimensions shown in inches and (mm).

### 80-Lead LQFP (ST-80)

