

### FEATURES

- 2.3 V to 5.5 V input voltage range**
- Output voltage levels ( $V_{DDA}$  and  $V_{DDB}$  to  $V_{SS} \leq 35$  V)**
  - Low output voltage levels: down to  $-24.4$  V
  - High output voltage levels: up to  $+35$  V
- Rise/fall time: 12 ns/19.5 ns typical**
- Propagation delay: 80 ns typical**
- Operating frequency: 100 kHz typical**
- Ultralow quiescent current: 65  $\mu$ A typical**
- 20-lead, Pb-free, TSSOP package**

### APPLICATIONS

- Low voltage to high voltage translation
- TFT-LCD panels
- Piezoelectric motor drivers

### GENERAL DESCRIPTION

The ADG3123 is an 8-channel, noninverting CMOS to high voltage level translator. Fabricated on an enhanced LC<sup>2</sup>MOS process, the device is capable of operating at high supply voltages while maintaining ultralow power consumption.

The internal architecture of the device ensures compatibility with logic circuits running from supply voltages within the 2.3 V to 5.5 V range. The voltages applied to Pin  $V_{DDA}$ , Pin  $V_{DDB}$ , and Pin  $V_{SS}$  set the logic levels available at the outputs on the Y side of the device. Pin  $V_{DDA}$  and Pin  $V_{DDB}$  set the high output level for Pin Y1 to Pin Y6 and for Pin Y7 to Pin Y8, respectively. The  $V_{SS}$  pin sets the low output level for all channels. The ADG3123 can provide output voltage levels down to  $-10$  V for a low input level and up to  $+30$  V for a high input logic level. For proper operation,  $V_{DDB}$  must always be greater than or equal to  $V_{DDA}$  and the voltage between the Pin  $V_{DDB}$  and Pin  $V_{SS}$  should not exceed 35 V.

The low output impedance of the channels guarantees fast rise and fall times even for significant capacitive loads. This feature, combined with low propagation delay and low power consumption, makes the ADG3123 an ideal driver for TFT-LCD panel applications.

### FUNCTIONAL BLOCK DIAGRAM

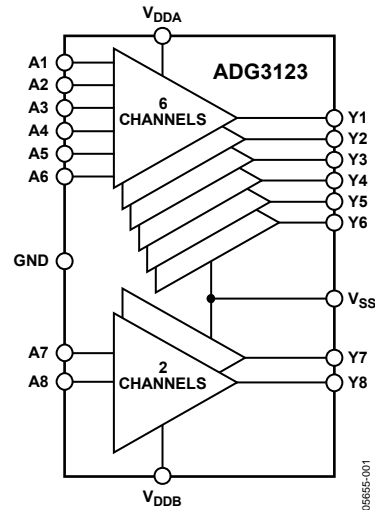

Figure 1.

The ADG3123 is guaranteed to operate over the  $-40^{\circ}\text{C}$  to  $+85^{\circ}\text{C}$  temperature range and is available in a compact, 20-lead TSSOP, Pb-free package.

### PRODUCT HIGHLIGHTS

1. Compatible with a wide range of CMOS logic levels.
2. High output voltage levels.
3. Fast rise and fall times coupled with low propagation delay.
4. Ultralow power consumption.
5. Compact, 20-lead TSSOP, Pb-free package.

#### Rev. A

Information furnished by Analog Devices is believed to be accurate and reliable. However, no responsibility is assumed by Analog Devices for its use, nor for any infringements of patents or other rights of third parties that may result from its use. Specifications subject to change without notice. No license is granted by implication or otherwise under any patent or patent rights of Analog Devices. Trademarks and registered trademarks are the property of their respective owners.

**TABLE OF CONTENTS**

Features .....	1	Typical Performance Characteristics .....	6
Applications.....	1	Terminology .....	9
Functional Block Diagram .....	1	Theory of Operation .....	10
General Description .....	1	Input Driving Requirements.....	10
Product Highlights .....	1	Output Load Requirements .....	10
Revision History .....	2	Power Supplies.....	10
Specifications.....	3	Applications.....	11
Absolute Maximum Ratings.....	4	Outline Dimensions .....	12
ESD Caution.....	4	Ordering Guide .....	12
Pin Configuration and Function Descriptions.....	5		

**REVISION HISTORY**

**5/06—Rev. 0 to Rev. A**

Changes to Features, General Description, and Product Highlights .....	1
Changes to Specifications .....	3
Changes to Figure 4 through Figure 9 .....	6
Changes to Figure 14 and Figure 15.....	7
Changes to Theory of Operations section and Power Supplies section.....	10

**9/05—Revision 0: Initial Version**

# SPECIFICATIONS

$V_{DDA} = V_{DDB} = 27\text{ V}$ ,  $V_{SS} = -7\text{ V}$ ,  $\text{GND} = 0\text{ V}$ , unless otherwise noted.<sup>1</sup>

Table 1.

Parameter	Symbol	Min	Typ <sup>2</sup>	Max	Unit	Conditions
<b>DIGITAL INPUTS (Pin A1 to Pin A8)</b>						
Input High Voltage	$V_{IH}$	1.7			V	$V_{AX} = 0\text{ V to } 5.5\text{ V}$
Input Low Voltage	$V_{IL}$			0.8	V	
Leakage Current	$I_{IL}$		$\pm 0.03$	$\pm 1$	$\mu\text{A}$	
Capacitance <sup>3</sup>	$C_i$		1		pF	
<b>ANALOG INPUTS (Pin <math>V_{DDA}</math>)</b>						
Input Voltage Range	$V_{DDA}$	0		$V_{DDB}$	V	
<b>DIGITAL OUTPUTS (Pin Y1 to Pin Y8)</b>						
Output High Voltage (Pin Y1 to Pin Y6)	$V_{OH}$	$V_{DDA} - 1$			V	$V_{DDA} = V_{DDB} = 25\text{ V to } 30\text{ V}$ , $V_{SS} = -5\text{ V to } -7\text{ V}$ , $V_{DDA}$ and $V_{DDB}$ to $V_{SS} \leq 35\text{ V}$
Output High Voltage (Pin Y7 to Pin Y8)	$V_{OH}$	$V_{DDB} - 1$			V	
Output Low Voltage	$V_{OL}$			$V_{SS} + 1$	V	$I_{OH} = -10\text{ mA}$ $I_{OL} = +10\text{ mA}$
Output Impedance	$R_o$		30		$\Omega$	$V_{DDA} = V_{DDB} = +27\text{ V}$ , $V_{SS} = -7\text{ V}$
<b>SWITCHING CHARACTERISTICS<sup>3</sup></b>						
Propagation Delay						
Low to High Transition	$t_{PLH}$		76	125	ns	See Figure 2
High to Low Transition	$t_{PHL}$		80	125	ns	
Rise Time	$t_R$		12	20	ns	
Fall Time	$t_F$		19.5	32	ns	
Maximum Operating Frequency	$F_o$	50	100		kHz	
100 pF load, all channels, see Figure 2						
<b>POWER REQUIREMENTS</b>						
Quiescent Power Supply Current						
	$I_{DDA}$		0.03	1	$\mu\text{A}$	$V_{AX} = 0\text{ V or } 5.5\text{ V}$ , no load, $V_{DDA} \leq V_{DDB}$
	$I_{DDB}$		65	150	$\mu\text{A}$	
	$I_{SS}$		0.03	1	$\mu\text{A}$	
Power Supply Voltages						
$V_{DDB}$ to $V_{SS}$		10.8		35	V	$V_{DDB}$ to $V_{SS} \leq 35\text{ V}$
$V_{DDB}$ to GND	$V_{DDB}$	10.8		35	V	
$V_{SS}$ to GND	$V_{SS}$	-24.2		0	V	

<sup>1</sup> Temperature range for B version is  $-40^\circ\text{C}$  to  $+85^\circ\text{C}$ .

<sup>2</sup> Typical values are specified at  $25^\circ\text{C}$ .

<sup>3</sup> Guaranteed by design; not subject to production testing.

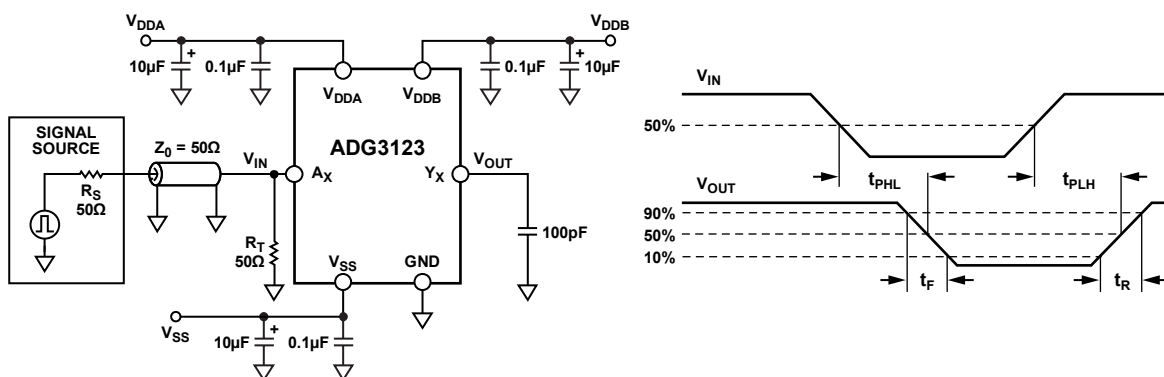

Figure 2. Switching Characteristics Test Circuit

## ABSOLUTE MAXIMUM RATINGS

T<sub>A</sub> = 25°C, unless otherwise noted.

**Table 2.**

Parameter	Rating
V <sub>DDA</sub> /V <sub>DDDB</sub> to V <sub>SS</sub>	44 V
V <sub>DDDB</sub> to GND	−0.3 V to +32 V
V <sub>DDA</sub> to GND	−0.3 V to V <sub>DDDB</sub>
V <sub>SS</sub> to GND	+0.3 V to −32 V
Digital Inputs <sup>1</sup>	V <sub>SS</sub> − 0.3 V to V <sub>DDDB</sub> + 0.3 V or 20 mA, whichever occurs first
Load Current Per Device	
Average	15 mA at 25°C 8 mA at 85°C
Peak Current <sup>2</sup>	150 mA at 25°C 80 mA at 85°C
Operating Temperature Range	
Industrial (B Version)	−40°C to +85°C
Storage Temperature Range	−65°C to +125°C
Junction Temperature	150°C
Thermal Impedance, θ <sub>JA</sub>	78°C/W <sup>3</sup>
Reflow Soldering (Pb-Free)	
Peak Temperature	260 (+0/−5)°C
Time at Peak Temperature	10 seconds to 40 seconds

<sup>1</sup> Overvoltage at Pin A1 to Pin A8 is clamped by internal diodes. Limit the current to the maximum ratings given.

<sup>2</sup> Pulsed at 100 kHz; 10% duty cycle maximum with the load shown in Figure 2.

<sup>3</sup> Guaranteed when the device is soldered on a 4-layer board.

Stresses above those listed under Absolute Maximum Ratings may cause permanent damage to the device. This is a stress rating only; functional operation of the device at these or any other conditions above those indicated in the operational section of this specification is not implied. Exposure to absolute maximum rating conditions for extended periods may affect device reliability.

Only one absolute maximum rating can be applied at any one time.

## ESD CAUTION

ESD (electrostatic discharge) sensitive device. Electrostatic charges as high as 4000 V readily accumulate on the human body and test equipment and can discharge without detection. Although this product features proprietary ESD protection circuitry, permanent damage may occur on devices subjected to high energy electrostatic discharges. Therefore, proper ESD precautions are recommended to avoid performance degradation or loss of functionality.



## PIN CONFIGURATION AND FUNCTION DESCRIPTIONS

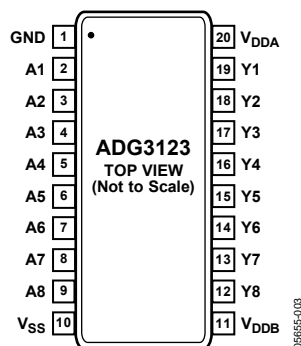

Figure 3. Pin Configuration

Table 3. Pin Function Descriptions

Pin No.	Mnemonic	Description
1	GND	Ground Reference (0 V).
2 to 9	A1 to A8	Level Translator CMOS Inputs.
10	V <sub>SS</sub>	Most Negative Power Supply. Use the V <sub>SS</sub> pin to generate the output low level for Output Y1 to Output Y8.
11	V <sub>DDB</sub>	Positive Power Supply. Use the V <sub>DDB</sub> pin to generate the output high level for Output Y7 and Output Y8.
12 to 19	Y8 to Y1	Level Translator High Voltage Outputs.
20	V <sub>DDA</sub>	Analog Input. Use the V <sub>DDA</sub> pin to generate the output high level for Output Y1 to Output Y6 ( $V_{DDA} \leq V_{DDB}$ ).

## TYPICAL PERFORMANCE CHARACTERISTICS

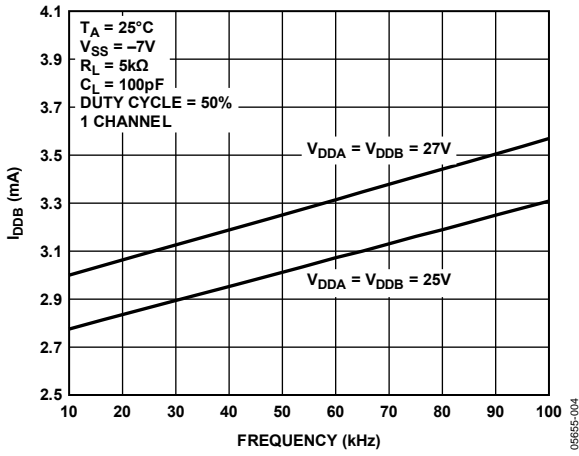

Figure 4. Supply Current ( $I_{DDB}$ ) vs. Frequency

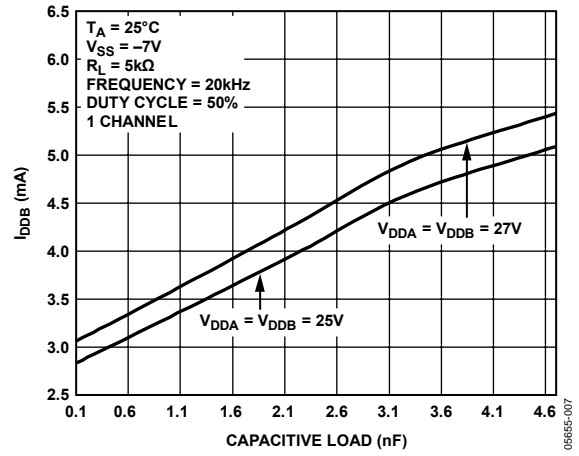

Figure 7. Supply Current ( $I_{DDB}$ ) vs. Capacitive Load

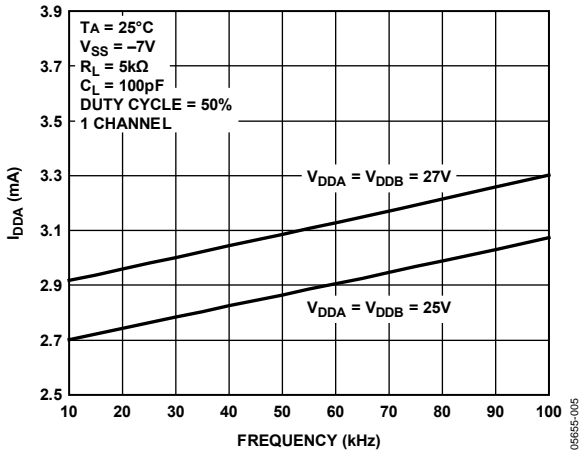

Figure 5. Supply Current ( $I_{DDA}$ ) vs. Frequency

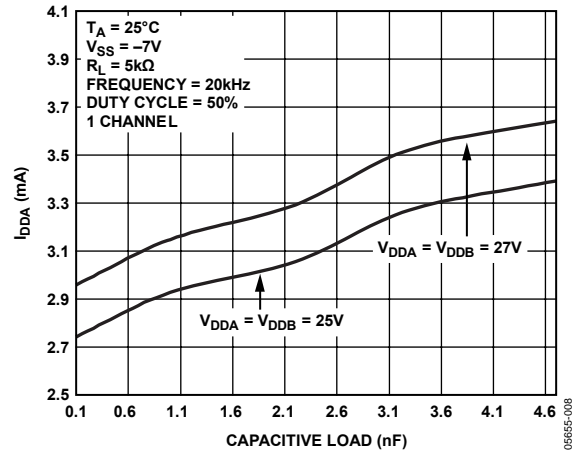

Figure 8. Supply Current ( $I_{DDA}$ ) vs. Capacitive Load

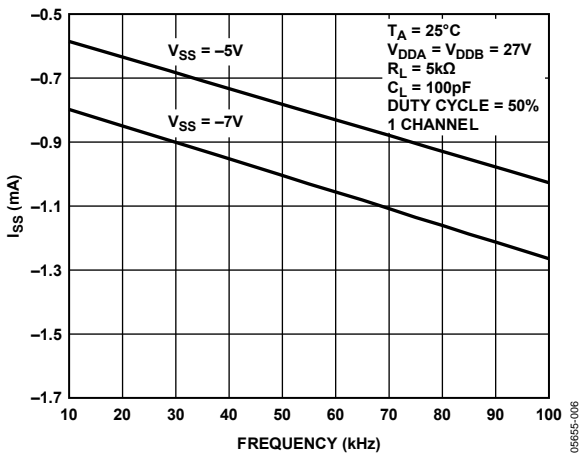

Figure 6. Supply Current ( $I_{SS}$ ) vs. Frequency

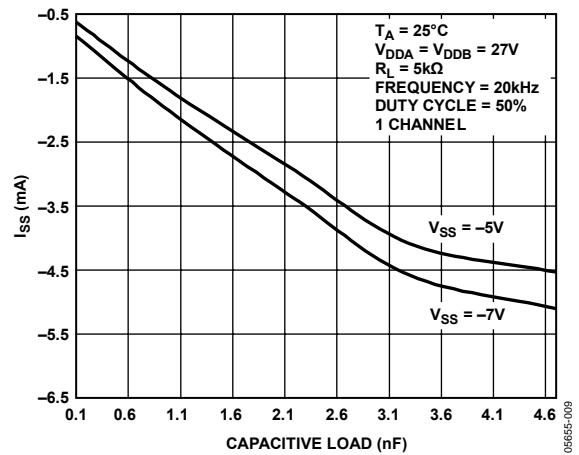

Figure 9. Supply Current ( $I_{SS}$ ) vs. Capacitive Load

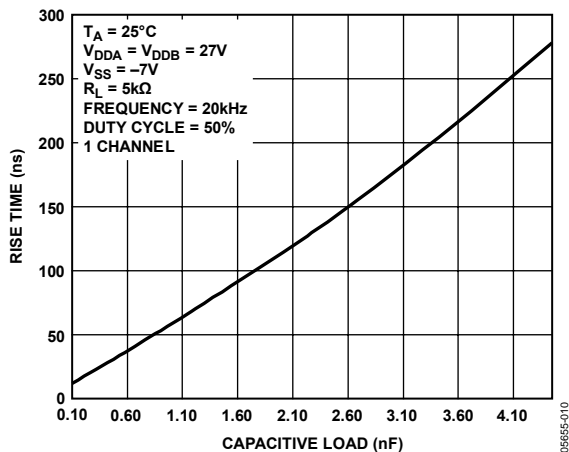

Figure 10. Rise Time vs. Capacitive Load

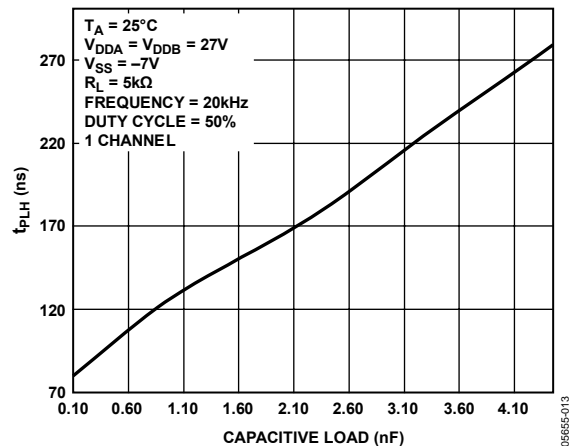

Figure 13. Propagation Delay ( $t_{PLH}$ ) vs. Capacitive Load

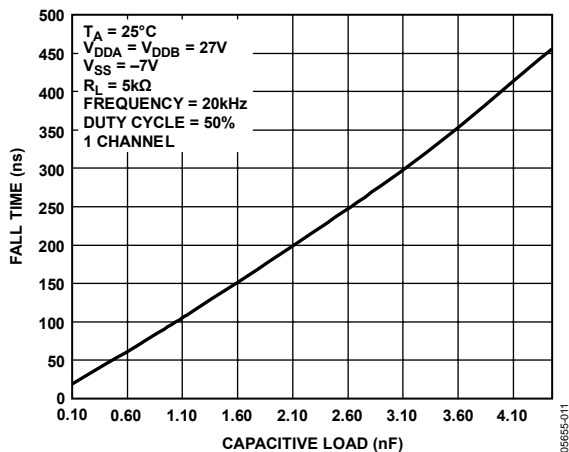

Figure 11. Fall Time vs. Capacitive Load

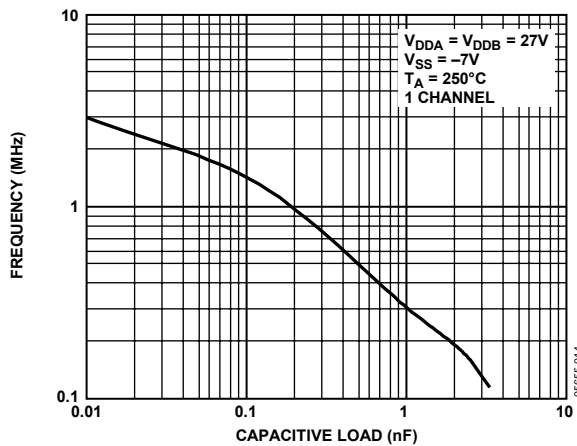

Figure 14. Maximum Operating Frequency vs. Capacitive Load (One Channel)

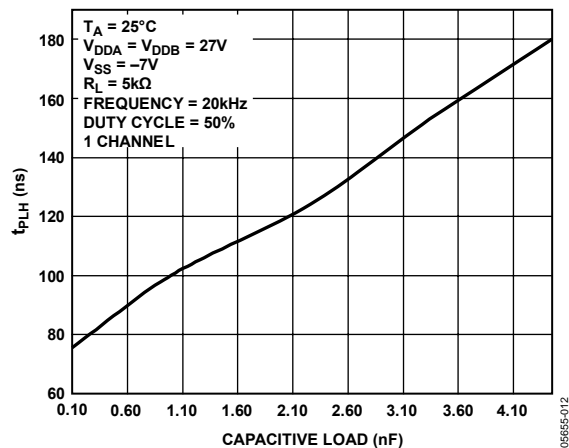

Figure 12. Propagation Delay ( $t_{PLH}$ ) vs. Capacitive Load

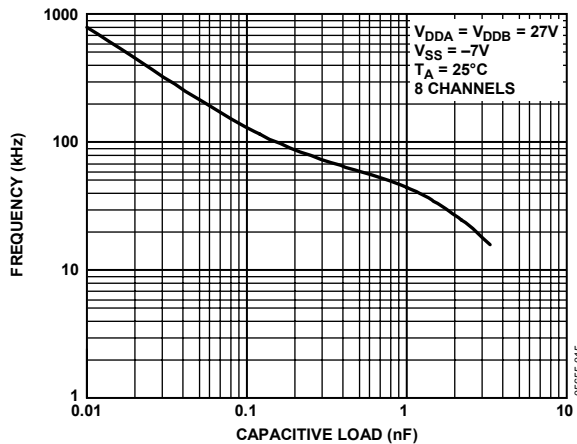

Figure 15. Maximum Operating Frequency vs. Capacitive Load (Eight Channels)

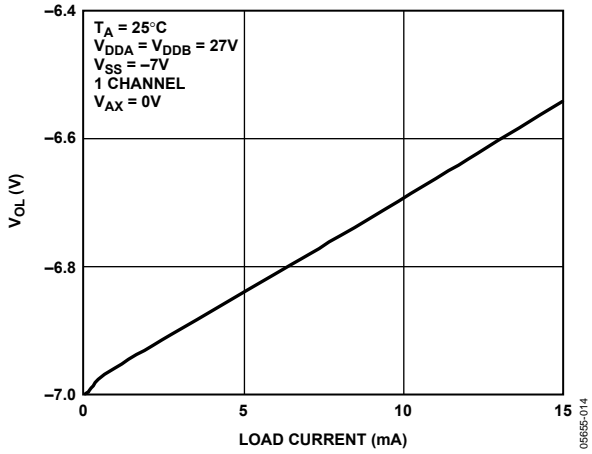

Figure 16. Output Voltage ( $V_{OL}$ ) vs. Load Current

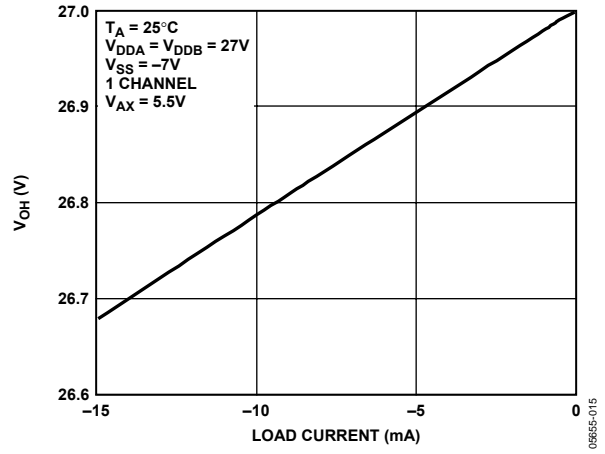

Figure 17. Output Voltage ( $V_{OH}$ ) vs. Load Current



## TERMINOLOGY

**V<sub>IH</sub>**

Logic input high voltage at Pin A1 to Pin A8.

**V<sub>IL</sub>**

Logic input low voltage at Pin A1 to Pin A8.

**I<sub>IL</sub>**

Leakage current at Pin A1 to Pin A8.

**C<sub>I</sub>**

Capacitance measured at Pin A1 to Pin A8.

**V<sub>OH</sub>**

Logic output high voltage at Pin Y1 to Pin Y8.

**V<sub>OL</sub>**

Logic output low voltage at Pin Y1 to Pin Y8.

**R<sub>o</sub>**

Output impedance.

**t<sub>PLH</sub>**

Propagation delay through the part measured between the input signal applied to any one channel and its corresponding output for a low-to-high transition (see Figure 2).

**t<sub>PHL</sub>**

Propagation delay through the part measured between the input signal applied to any one channel and its corresponding output for a high-to-low transition (see Figure 2).

**t<sub>r</sub>**

Rise time of the output signal at Pin Y1 to Pin Y8 (see Figure 2).

**t<sub>f</sub>**

Fall time of the output signal at the Pin Y1 to Pin Y8 (see Figure 2).

**F<sub>o</sub>**

Frequency of the signal applied to the A1 to A8 input pins.

**V<sub>DDA</sub>**

Input voltage used to generate the high logic levels for Y1 to Y6 outputs.

**V<sub>DDB</sub>**

Positive power supply voltage. Also used to generate the high logic levels for Y7 to Y8 outputs.

**V<sub>SS</sub>**

Negative power supply voltage. It is used to generate the low logic level for Y1 to Y8 outputs.

**GND**

Ground (0 V) reference.

**I<sub>DDA</sub>**

Supply current at the V<sub>DDA</sub> pin.

**I<sub>DDB</sub>**

Supply current at the V<sub>DDB</sub> pin.

**I<sub>SS</sub>**

Supply current at the V<sub>SS</sub> pin.

## THEORY OF OPERATION

The ADG3123 is an 8-channel, noninverting CMOS to high voltage level translator. Fabricated on an enhanced LC<sup>2</sup>MOS process, the device is capable of operating at high supply voltages while maintaining ultralow power consumption.

The device requires a dual-supply voltage,  $V_{DDB}$  and  $V_{SS}$ , which sets the low logic levels for all outputs and the high logic levels for the Y7 and Y8 outputs. The  $V_{DDA}$  pin acts as an analog input. The voltage applied to the  $V_{DDA}$  pin sets the output high logic level for the Y1 to Y6 outputs.

The device translates the CMOS logic levels applied to the A1 to A8 inputs into high voltage bipolar levels available on the Y side of the device at Pin Y1 to Pin Y8.

To ensure proper operation,  $V_{DDB}$  must always be greater than or equal to  $V_{DDA}$  and the voltage between the Pin  $V_{DDB}$  and Pin  $V_{SS}$  should not exceed 35 V.

### INPUT DRIVING REQUIREMENTS

The ADG3123 design ensures low input capacitance and leakage current thereby reducing the loading of the circuit that drives the input pins (Pin A1 to Pin A8) to a minimum. Its input threshold levels are compliant with JEDEC standards for drivers operated from supply voltages between 2.3 V and 5.5 V. It is recommended that the inputs of any unused channel be tied to a stable logic level (low or high).

### OUTPUT LOAD REQUIREMENTS

The low output impedance of the ADG3123 allows each channel to drive both resistive and capacitive loads. The maximum load current is limited by the current carrying capability of any given channel. If more channels are used, the maximum load current per channel is reduced accordingly. Note that the sum of the load currents on all channels should never exceed the absolute maximum ratings specifications.

The average load current on each channel,  $I_{CHANNEL}$ , can be determined using the formulas shown in the Capacitive Loads and the Resistive Loads sections.

### Capacitive Loads

$$I_{CHANNEL}(A) = F_O \times C_L \times (V_{DDX} + |V_{SS}|)$$

where:

$F_O$  is the frequency of the signal applied to the channel in Hz.

$C_L$  is the load capacitance in farads.

$V_{SS}$  is the voltage applied to the  $V_{SS}$  pin.

$V_{DDX}$  is  $V_{DDA}$  for Y1 to Y6 outputs, and  $V_{DDB}$  for Y7 to Y8 outputs.

### Resistive Loads

$$I_{CHANNEL}(A) = \frac{D \times V_{DDX} + (1 - D) \times |V_{SS}|}{R_L}$$

where:

$D$  is the duty cycle of the input signal.  $D$  is defined as the ratio between the high state duration of the signal and its period.

$R_L$  is the load resistor in  $\Omega$ .

$V_{SS}$  is the voltage applied to the  $V_{SS}$  pin.

$V_{DDX}$  is  $V_{DDA}$  for Y1 to Y6 outputs, and  $V_{DDB}$  for Y7 to Y8 outputs.

### POWER SUPPLIES

The ADG3123 operates from a dual-supply voltage. As good design practice for all CMOS devices dictates, power up the ADG3123 first ( $V_{DDB}$  and  $V_{SS}$ ) before applying the signals to its inputs (A1 to A8 and  $V_{DDA}$ ). To ensure correct operation of the ADG3123, the voltage applied to the  $V_{DDB}$  pin must always be greater than or equal to  $V_{DDA}$  and the voltage between the Pin  $V_{DDB}$  and Pin  $V_{SS}$  should not exceed 35 V.

To ensure optimum performance, use decoupling capacitors on all power supply pins. Furthermore, good engineering and layout practice suggests placing these capacitors as close as possible to the package supply pins.

## APPLICATIONS

The high voltage operation coupled with high current driving capability and the wide range of CMOS levels accepted by the ADG3123, make the device ideal for LCD-TFT panel applications. In this type of application, the controllers that generate the timing signals required to control the pixel scanning process inside the panel are usually low voltage CMOS devices.

Most LCD-TFT panels operate at high supply voltages; therefore, the timing signals generated by the controller require level translation to drive the panel. Figure 18 shows a typical application circuit where the ADG3123 translates eight timing signals provided by the timing controller into high voltage logic levels required to drive the panel.

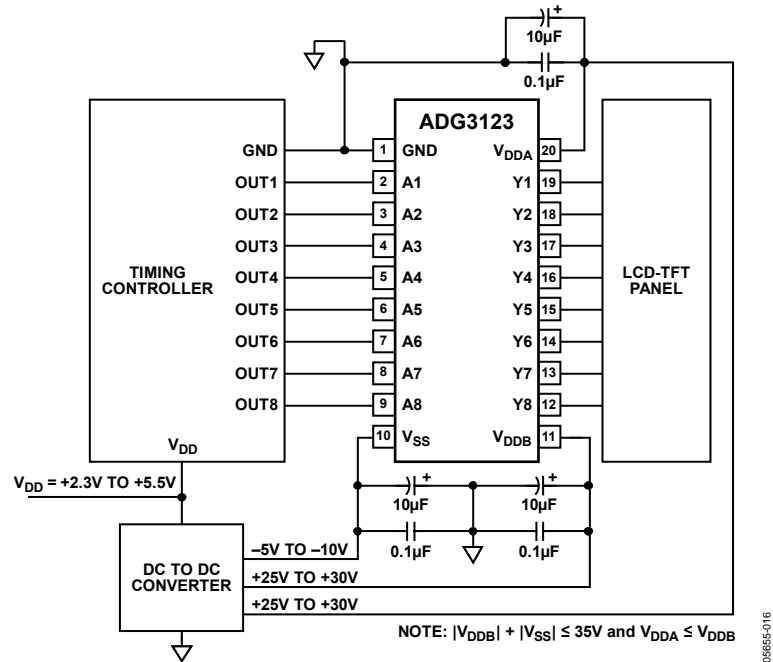
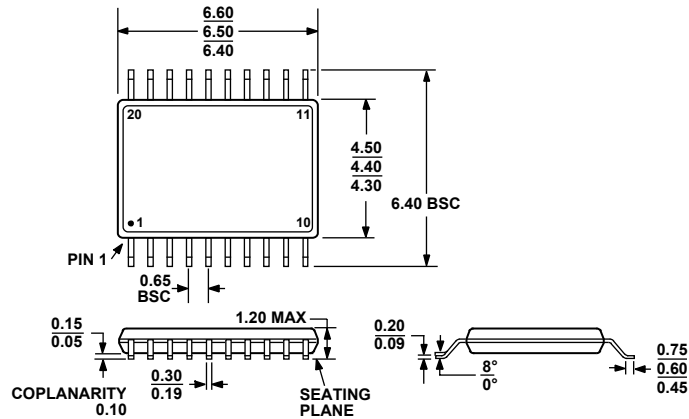

Figure 18. Typical Application Circuit

06655-016

## OUTLINE DIMENSIONS



COMPLIANT TO JEDEC STANDARDS MO-153-AC

Figure 19. 20-Lead Thin Shrink Small Outline Package [TSSOP]  
(RU-20)

Dimensions shown in millimeters

## ORDERING GUIDE

Model	Temperature Range	Package Description	Package Option
ADG3123BRUZ <sup>1</sup>	-40°C to +85°C	20-Lead Thin Shrink Small Outline Package (TSSOP)	RU-20
ADG3123BRUZ-REEL <sup>1</sup>	-40°C to +85°C	20-Lead Thin Shrink Small Outline Package (TSSOP)	RU-20
ADG3123BRUZ-REEL7 <sup>1</sup>	-40°C to +85°C	20-Lead Thin Shrink Small Outline Package (TSSOP)	RU-20

<sup>1</sup> Z = Pb-free part.